

Amendments to the 2002 Water System Standards

Description	WSS Section Modified	Approval Date
Chlorination of Pipelines	Division 300, Section 302, Sub-section 302.29 Chlorination of Water Pipeline	9/1/22
Pipe Cushion	Division 200, Section 209, Sub-section 209.02 Pipe Cushion	8/22/22
Deadline to Comply with All Amendments	None	2/9/22
Controlled Low Strength Material (CLSM)	Division 200, Section 209, Sub-section 209.06 Controlled Low Strength Materials (CLSM) and Division 300, Section 302, Sub-section 302.03 Trench Backfill	11/8/21
Off-Site Fire Protection	Division 100, Section 111, Sub-section 111.03 Fire Flows, Duration and Hydrant Spacing	7/30/21
Turbine Meter Splice Length	Division 400, Section 403 Standard Details	3/25/21
Approved Material <i>J&S Valve, Inc.</i>	Division 400, Section 402 Sub-Section II Valves and Appurtenances	2/26/21
Chlorination of Pipelines	Division 300, Section 302, Sub-section 302.29 Chlorination of Water Pipeline	12/16/20
Bonded Dielectric Coating	Division 500, Water System External Corrosion Control Standards, Volume 3, dated 1991	10/5/20
Type and Classes of Mains, and Pipe Cushion	Division 100, Section 102, Sub-section 102.05 Type, Class and Division 200, Section 209, Sub-section 209.02 Pipe Cushion	7/29/19
Expanded Metal Fencing	Division 100, Section 105, Sub-section 105.08 Perimeter Fence and Division 300, Section 303, Sub-section 303.34 Expanded Metal Fence and Gate	8/2/18
Polyethylene Encasement and Exterior Coating	Division 200, Section 202 - Ductile Iron Pipe, Fittings, and Appurtenances	11/17/16
Approved Material <i>The Ford Meter Box Company, Inc.</i>	Division 400, Section 402, Sub-section III Service Laterals, Fittings and Appurtenances	5/6/16
Trench Backfill	Division 400, Section 403 Standard Details	4/29/16
Ductile Iron Pipe	Division 200, Section 202 - Ductile Iron Pipe, Fittings, and Appurtenances	4/15/16

Description	WSS Section Modified	Approval Date
Approved Material <i>DFW Plastics, Inc.</i>	Division 400, Section 402, Sub-section III Service Laterals, Fittings and Appurtenances	5/13/15
Plastic Pipe	Division 200, Section 204 Plastic Pipe; Division 300, Section 302 Water Mains and Appurtenances, Sub-sections 302.14 Plastic Pipe & 302.15 Fittings and Specials	4/23/15
Water Main Clearances	Division 100, Section 102 Mains, Sub-section 102.01 Location	4/23/15
3/4" Meter Splice Length	Division 400, Section 403 Standard Details	12/8/14
Approved Material <i>Christy's</i>	Division 400, Section 402 Sub-section I Pipes and Appurtenances	9/19/14
Approved Material <i>Clow Valve Company</i>	Division 400, Section 402, Sub-section IV Fire Hydrants	6/20/14
Brass Products - Lead Free	Division 200, Section 211 Brass Products & Division 400, Section 402, Sub-section III Service Laterals, Fittings and Appurtenances	10/22/13
Approved Material <i>Jensen Precast</i>	Division 400, Section 402, Sub-section III Service Laterals, Fittings and Appurtenances	1/4/13
Rescinding Approval for Polyethylene (PE) Pipe	Division 200, Section 208 - Service Laterals and Appurtenances, 208.03 Plastic Tubing	12/14/12
Brass Products	Division 200, Section 211 Brass Products & Division 400, Section 402, Sub-section III Service Laterals, Fittings and Appurtenances	6/5/12
Approved Material <i>Aarmorcast</i>	Division 400, Section 402, Sub-section III Service Laterals, Fittings and Appurtenances	5/14/12
Approved Material <i>Romac</i>	Division 400, Section 402 Sub-section I Pipes and Appurtenances	11/9/11
Approved Material <i>IPEX</i>	Division 400, Section 402 Sub-section I Pipes and Appurtenances	9/14/11
Rescinding Approval for Concrete Cylinder Pipe	Division 200, Section 203 Concrete Cylinder Pipe and Fittings	7/15/11
Rescinding Approved Material <i>Royal Pipe Systems</i>	Division 400, Section 402 Sub-section I Pipes and Appurtenances	4/29/11
Approved Material <i>METCO</i>	Division 400, Section 402 Sub-section I Pipes and Appurtenances	11/4/10
Approved Material <i>Advance Products and Systems</i>	Division 400, Section 402 Sub-section I Pipes and Appurtenances	5/6/10
Approved Material <i>Garlock</i>	Division 400, Section 402 Sub-section I Pipes and Appurtenances	1/19/10

Description	WSS Section Modified	Approval Date
Approved Material <i>North American Pipe Corporation</i>	Division 400, Section 402 Sub-section I Pipes and Appurtenances	11/10/09
Approved Material <i>Multi Fittings</i>	Division 400, Section 402 Sub-section I Pipes and Appurtenances	10/27/09
Approved Material <i>Diamond Plastics</i>	Division 400, Section 402 Sub-section I Pipes and Appurtenances	8/14/09
FM Meter & Box Standard Details	Division 400, Section 403 Standard Details	5/18/09
Approved Material <i>Polytubes</i>	Division 400, Section 402, Subsection III Service Laterals, Fittings and Appurtenances	2/24/09
Minimum Utility Depth	Division 100, Section 102 Mains, Sub-section 102.03 Cover & Division 400, Section 403 Standard Details	12/31/08
Approved Material <i>American R/D</i>	Division 400, Section 402 Sub-Section II Valves and Appurtenances	12/18/08
Approved Material <i>Armorcast</i>	Division 400, Section 402, Sub-section III Service Laterals, Fittings and Appurtenances	12/4/2008, amended 6/26/2015
Distance between main valves	Division 100, Section 103 Sub-section 103.01 Location, Type, Working Pressure	10/21/08
Nuts and bolts for flanged joints and fire hydrant break-off bolts	Division 200, Section 202.04 Flanged Joint and Section 206.1 General	3/18/08
Approved Material <i>Sigma Corporation</i>	Division 400, Section 402 Sub-section I Pipes and Appurtenances	10/31/07
Approved Material <i>Star Pipe Products, Inc.</i>	Division 400, Section 402 Sub-section I Pipes and Appurtenances	5/4/07
Electronic Markers	New requirement	8/25/06
Approved Material <i>Pratt & Lambert</i>	Division 400, Section 402 Sub-section V Paints and Coatings	1/27/04
Cathodic Protection	See 2021 Update of the Water System External Corrosion Control Standards Division 500, Section 1.2 (Part 2), Table 3	10/15/03
Approved Material <i>Tripac Fasteners & NSS Industries</i>	Division 400, Section 402 Sub-section I Pipes and Appurtenances	8/12/03
Nuts and bolts for mechanical joints	Division 200, Section 202.02 Mechanical Joint	7/22/03

Description	WSS Section Modified	Approval Date
Approved Material <i>Romac</i>	Division 400, Section 402 Sub-section I Pipes and Appurtenances	6/20/03
Approved Material <i>Sherwin Williams</i>	Division 400, Section 402 Sub-section V Paints and Coatings	5/23/03
Rescinded 4/29/2011 Approved Material <i>Royal Pipe Systems</i>	Division 400, Section 402 Sub-Section I Pipes and Appurtenances	5/19/03
Approved Material <i>FSC Coatings</i>	Division 400, Section 402 Sub-section V Paints and Coatings	5/12/03
Dis-approved Material <i>Powerseal</i>	Division 400, Section 402 Sub-section I Pipes and Appurtenances	3/24/03
Approved Material <i>James Jones</i>	Division 400, Section 402 Sub-section III Service Laterals, Fittings and Appurtenances	11/27/02
Approved Materials for Globe Valves	Division 400, Section 402 Sub-Section II Valves and Appurtenances	11/22/02
Approved Material <i>PPG Industries</i>	Division 400, Section 402 Sub-section V Paints and Coatings	7/11/02

BOARD OF WATER SUPPLY

CITY AND COUNTY OF HONOLULU
630 SOUTH BERETANIA STREET
HONOLULU, HI 96843
www.boardofwatersupply.com



September 1, 2022

RICK BLANGIARDI, MAYOR

BRYAN P. ANDAYA, Chair
KAPUA SPROAT, Vice Chair
RAY C. SOON
MAX J. SWORD
NA'ALEHU ANTHONY

JADE T. BUTAY, Ex-Officio
DAWN B. SZEWCZYK, P.E., Ex-Officio

ERNEST Y. W. LAU, P.E.
Manager and Chief Engineer

ELLEN E. KITAMURA, P.E.
Deputy Manager and Chief Engineer 

TO: WHOM IT MAY CONCERN

FROM: ERNEST Y.W. LAU, P.E.
MANAGER AND CHIEF ENGINEER 

SUBJECT: 2002 WATER SYSTEM STANDARD AMENDMENTS

The following amendment to the 2002 Water System Standards is effective immediately for **Oahu only**:

In Division 300, Section 302.29 – CHLORINATION OF WATER PIPELINE, delete **C. Disinfection and Sampling Procedure (For Oahu only)**, amended on December 16, 2020, in its entirety and replace with the following (changes noted in bold):

C. Disinfection and Sampling Procedure (For Oahu only). The disinfection and sampling procedure shall follow the steps below:

Step 1 - Preliminary Flushing (Prior to Chlorination): The mains shall be flushed with maximum available pressure and velocity. Adequacy of turnovers shall be determined by the absence of particles. Turbidity shall be less than 1.0 NTU before chlorination. During all flushing operations, the Manager or the Manager's authorized representative shall determine the rate of water use.

Step 2 - Chlorination: The Contractor shall submit to the Manager, for approval, a sketch showing locations of sampling points and a plan or schedule delineating the method or steps the Contractor proposes to use to accomplish the work. The following methods for chlorination shall be used:

a. The following chlorination and water sample collection procedure shall apply to all water pipeline projects:

Step 1: Chlorinate main by filling with water and introducing chlorine in sufficient quantity to obtain a minimum chlorine concentration of 50 parts per million. Leave chlorinated water in main overnight.

Step 2: Flush main with fresh water until all chlorine has been flushed out as evidenced by the N,N-diethyl-p-phenylenediamine (DPD) test, then collect a water sample while continuing to flush the main.

2002 WATER SYSTEM STANDARD AMENDMENTS

September 1, 2022

Page 2

Step 3: Repeat Steps 1 and 2. After collecting the second water sample, stop flushing and allow the water to stand in the main overnight.

Step 4: Thoroughly flush the main with fresh water until all water that had been standing in the main overnight has been flushed out. Stop flushing and let the water stand in the main for one hour. Collect a water sample.

- b. The main is deemed acceptable and certified when (i) the three consecutive water samples, collected **on different days as reasonably close to 24 hours apart as practical operating conditions allow** under Steps 1 and 2, show no TC (Total Coliform bacteria), no E. coli, less than 200 CFU/ml (Colony Forming Units per ml) of HPC (Heterotrophic Plate Count bacteria) or less than 202 HPC using the MPN (Most Probable Number) method and Turbidity <1.0 NTU and (ii) the sample of water held in the main for one hour, collected under Step 4, also shows no TC, no E. coli, less than 200 CFU/ml of HPC or less than 202 HPC using the MPN method and Turbidity <1.0 NTU..
- c. Chlorination, flushing, sampling and testing will be extended should unsatisfactory results be encountered. Any sample that shows positive TC, E. coli, HPC >200 CFU/ml, HPC >202 MPN or Turbidity > 1.0 NTU is unsatisfactory.
- d. Steps 1 and 2 may be repeated before collecting the one hour hold sample specified in Step 4. Repeating Steps 1 and 2 is recommended in the event samples show the presence of TC and/or E. coli and/or increasing total bacterial results from one sample to the next.
- e. Water samples that show the presence of atypical results, debris, high turbidity or results inconsistent with existing water are subject to reconfirmation. The Manager reserves the right to request and test additional water samples in the interest of safeguarding public health and safety at no additional cost to the Department.
- f. Liquid chlorine, chlorine based liquid disinfectants or calcium hypochlorite that has been tested and certified as meeting the specifications of ANSI/NSF Standard 60, Drinking Water Chemicals – Health Effects, shall be used for the chlorination of the water mains.

If you have any questions, please contact Michael Domion, Support Branch Head, Capital Projects Division at (808) 748-5740, or mdomion@hbws.org.

cc: Kauai, Maui, Hawaii Water Departments

MD:em

cc: Water Quality, Construction, M/E, Design & PR, Supp. Br.

BOARD OF WATER SUPPLY

CITY AND COUNTY OF HONOLULU
630 SOUTH BERETANIA STREET
HONOLULU, HI 96843
www.boardofwatersupply.com



August 22, 2022

RICK BLANGIARDI, MAYOR

BRYAN P. ANDAYA, Chair
KAPUA SPROAT, Vice Chair
RAY C. SOON
MAX J. SWORD
NA'ALEHU ANTHONY

JADE T. BUTAY, Ex-Officio
DAWN B. SZEWCZYK, P.E., Ex-Officio

ERNEST Y. W. LAU, P.E.
Manager and Chief Engineer

ELLEN E. KITAMURA, P.E.
Deputy Manager and Chief Engineer

TO: WHOM IT MAY CONCERN
FROM: ERNEST Y. W. LAU, P.E.
MANAGER AND CHIEF ENGINEER *eyw*
SUBJECT: 2002 WATER SYSTEM STANDARD AMENDMENTS

The following amendment to the 2002 Water System Standards is effective immediately for **Oahu only**:

In Division 200, Subsection 209.02 – PIPE CUSHION, delete Table 200-11 – S4C for PIPE CUSHION in its entirety and replace with the following:

Table 200-11 - S4C for PIPE CUSHION (REV. 8/2022)	
Sieve Size	Total Percent Passing By Weight
1/2"	100
3/8"	90 – 100
No. 16	25 – 45
No. 100	0 – 15

If you have any questions, please contact Michael Domion, Support Branch Head, Capital Projects Division at 748-5740 or mdomion@hbws.org.

cc: Kauai, Maui, Hawaii Water Departments

MD:em

cc: Field Op.
Construction, M/E, Design, Supp. Br.

BOARD OF WATER SUPPLY

CITY AND COUNTY OF HONOLULU
630 SOUTH BERETANIA STREET
HONOLULU, HI 96843
www.boardofwatersupply.com



February 9, 2022

RICK BLANGIARDI, MAYOR

BRYAN P. ANDAYA, Chair
KAPUA SPROAT, Vice Chair
RAY C. SOON
MAX J. SWORD
NA'ALEHU ANTHONY

JADE T. BUTAY, Ex-Officio
DAWN B. SZEWCZYK, Designate Ex-Officio

ERNEST Y. W. LAU, P.E.
Manager and Chief Engineer

ELLEN E. KITAMURA, P.E.
Deputy Manager and Chief Engineer *we*

TO: WHOM IT MAY CONCERN

FROM: ERNEST Y. W. LAU, P.E.
MANAGER AND CHIEF ENGINEER *eyw*

SUBJECT: WATER SYSTEM STANDARDS AMENDMENTS

Effective August 1, 2022, for **O'ahu Only**, approval of construction plans requires compliance with all Water System Standards Amendments in effect, regardless of when the construction plans were received by the Board of Water Supply.

If you have any questions, please contact Michael Domion, Support Branch Head, Capital Projects Division at (808) 748-5740, or mdomion@hbws.org.

cc: Kauai, Maui, Hawaii Water Departments

BOARD OF WATER SUPPLY

CITY AND COUNTY OF HONOLULU
630 SOUTH BERETANIA STREET
HONOLULU, HI 96843
www.boardofwatersupply.com



November 8, 2021

RICK BLANGIARDI, MAYOR

BRYAN P. ANDAYA, Chair
KAPUA SPROAT, Vice Chair
RAY C. SOON
MAX J. SWORD
NA'ALEHU ANTHONY

JADE T. BUTAY, Ex-Officio
ROGER BABCOCK, Jr., Ex-Officio

ERNEST Y. W. LAU, P.E.
Manager and Chief Engineer

ELLEN E. KITAMURA, P.E.
Deputy Manager and Chief Engineer

TO: WHOM IT MAY CONCERN

FROM: ERNEST Y.W. LAU, P.E., MANAGER AND CHIEF ENGINEER
BOARD OF WATER SUPPLY *EYWL*

SUBJECT: 2002 WATER SYSTEM STANDARD AMENDMENTS

The following amendment to the 2002 Water System Standards is effective immediately for Oahu only:

In Division 200 – MATERIALS:

Add new **Section 209.06 CONTROLLED LOW STRENGTH MATERIAL (CLSM)** – Attached.

In Division 300 – CONSTRUCTION:

Delete **Section 302.03.G. Payment** in its entirety and replace with **Section 302.03.G. Use of CLSM** and **Section 302.03.H. Payment** – Attached.

If you have any questions, please contact Michael Domion, Support Branch Head, Capital Projects Division at 748-5740 or mdomion@hbws.org.

Attachment

cc: Kauai, Maui, Hawaii Water Departments

MD:em

cc: Field Op., Const. Br., M/E, Design Br., Supp. Br.

DIVISION 200 - MATERIALS

209.06 CONTROLLED LOW STRENGTH MATERIAL (CLSM).

This section describes furnishing CLSM as self compacted backfill material in utility trenches and other works in lieu of compacted fill, or where indicated in the contract documents or accepted by the Engineer. CLSM shall meet the following:

Portland Cement	303.03.B.1.
Fine Aggregate for Concrete	303.03.B.3.
Water	303.03.B.2.

Aggregates that are different than those specified in Section 303.03.B.3. Concrete Aggregates may be used, subject to acceptance by the Engineer.

CLSM shall include mixture of portland cement, aggregate, and water. Provide flowable CLSM with aggregate in suspension. Proportion CLSM to produce the following:

1. Backfill material that is self-compacting and able to be excavated, in the future, with conventional excavation equipment.
2. Uniform, flowable mixture that is self-leveling when placed.
3. 28-day compressive strength between 50 psi to 150 psi.

Provide CLSM conforming to Section 302.03.G. – Use of CLSM and Section 303.03 – CONCRETE WORK, except as modified in this section.

DIVISION 300 - CONSTRUCTION

G. Use of CLSM. The Contractor shall furnish and place CLSM backfill bedding where shown in the plans and specifications or as directed by the Manager.

Check trench bottom and sides for cracks, voids, or other defects that may cause CLSM to escape trench. Repair all defects and place CLSM upon approval by the Manager. From trench bottom to 12 inches above the top of pipe, full CLSM or full aggregate backfill is required. A mixing of CLSM and aggregate fill layers shall not be applied due to the different stresses that can occur on the pipe at the interface of both types of products.

At utility crossings where proper compaction between the water main and other utilities is difficult to achieve, CLSM shall be installed in place of backfill material and pipe cushion material in accordance to the plans and specifications.

CLSM shall be placed directly into the space to be filled. The placement of CLSM shall include "spading" under the pipe haunches. Care shall be taken to prevent flotation or misalignment of the pipe by means of straps, soil, anchors or other designed and approved means of restraint as per the manufacturer's recommendation. Material may be placed in stages equally on both sides of the pipe to prevent movement or flotation of pipe.

The CLSM shall not be permitted higher than the bottom level of the permeable base layer so as to permit drainage flow through the pavement.

Soil backfill shall not be placed until the CLSM has reached the initial set. If backfill is not to be placed over the CLSM within 8 hours, a 6-inch cover of moist earth shall be placed over the CLSM surface.

H. Payment. No separate payment for pipe cushion, trench backfill, backfill at valve boxes, CLSM and warning tape will be made; the compensation for such work shall be deemed to be included in the Unit Price Bid for TRENCH EXCAVATION (without Classification).

The Manager shall have the authority to withhold payment due or to become due for excavation or slow curing asphalt until the Contractor submits test results that compaction work was properly completed.

BOARD OF WATER SUPPLY

CITY AND COUNTY OF HONOLULU
630 SOUTH BERETANIA STREET
HONOLULU, HI 96843
www.boardofwatersupply.com



July 30, 2021

RICK BLANGIARDI, MAYOR

BRYAN P. ANDAYA, Chair
KAPUA SPROAT, Vice Chair
RAY C. SOON
MAX J. SWORD
NA'ALEHU ANTHONY

JADE T. BUTAY, Ex-Officio
ROGER BABCOCK, Jr., Ex-Officio

ERNEST Y. W. LAU, P.E.
Manager and Chief Engineer

ELLEN E. KITAMURA, P.E.
Deputy Manager and Chief Engineer *EW*

TO: WHOM IT MAY CONCERN

FROM: *EW* ERNEST Y. W. LAU, P.E., MANAGER AND CHIEF ENGINEER *EW*
BOARD OF WATER SUPPLY

SUBJECT: 2002 WATER SYSTEM STANDARDS AMENDMENT

Effective immediately for Oahu Only, the 2002 Water System Standards shall be amended as follows:

DIVISION 100 – PLANNING, Section 111 – WATER REQUIREMENTS:

1. Delete **Table 100-19 – FIRE FLOW REQUIREMENTS** in its entirety and replace with the following **Table 100-19 – FIRE FLOW REQUIREMENTS, REVISED 7/2021 – FOR OAHU ONLY**.

Table 100-19 - FIRE FLOW REQUIREMENTS	
REVISED 7/2021 - FOR OAHU ONLY	
LAND USE	FLOW (GPM)/DURATION (HRS)/FIRE HYDRANT SPACING (FT.)
Agriculture	1,000/0.5/700
Single Family Residential	1,000/1/350
Duplex Residential	1,000/1/350
PUD Townhouse and Low Rise Apartments	1,500/1/250
Schools, Neighborhood Businesses, Small Shopping Centers, Hotels, and High Rise Apartments	2,000/2/250
Light Industry, Downtown Business, Large Shopping Center, and Hospitals	4,000/3/250
Heavy Industry, Hotels	Subject to special review and control by the Manager

Notes:

1. For FH placement on dead-end streets, the last FH shall be located at one half of the spacing distance for FHs from the last parcel, house or unit (frontage property line or to the driveway or access for the property).
2. Spacing of fire hydrant shall be measured along the roadway.
3. Adequate Off-site Fire Protection Distance Requirement: For all existing land uses and developments requiring land use changes, the maximum distance requirement between a FH and the property is as follows:
 - a. Residential – 350 feet
 - b. Commercial and Industrial – 250 feet
 - c. Agricultural – 350 feet

If you have any questions, please contact Michael Domion, Support Branch Head, Capital Projects Division, at 748-5740 or mdomion@hbws.org.

cc: Hawaii, Kauai and Maui Water Departments

MD:em

cc: J. Nikaido
 K. Ihu
 B. Usagawa
 J. Elflein

BOARD OF WATER SUPPLY

CITY AND COUNTY OF HONOLULU
630 SOUTH BERETANIA STREET
HONOLULU, HI 96843
www.boardofwatersupply.com



March 25, 2021

RICK BLANGIARDI, MAYOR

BRYAN P. ANDAYA, Chair
KAPUA SPROAT, Vice Chair
RAY C. SOON
MAX J. SWORD
NA'ALEHU ANTHONY

JADE T. BUTAY, Ex-Officio
ROGER BABCOCK, Jr., Ex-Officio

ERNEST Y. W. LAU, P.E.
Manager and Chief Engineer

ELLEN E. KITAMURA, P.E.
Deputy Manager and Chief Engineer *ll*

TO: WHOM IT MAY CONCERN

FROM: ERNEST Y. W. LAU, P.E.
ll MANAGER AND CHIEF ENGINEER *ll*

SUBJECT: 2002 WATER SYSTEM STANDARD AMENDMENTS

The following amendment to the 2002 Water System Standards is effective immediately for **Oahu only**:

Division 400, Section 403 STANDARDS DETAILS:

Replace Standard Detail M33 with the enclosed Standard Detail **M33 Turbine Meter, Installation-Notes and Tables, 2021 Revision**. The splice length (dimension F) on the table was updated to reflect the laying length of the meter.

If you have any questions, please contact Michael Domion, Support Branch Head, Capital Projects Division at 748-5740, or mdomion@hbws.org.

Enclosure

cc: Kauai, Maui, Hawaii Water Departments

NOTES:

1. SEE M7, M8, M9 AND M10 FOR METER BOX FRAME AND COVER DETAILS. SEE DETAIL M26 FOR METER BOX DETAIL.
2. THE PROJECT SHALL PAY THE APPLICABLE WATER SYSTEM FACILITIES CHARGE AND FOR THE METER WHICH WILL BE FURNISHED BY BWS AND INSTALLED BY THE CONTRACTOR WHEN THE LATERAL IS INSTALLED.
3. LOCATE BY-PASS BALL STOP IN METER BOX WITH ENOUGH SPACE BETWEEN METER AND WALL FOR TEMPORARY BY-PASS STANDPIPE TO BE HOOKED UP.
4. ELIMINATE 4" DRAINHOLES FOR WATERPROOFED MANHOLES.
5. CENTER DIAL UNDER READING COVER.
6. CONTRACTOR SHALL NOTIFY CUSTOMER SERVICE DIVISION IN WRITING AFTER THE PLAN IS APPROVED, NO LATER THAN 120 DAYS, PRIOR TO WITHDRAWING METER FROM THE BWS STOREYARD. SUCH NOTICE SHALL INDICATE NUMBER, SIZE, AND TYPE OF METER AND APPROXIMATE MONTH AND YEAR METER IS ANTICIPATED TO BE DRAWN OUT. IF THE APPROVED PLAN IS ALLOWED TO LAPSE, THE 120-DAY NOTICE WILL BE VOIDED.
7. ALL METERS SHALL BE INSTALLED IN THE CONCRETE OR DIRT SIDEWALK AREA WITH CONCRETE SLAB. (SEE PLATE M43)
8. CONCRETE SHALL BE DWS 3500.
9. REINFORCING STEEL SHALL BE ASTM A615 GRADE 60.
10. DESIGN IS BASED ON: 250 PSF LIVE LOAD; 0 SURCHARGE; 60 PCF/FT AT REST PRESSURE; AND WATER TABLE BELOW BOTTOM SLAB, PER AASHTO LRFD BRIDGE DESIGN SPECIFICATIONS (1998). NON-TRAFFIC TYPE.
11. SPECIAL INSPECTION SHALL BE PROVIDED DURING CONSTRUCTION FOR CMU WALL.
12. STRUCTURAL STEEL SHAPES SHALL BE ASTM A-36. HOT DIP GALVANIZED AFTER FABRICATION.

	TURBINE METERS			
	3"	4"	6"	8"
A	7'-2"	7'-5"	7'-11"	8'-7"
B	4'-0"	4'-6"	4'-6"	4'-6"
C	1'-8 1/2"	1'-9 1/2"	1'-10 3/4"	1'-11"
D	2'-0"	2'-3"	2'-3"	2'-3"
E	3'-6"	3'-6"	3'-0"	3'-0"
F	1'-7"	1'-11"	2'-3"	2'-6 1/8"
G	2"	2 1/2"	2 1/2"	2 1/2"
H	2'-9 1/4"	3'-1"	3'-6"	3'-7"
J	1'-6 1/4"	1'-8 1/2"	1'-11 1/2"	1'-3"
K	2'-6 3/4"	2'-11 1/2"	3'-4 1/2"	2'-10 1/2"
L	24" X 42"	24" X 42"	36" X 52"	36" X 52"
Ø	4"	4" OR 6"	6" OR 8"	8" OR 12"

2021
REVISION

OAHU	TURBINE METER INSTALLATION-NOTES AND TABLES SCALE: NTS	STANDARD DETAILS	M33
------	---	---------------------	------------

BOARD OF WATER SUPPLY

CITY AND COUNTY OF HONOLULU
630 SOUTH BERETANIA STREET
HONOLULU, HI 96843
www.boardofwatersupply.com



February 26, 2021

RICK BLANGIARDI, MAYOR

BRYAN P. ANDAYA, Chair
KAPUA SPROAT, Vice Chair
RAY C. SOON
MAX J. SWORD
NA'ALEHU ANTHONY

JADE T. BUTAY, Ex-Officio
ROGER BABCOCK, Jr., Ex-Officio

ERNEST Y. W. LAU, P.E.
Manager and Chief Engineer

ELLEN E. KITAMURA, P.E.
Deputy Manager and Chief Engineer *Ellen*

Mr. John Bolender, President
J&S Valve, Inc.
2323 1st Street
Huffman, Texas 77336

Dear Mr. Bolender:

Subject: Your Letters Dated April 4, 2020 and February 13, 2021, Regarding
Requesting Inclusion in the Approved Materials List of the Water System
Standards for J&S Valve

Thank you for the additional information to address our concerns with compliance to the Water System Standards. We approve the following J&S valves for inclusion into the Approved Materials List of the Water System Standards:

1. J&S Series 6000 Resilient Seated Gate Valve, AWWA C509, 4-inch to 12-inch only.
2. J&S Series 7800 Metal Seated Rolling Double Disc Gate Valves, AWWA C500, 16" to 42" only.

If you have any questions, please contact Michael Domion, Support Branch Head, Capital Projects Division, at 748-5740 or mdomion@hbws.org.

Very truly yours,

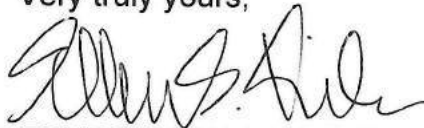
ERNEST Y. W. LAU, P.E.
Manager and Chief Engineer

SERIES 6000 - AWWA C509/C515

SIZES: 2" - 108"

2" OPERATING NUT OR HAND WHEEL

Ductile Iron

STEM

Stainless Steel
(Other Materials, Available)

SEAL PLATE

Ductile Iron

BONNET

Ductile Iron

STEM NUT

Low-Zinc
Aluminum Bronze

WEDGE

Ductile Iron
Encapsulated with
EPDM Rubber
(Other Elastomers, Available)

TRIPLE O-RING STEM SEALS

EPDM
(Other Elastomers, Available)

THRUST COLLAR

with 2 Brass
Thrust Bearing

O-RING GASKET

EPDM
(Other Elastomers, Available)

NUTS, BOLTS, WASHERS

Stainless Steel

BODY

Ductile Iron

COATING

ANSI/NSF-61 Fusion Bond
Epoxy
(Inside and Outside per AWWA C550)

TYPES

Non-Rising Stem (NRS)
or Outside Screw and
Yoke (OS&Y)

END-CONNECTIONS

Flange or Mechanical Joint



Design and Materials Subject to Change Without Notice. Call for Verification and Any Updated Drawings

METAL SEATED ROLLING DOUBLE DISC GATE VALVE

SERIES 7800 • AWWA C500 • NRS TYPE

FLANGED • SIZE 16" TO 48" • BEVEL GEAR • BYPASS

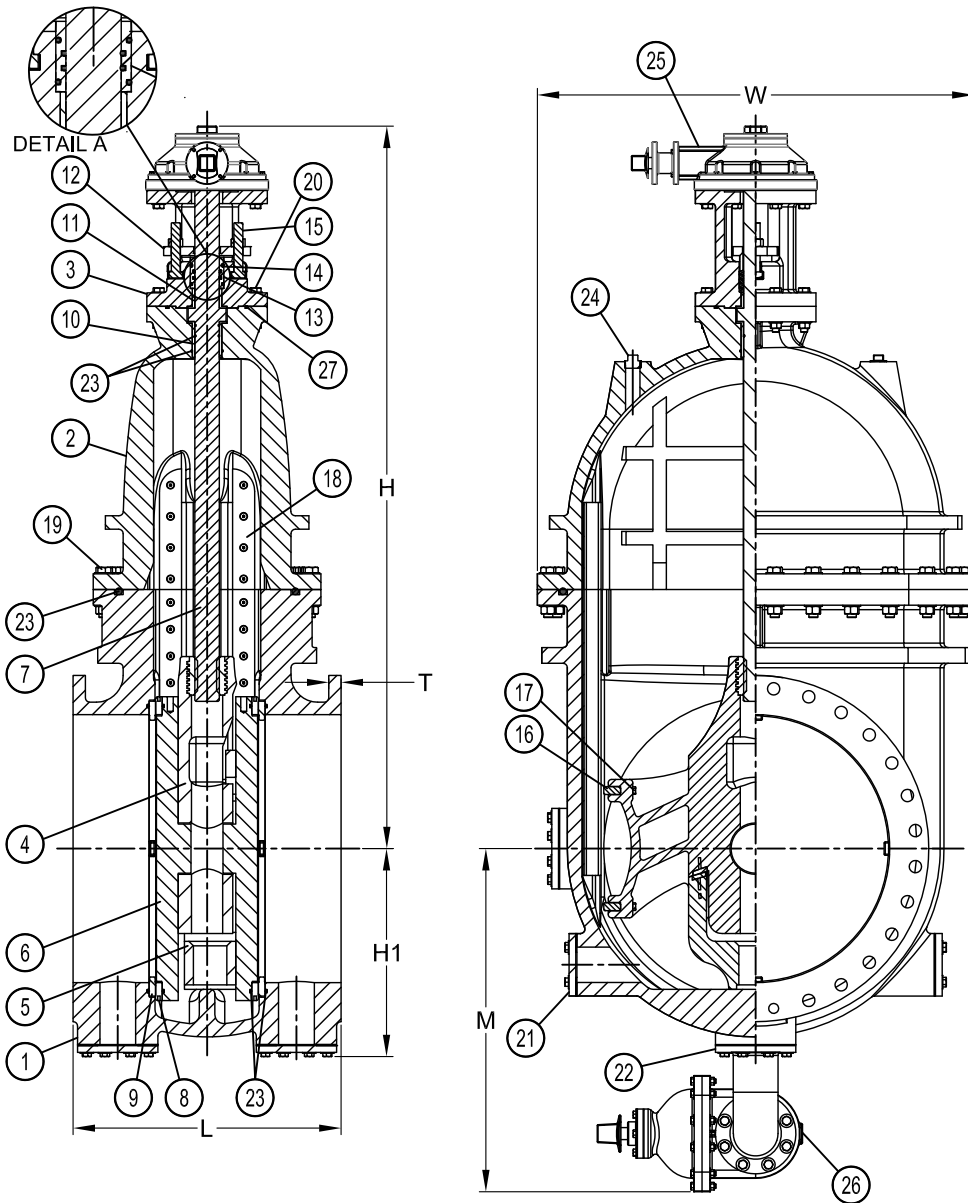

No.	Part Name	Material
1	Body	Ductile Iron ASTM A536 65-45-12
2	Bonnet	Ductile Iron ASTM A536 65-45-12
3	Yoke	Ductile Iron ASTM A536 65-45-12
4	Upper Wedge	Ductile Iron ASTM A536 65-45-12
5	Lower Wedge	Ductile Iron ASTM A536 65-45-12
6	Disc	Ductile Iron ASTM A536 65-45-12
7	Stem	*304 Stainless Steel
8	Disc Seat Ring	Aluminum Bronze
9	Body Seat Ring	Aluminum Bronze
10	Bonnet Bushing	Bronze
11	Yoke Bushing	Bronze
12	Follower Flange	Ductile Iron ASTM A536 65-45-12
13	O-Ring Cartridge	Bronze
14	Upper O-Ring Seal QTY 2	EPDM
15	Gland Bolt, Nut	316 Stainless Steel
16	Scraper	Bronze
17	Scraper Bolt	316 Stainless Steel
18	Track, Screw	316 Stainless Steel
19	Bolt, Nut, Washer	316 Stainless Steel
20	Bolt, Nut, Washer	316 Stainless Steel
21	Clean-Out Port Cover	Ductile Iron ASTM A536 65-45-12
22	Bypass Port Cover	Ductile Iron ASTM A536 65-45-12
23	Lower O-Ring Seal	EPDM
24	1-1/2" NPT Plug	Brass
25	Bevel Gear	Assembly
26	Bypass AWWA C500	Assembly
27	O-Ring	EPDM

*Bronze Stem Available

Size	Model	L	H	H1	W	M	Approx. Weight(lbs.)
16"	7816	20"	49 1/2"	13 7/8"	27 1/2"	26 1/2"	1,550
18"	7818	22"	54 1/2"	14 7/8"	31 1/4"	27 1/2"	2,060
20"	7820	24"	59"	16 7/8"	34 3/4"	29 1/2"	2,855
24"	7824	27"	66 1/2"	19 1/8"	39 5/8"	33 3/4"	3,762
30"	7830	30"	81"	23 5/16"	48 1/8"	38 7/16"	7,111
36"	7836	33"	89 3/4"	26 3/4"	56 1/4"	42 1/8"	10,105
42"	7842	36"	106 1/4"	30 1/4"	63 15/16"	47 1/8"	14,738
48"	7848	40"	116 1/4"	36 1/16"	71 1/2"	64 1/2"	20,044

Features:

- Design and Materials Exceed AWWA C500.
- Flange Ends Conform to ASME B16.1 Class 125 and ANSI / AWWA C110 / A21.10.
- Epoxy Coatings In and Out per AWWA C550.
- Valve Dimensions are Approximate and Must be Verified Before Installation.
- 250 PSI Working Pressure.
- ANSI / NSF 61 Certified.



2323 1st Street, Huffman, TX 77336
281-324-3990 www.JANDSValve.com

Drawn By: J. Cota Date: 4-6-20

S.O. No.:

Project:

Metal Seated Rolling Double Disc Gate Valve AWWA C500 Series 7800 16" to 48" with Bevel Gear, Bypass, Flanged

REV

A

BOARD OF WATER SUPPLY

CITY AND COUNTY OF HONOLULU
630 SOUTH BERETANIA STREET
HONOLULU, HI 96843
www.boardofwatersupply.com



December 16, 2020

KIRK CALDWELL, MAYOR

BRYAN P. ANDAYA, Chair
KAPUA SPROAT, Vice Chair
RAY C. SOON
MAX J. SWORD

ROSS S. SASAMURA, Ex-Officio
JADE T. BUTAY, Ex-Officio

ERNEST Y. W. LAU, P.E.
Manager and Chief Engineer

ELLEN E. KITAMURA, P.E.
Deputy Manager and Chief Engineer *llr*

TO: WHOM IT MAY CONCERN

FROM: ERNEST Y. W. LAU, P.E. *eyw*
MANAGER AND CHIEF ENGINEER

SUBJECT: 2002 WATER SYSTEM STANDARDS AMENDMENT

Effective immediately for Oahu Only, the 2002 Water System Standards shall be amended as follows:

DIVISION 300 – CONSTRUCTION, Section 302.29 – CHLORINATION OF WATER PIPELINE:

- o Delete **C. Disinfection and Sampling Procedure (For Oahu only)** and replace with the following:
- C. Disinfection and Sampling Procedure (For Oahu only).** The disinfection and sampling procedure shall follow the steps below:

Step 1 - Preliminary Flushing (Prior to Chlorination): The mains shall be flushed with maximum available pressure and velocity. Adequacy of turnovers shall be determined by the absence of particles. Turbidity shall be less than 1.0 NTU before chlorination. During all flushing operations, the Manager or the Manager's authorized representative shall determine the rate of water use.

Step 2 - Chlorination: The Contractor shall submit to the Manager, for approval, a sketch showing locations of sampling points and a plan or schedule delineating the method or steps the Contractor proposes to use to accomplish the work. The following methods for chlorination shall be used:

- a. The following chlorination and water sample collection procedure shall apply to all water pipeline projects:

Step 1: Chlorinate main by filling with water and introducing chlorine in sufficient quantity to obtain a minimum chlorine concentration of 50 parts per million. Leave chlorinated water in main overnight.

Step 2: Flush main with fresh water until all chlorine has been flushed out as evidenced by the N,N-diethyl-p-phenylenediamine (DPD) test, then collect a water sample while continuing to flush the main.

Step 3: Repeat Steps 1 and 2. After collecting the second water sample, stop flushing and allow the water to stand in the main overnight.

Step 4: Thoroughly flush the main with fresh water until all water that had been standing in the main overnight has been flushed out. Stop flushing and let the water stand in the main for one hour. Collect a water sample.

- b. The main is deemed acceptable and certified when (i) the three consecutive water samples, collected 24 hours apart under Steps 1 and 2, show no TC (Total Coliform bacteria), no E. coli, less than 200 CFU/ml (Colony Forming Units per ml) of HPC (Heterotrophic Plate Count bacteria) or less than 202 HPC using the MPN (Most Probable Number) method and Turbidity <1.0 NTU and (ii) the sample of water held in the main for one hour, collected under Step 4, also shows no TC, no E. coli, less than 200 CFU/ml of HPC or less than 202 HPC using the MPN method and Turbidity <1.0 NTU.
- c. Chlorination, flushing, sampling and testing will be extended should unsatisfactory results be encountered. Any sample that shows positive TC, E. coli, HPC >200 CFU/ml, HPC >202 MPN or Turbidity > 1.0 NTU is unsatisfactory.
- d. Steps 1 and 2 may be repeated before collecting the one hour hold sample specified in Step 4. Repeating Steps 1 and 2 is recommended in the event samples show the presence of TC and/or E. coli and/or increasing total bacterial results from one sample to the next.
- e. Water samples that show the presence of atypical results, debris, high turbidity or results inconsistent with existing water are subject to reconfirmation. The Manager reserves the right to request and test additional water samples in the interest of safeguarding public health and safety at no additional cost to the Department.
- f. Liquid chlorine, chlorine based liquid disinfectants or calcium hypochlorite that has been tested and certified as meeting the specifications of ANSI/NSF Standard 60, Drinking Water Treatment Chemicals – Health Effects, shall be used for the chlorination of the water mains.

- o Delete **H. Payment** and replace with the following:

H. Payment (For Oahu only). Payment for all items of work in this section shall not be paid for directly but shall be considered incidental and included in the prices bid for the various items of work in the Proposal. This shall represent full compensation for furnishing all materials and for all labor, tools, equipment and incidentals required for the chlorination and flushing of the water system inclusive of all incidental work. No additional payment will be made due to repeat operations. The Contractor shall provide and install at the Contractor's own expense all water supply equipment and materials, including all temporary pipes and fittings and all pumping facilities which are necessary for transporting water from the nearest available source to the project site. All water used for chlorination and flushing that is furnished by the BWS at the nearest available source, the Contractor shall be charged for the water used.

If you have any questions, please contact Michael Domion, Support Branch Head, Capital Projects Division, at 748-5740 or mdomion@hbws.org.

cc: Hawaii, Kauai and Maui Water Departments

BOARD OF WATER SUPPLY

CITY AND COUNTY OF HONOLULU
630 SOUTH BERETANIA STREET
HONOLULU, HI 96843
www.boardofwatersupply.com



October 5, 2020

KIRK CALDWELL, MAYOR

BRYAN P. ANDAYA, Chair
KAPUA SPROAT, Vice Chair
RAY C. SOON
MAX J. SWORD

ROSS S. SASAMURA, Ex-Officio
JADE T. BUTAY, Ex-Officio

ERNEST Y. W. LAU, P.E.
Manager and Chief Engineer

ELLEN E. KITAMURA, P.E.
Deputy Manager and Chief Engineer

TO: WHOM IT MAY CONCERN

FROM: ERNEST Y. W. LAU, P.E., MANAGER AND CHIEF ENGINEER
BOARD OF WATER SUPPLY *EYWL*

SUBJECT: 1991 WATER SYSTEM EXTERNAL CORROSION CONTROL
STANDARDS AMENDMENT

For **Oahu Only**, the 1991 Water System External Corrosion Control Standards shall be amended to require a bonded dielectric coating for ductile iron pipes and fittings in combination with the required cathodic protection. The bonded dielectric coating shall be a 100% solids polyurethane or epoxy, and shall be in lieu of polyethylene encasement or a bonded tape coating. The bonded dielectric coating requirements shall be in accordance with the enclosure specifications.

All construction plans received by the Board of Water Supply after October 30, 2020, shall comply with the above amendments.

If you have any questions, please contact Michael Domion, Support Branch Head, Capital Projects Division, at 748-5740 or mdomion@hbws.org.

Enclosure

cc: Hawaii, Kauai and Maui Water Departments

MD:em

cc: M. Fuke, K. Ihu, B. Usagawa
Construction, Design and Plans Review, Support, M/E

BONDED DIELECTRIC COATING

SECTION 1. GENERAL

1.1 Overview

- 1.1.1 The Contractor shall furnish all tools, equipment, materials, and supplies and shall perform all labor required to complete the exterior 100% solids polyurethane or epoxy shop coating application on new ductile iron water transmission pipeline to be buried in soil. This specification also requires field touchups on damaged coatings. This work shall include all precleaning, surface preparation, coating application on ferrous surfaces, protection of surfaces not to be coated, cleanup, and appurtenant work, in accordance with the requirements of the Contract Documents.
- 1.1.2 The ductile iron pipe shall be provided to the coating applicator without an asphaltic coating.
- 1.1.3 All coatings, solvents, equipment, and procedures necessary to complete the work specified in the Contract Documents shall be suitable for potable water and soil exposure.
- 1.1.4 The coating system schedules summarize the surfaces to be coated, the required surface preparation, and the coating systems to be applied. Coating notes on the drawings are used to show exceptions to the schedules, to show or extend the limits of coating systems, or to clarify or show details for application of the coating systems.

1.2 Definitions

- 1.2.1 Contractor shall be defined as the coating applicator in the shop and the field applicator for touch ups.
- 1.2.2 Inspector shall be defined as a Quality Assurance/Quality Control person knowledgeable with SSPC and NACE standards and general coating industry standards. This person may be retained by BWS, shop applicator, or by the pipe installer.
- 1.2.3 Touchup shall be defined as a repair made by the shop applicator or field installer. The criteria for repairs are as defined in paragraphs 3.11 and 3.12.

1.3 Reference Specification, Codes, and Standards

ASTM International	
D2240	Standard Test Method for Rubber Property – Durometer Hardness
D4414	Standard Practice for Measurement of Wet Film Thickness of Organic Coatings by Notched Gauges
D4541	Standard Test Method for Pull-Off Strength of Coatings Using Portable Adhesion Testers
D5402	Standard Practice for Assessing the Solvent Resistance of Organic Coatings Using Solvent Rubs
D7393	Standard Practice for Indicating Oil in Abrasives

Code of Federal Regulations Title 40, Environmental Protection Agency
40CFR Part 59 Table 1 – VOC Content Limits for Industrial Coatings

National Association of Corrosion Engineers (NACE) International

- SP0188 Discontinuity (Holiday) Testing of New Protective Coatings on Conductive Substrates
- SP0287 Field Measurements of Surface Profile of Abrasive Blast Cleaned Steel Surfaces Using Replica Tape

National Association of Pipe Fitters

- 500-03 Surface Preparation Standard for Ductile Iron Pipe and Fittings in Exposed Locations Receiving Special External Coatings and/or Special Internal Linings

SSPC - Steel Structures Painting Council, the Society for Protective Coatings

- PA1 Shop, Field, and Maintenance Painting of Steel
- PA2 Procedure for Determining Conformance to Dry Coating Thickness Requirements
- SP1 Solvent Cleaning
- SP2 Hand Tool Cleaning
- SP3 Power Tool Cleaning
- SP7 Brush Off Blast Cleaning
- SP11 Power Tool Cleaning to Bare Metal
- Vol. 1 Good Painting Practice

1.4 Contractor Submittals

1.4.1 Qualifications of the Shop Applicator

- 1.4.1.1 Letter identifying the person responsible for Quality Assurance/Quality Control (QA/QC) at the shop coating facility. This person shall have a minimum of 10 years of experience in the surface preparation of metals and application of the specified coatings. This person shall have a SSPC or NACE training certification and shall be familiar with the industry standards. This person will be responsible for submitting QA/QC documentation to the Owner.
- 1.4.1.2 A copy of a typical QA/QC inspection report containing inspection items listed in Paragraph 3.10 of this Specification.
- 1.4.1.3 Three references which verify that the shop painting facility has demonstrated successful application of the specified coating systems in the past 5 years. Provide the structure name and size (area of coating), time of completion, the owner's name, address, and telephone number for each installation referenced.
- 1.4.1.4 The manufacturer shall provide written certification that the shop painting facility's supervisor and each applicator performing Work on the project have been trained and approved by the manufacturer to apply the selected coating system.
- 1.4.1.5 A written certification from the shop painting facility stating that it is qualified and experienced in the application of the specified coating systems.

- 1.4.1.6 The Contractor shall provide a letter states the type of mixing, spraying, heating, and environmental control equipment for the specified coating products.
- 1.4.2 Complete data on each type and kind of paint, and materials shall be submitted for review. Acceptance shall be received from BWS before the paint is applied. This procedure must be followed whether or not the paint that the Contractor proposes to use is named in the Contract Documents. Submitted data shall show where and for what uses each paint product is proposed with cross-reference made to sections of these Specifications. Paint material submittals shall include the following:
 - 1.4.2.1 Safety data sheets for all products used at the jobsite, including paints, thinners, solvents, and cleaners.
 - 1.4.2.2 Product Data Sheets for all coating products with the following information:
 - 1.4.2.2.1 Surface preparation requirements for immersion service or severe environments
 - 1.4.2.2.2 Minimum and maximum wet and dry film thickness per coat
 - 1.4.2.2.3 Minimum and maximum cure, induction, and pot lifetimes
 - 1.4.2.2.4 Temperature and humidity requirements during and after application
 - 1.4.2.2.5 Proper storage and shelf life at various temperatures
 - 1.4.2.2.6 EPA Method 24 results to verify compliance with 40 CFR 59 for VOC's
 - 1.4.2.2.7 Tensile, elongation, moisture vapor transmission rate, and abrasion testing results.
- 1.4.3 Manufacturer's product data sheet for each abrasive material to be used with the following:
 - 1.4.3.1 Technical data sheet for each product used, including statements on the suitability of the material for the intended use.
 - 1.4.3.2 State and country of origin.
 - 1.4.3.3 Safety data sheet for each product, if applicable.
 - 1.4.3.4 Size/mesh and percentage by weight of each component
- 1.4.4 Paint Manufacturer's Information: For each paint system to be used, the Contractor shall submit the following listed data at least 30 days prior to coating:
 - 1.4.4.1 Paint manufacturer's technical application instructions for application, heating materials, mixing, spray tip sizes, and hose pressures.

1.4.4.2 The manufacturer shall provide written certification that the coating Contractor's supervisor and each applicator performing Work on the project have been trained and approved by the manufacturer to apply the selected coating system. The manufacturer shall state whether or not it has verified that the Contractor is going to use the proper mixing, coating application, heating, and environmental control equipment for the specified coating products.

1.4.4.3 Drawing details for field repairs or coating terminations at joints, fittings, or special pipe sections (where applicable).

1.5 Safety and Health Requirements

1.5.1 Head and face protection and respiratory devices shall include protective helmets conforming to the requirements of ANSI Z 89.1, which shall be worn by all persons at all times while in the vicinity of the work. In addition, workers engaged in or near the work during abrasive blasting shall wear eye and face protection devices meeting the requirements of ANSI Z 87.1 and a respirator with appropriate filter.

1.5.2 Where ventilation is used to control potential exposures to workers, as set forth in Section 1910.94 of the OSHA Regulations for Construction, ventilation shall be adequate to reduce the concentration of the air contaminant to the degree that a hazard to the worker does not exist. Methods of ventilation shall meet the requirements set forth in ANSI Z9.2.

SECTION 2. PRODUCTS

2.1 General

2.1.1 Definitions: The term "paint," "coatings," or "finishes," as used herein, shall include surface treatments, paints, and all other protective coatings, whether used as a pretreatment, primer, intermediate coat, or finish coat. The term "DFT" means minimum dry film thickness.

2.1.2 General: Coating materials shall be sealed in new containers that plainly show the designated name, formula or specification number, batch number, color, date of manufacture, manufacturer's directions, and name of manufacturer, all of which shall be plainly legible at the time of use.

2.1.3 The Contractor shall use coating materials suitable for the intended use and recommended by their manufacturer for buried and groundwater environments. Materials shall be delivered unopened to the applicator in their original containers bearing the manufacturer's label, completely identifying the contents, date of manufacture, volatile organic compounds (VOCs), and listing directions for their proper use. No products shall be allowed on site that do not conform with 40 CFR Part 59.

2.1.4 Compatibility: In any coating system, only compatible materials from a single manufacturer shall be used in the work. Particular attention shall be directed to compatibility of all applied coats.

- 2.1.5 Protective Coating Materials: Products shall be standard products produced by recognized manufacturers who are regularly engaged in production of such materials for essentially identical service conditions. Where requested, the Contractor shall provide BWS with the names of not less than 5 successful applications of the proposed manufacturer's products demonstrating compliance with this specification requirements.
- 2.1.6 Substitute or "Or-Equal" Submittals: Unless otherwise specified, materials are from the catalogs of the companies listed herein. Materials by other manufacturers are acceptable provided that they are established as being compatible with and of equal quality to the coatings of the companies listed. The Contractor shall provide satisfactory documentation from the firm manufacturing the proposed substitute or "or-equal" material that said material meets the specified requirements and is equivalent or better than the listed materials in the following properties:
 - 2.1.6.1 Minimum and maximum cure times before immersion
 - 2.1.6.2 Moisture vapor transmission rate per ASTM D1653 Method B at 40 mils minimum
 - 2.1.6.3 Abrasion resistance per ASTM D4060 using a CS17 wheel
 - 2.1.6.4 Minimum and maximum recoat times
 - 2.1.6.5 Ability to recoat in future
 - 2.1.6.6 Solids content by volume
 - 2.1.6.7 Dry film thickness per coat
 - 2.1.6.8 Compatibility with other coatings
 - 2.1.6.9 Suitability for the intended service
 - 2.1.6.10 Resistance to chemical attack
 - 2.1.6.11 Temperature limitations in service and during application
 - 2.1.6.12 Ease of application
 - 2.1.6.13 Ease of repairing damaged areas
- 2.1.7 The cost of all testing and analysis of the proposed substitute materials that may be required by BWS shall be paid by the Contractor. If the proposed substitution requires changes in the contract work, the Contractor shall bear all such costs involved and the costs of allied trades affected by the substitution.

2.2 Industrial Coating System Substitute Materials

2.2.1 Material Sources: Each of the following manufacturers is capable of supplying many of the industrial coating materials specified herein. Where manufacturers and paint numbers are listed, it is to show the type and quality of coatings that are required. Proposed substitute materials must be shown to satisfy the material descriptions and to equal or exceed the properties of the listed materials as required in the paragraph entitled "Substitute or 'Or-Equal' Submittals" herein.

2.2.1.1 Induron

2.2.1.2 International Protective Coatings

2.2.1.3 Raven Lining Systems

2.2.1.4 Sherwin Williams

2.2.1.5 Tnemec

2.3 Coating Systems

2.3.1 E100: A 100% solids epoxy to be used to coat the exterior surfaces of pipe exposed to corrosive soil conditions. The epoxy shall have a moisture vapor transmission rate less than 3 grams per square meter per 24 hours ($\text{g}/\text{m}^2/24 \text{ hr}$) as measured per ASTM D1653 Method B at a thickness of 60 mils. Approved products include the following:

2.3.1.1 Finish Coat (DFT 40 mils): Carboline Plasite 4500, Induron Ceramawrap Epoxy, Tnemec Series FC22 Epoxoline, or approved equal.

2.3.1.2 Total System DFT: 40 mils.

2.3.2 P100: A 100% solids polyurethane to be used to coat the exterior surfaces of pipe exposed to corrosive soil conditions. The polyurethane shall have a moisture vapor transmission rate less than 6 grams per square meter per 24 hours ($\text{g}/\text{m}^2/24 \text{ hr}$) as measured per ASTM D1653 Method B at a thickness of 40 mils. Abrasion resistance shall be less than 55 mg loss per ASTM D4060 using a CS17 1,000 g wheel. Approved products include the following:

2.3.2.1 Finish Coat (DFT 40 mils): Carboline Polyclad 777, Lifelast Durashield 210, or ITW Polyspec/Futura Coatings Protec II, Sherwin Williams Polycote 110, or approved equal.

2.3.2.2 Total System DFT: 40 mils.

SECTION 3. EXECUTION

3.1 Storage, Mixing, and Thinning of Materials

- 3.1.1 **Plural Component Application Products:** After each component of the coating system has been thoroughly heated, the Contractor shall perform a paint pump ratio test on the first day of spraying and at least once a week thereafter in the presence of the Inspector. The Contractor shall set up two see-through containers with preprinted volumetric marks on a flat surface. The hose valve for each component shall be opened simultaneously and each component flow rate shall be allowed to stabilize by pouring the discharging materials into separate disposable containers. After the flow is stabilized, the hoses shall be transferred to the pre-printed volumetric containers and the valves shall be shut off after one of the containers has been filled to 32 or 48 fluid ounces, depending on the mixing ratio recommended by the manufacturer. If the volumetric quantity of coating in the containers does not match the manufacturer's recommendation, the Contractor shall reduce or increase the pressure and temperature until it meets the specified mixing ratio. No spraying shall be performed until the ratio test result has been accepted by the Inspector.
- 3.1.2 **Manufacturer's Recommendations:** Unless otherwise specified herein, the coating manufacturer's printed recommendations and instructions for thinning, mixing, handling, applying, and protecting its coating materials, for preparation of surfaces for coating, and for all other procedures relative to coating shall be strictly observed. The Contractor shall supply BWS with copies of each manufacturer's instructions.
- 3.1.3 **Thinning of paint** shall be in accordance with the manufacturer's published instructions, especially as to the amount and kind of thinner used.
- 3.1.4 **All protective coating materials** shall be used within the manufacturer's recommended shelf life. Materials exceeding the storage life recommended by the manufacturer shall be removed from the jobsite.
- 3.1.5 **Storage and Mixing:** Coating materials shall be protected from exposure to temperatures greater than or less than the manufacturer's recommendations and shall be thoroughly stirred, strained, and kept at a uniform consistency during application. Coatings of different manufacturers shall not be mixed together. Flammable materials shall be stored in accordance with state and local codes.

3.2 Preparation for Coating

- 3.2.1 **All surfaces to receive protective coatings** shall be cleaned as specified herein prior to application of said coatings. The Contractor shall examine all surfaces to be coated and shall correct all surface defects before application of any coating material. All slivers, sharp edges, gouges, sharp peaks, or burrs shall be grinded down.
- 3.2.2 **Surface preparation** shall be approved by the Inspector prior to application of coating.
- 3.2.3 **The Contractor** shall remove and dispose of all debris from abrasive blasting and other surface preparation prior to coating.
- 3.2.4 **Protection of Surfaces Not to Be Coated:** Surfaces that are not to receive protective coatings shall be protected during surface preparation, cleaning, and coating operations.

- 3.2.5 Care shall be exercised not to damage adjacent work during blast cleaning operations. Spray painting shall be conducted under carefully controlled conditions. The Contractor shall be fully responsible for and shall promptly repair any and all damage to adjacent work or adjoining property occurring from blast cleaning or coating operations.
- 3.2.6 Protection of Painted Surfaces: Cleaning and coating shall be so programmed that dust and other contaminants from the cleaning process will not fall on wet, newly-coated surfaces.

3.3 Environmental Requirements

- 3.3.1 No coating work shall be performed under the following conditions:
 - 3.3.1.1 Surface or ambient temperatures exceed the manufacturer's recommended maximum or minimum allowable.
 - 3.3.1.2 Dust or smoke laden atmosphere.
 - 3.3.1.3 Damp or humid conditions, where the relative humidity is above the manufacturer's maximum allowable.
 - 3.3.1.4 Substrate and ambient temperatures are less than 5°F above the dewpoint and are decreasing. Dewpoint shall be measured by use of an instrument such as a Sling Psychrometer in conjunction with U.S. Department of Commerce, Weather Bureau psychrometric tables. Elcometer 319 Dew Point meter or equal may also be used.
 - 3.3.1.5 Ambient temperature that is expected to drop below 50°F or less than 5°F above the dewpoint within 8 hours after application of coating.

3.4 Specials, Fittings, and Connections

- 3.4.1 Coating and lining application for special sections, connections, and fittings for steel or ductile iron pipe shall conform to coating system and application requirements as specified in this section.
- 3.4.2 Specials, fittings, and connections shall be defined as any pipe section with turnouts for blow offs, interconnects, any valve or other appurtenances, tees, crosses, wyes, laterals, mitered angles or elbows, and pipes which require special fabrication that prevents mechanical production application of the specified system from end to end of pipe joint.
- 3.4.3 Hand-applied tape coatings applied at the shop will not be permitted on any specials, fittings, connections, and elbow fittings unless it has been previously approved by BWS.
- 3.4.4 Special, fittings, and connections shall be shop coated with the E100 or P100 coating system.

3.5 Metal Surface Preparation

- 3.5.1 The Shop Painting Facility shall remove all water, grease, dust, and other contaminants from the surfaces prior to centrifugal or manual abrasive blast cleaning. All oil, grease, and other surface contaminants shall be removed by solvent cleaning per SSPC SP1 prior to blast cleaning.

- 3.5.2 All sharp edges shall be rounded or chamfered, and all slivers and surface defects shall be ground smooth prior to blast cleaning. Rust, scale, welding slag, and spatter shall be removed, and the surface prepared by SSPC SP2, Hand Tool Cleaning, and SSPC SP3, Power Tool Cleaning.
- 3.5.3 The pipe surfaces shall be abrasive blast cleaned per NAPF 500-03-04 with the following exceptions stated in this specification. The Contractor shall use 20/40 glass or 30/60 steel shot material to remove all rust staining, and to achieve a minimum of a 3-mil surface profile. The surface shall be free of all visible dust, loose annealing oxide, loose mold coating, or other foreign matter. The abrasive shall be tested in accordance with ASTM D7393 and shall not contain any oil or emulsion on the surface. The abrasive shall not be reused if oil is present in the jar test.
- 3.5.4 Cast ductile iron fittings shall be abrasive blast cleaned per NAPF 500-03-05 Blast Clean #1 with the following exceptions stated in this specification. The Contractor shall use 20/40 glass or 30/60 steel shot material to remove all rust staining, and to achieve a minimum of a 3-mil surface profile. The surface shall be free of all visible dust, loose annealing oxide, loose mold coating, or other foreign matter. The abrasive shall not be reused unless otherwise approved by the Inspector.
- 3.5.5 If the ductile iron pipe has an asphaltic coating, it shall be removed at no additional cost to BWS.
- 3.5.6 Blast cleaned metal surfaces shall be painted before any rusting or other contamination of the surface occurs.
- 3.5.7 During abrasive blasting, the surface profile shall be tested with the use of Press-o-Film as manufactured by Testex, or other NACE SP0287 approved equal, on 30% of the pipe sections. A minimum of three tests shall be conducted at the beginning, middle, and end of the work shift. The replica tape thickness shall be measured using a dial micrometer manufactured by Testex, or other ASTM D4417 Type C approved equal. For each test area, three replica tape tests shall be performed along the length of the pipe section. For each pipe section, the three replica tape thickness values shall be recorded and the average of the three tests must be within 10% of the coating manufacturer's recommended profile. If the average is below the recommended profile, additional abrasive blasting shall be performed to meet the recommended profile.
- 3.5.8 Compressed air for air blast cleaning shall be supplied at adequate pressure from well-maintained compressors equipped with oil/moisture separators that remove at least 95% of the contaminants. The Inspector shall conduct a blotter test to confirm the cleanliness of the air stream per ASTM D4285.
- 3.5.9 Surfaces shall be cleaned of all dust and residual particles from the cleaning operation by dry air blast cleaning, vacuuming, or another approved method prior to painting. The quantity and size of dust shall be tested in accordance with ISO 8502-3 and shall be Class 2 to Class 0 before proceeding.
- 3.5.10 Enclosed areas and other areas where dust settling is a problem shall be vacuum-cleaned and wiped with a tack cloth.

3.6 Workmanship

- 3.6.1 Each coat shall be subject to the inspection and approval of the Inspector before the next succeeding coat is applied. Defective work of any kind shall be deemed sufficient cause for completely stripping, preparing, and recoating the entire surface involved. Sufficient time shall be allowed between coats to assure proper drying for optimum bonding of the subsequent coats as recommended by the manufacturer for the existing ambient conditions. Excessive time beyond the manufacturer's recommended recoat window shall be avoided. When maximum recommended drying times are exceeded, surfaces shall be abraded for subsequent coats as recommended by the manufacturer.
- 3.6.2 All work shall be done in a professional manner with high quality workmanship leaving the finished surfaces free from runs, drops, ridges, waves, holidays, laps, brush marks, and variations in color, texture, and finish. No visual holes, bubbles, or blisters shall be allowed to be exposed to soil.
- 3.6.3 Skilled craftsmen and experienced supervision shall be used on all work.
- 3.6.4 Clean drop cloths shall be used to cover adjacent structures. All damage to surfaces resulting from the work hereunder shall be cleaned, repaired, and refinished to their original condition.
- 3.6.5 All coatings shall be applied under dry and dust-free conditions. Coating shall be done in a workmanlike manner so as to produce an even film of uniform thickness. Edges, corners, crevices, and joints shall receive special attention to ensure that they have been thoroughly cleaned and that they receive an adequate thickness of coating material.

3.7 Surfaces Not to be Coated

- 3.7.1 The following surfaces shall not be protective coated hereunder unless shown or specified herein or elsewhere in the Contract Documents. The following exterior surfaces shall be masked off by the Contractor prior to coating work being performed on adjacent surfaces requiring coating:
 - 3.7.1.1 Push-on Joints, spigot end – Length of uncoated area shall vary with diameter of pipe. Do not coat surface covered by bell end of pipe or apply less than 10 mils DFT.
 - 3.7.1.2 Push-on Joints, bell end – flush with bell end
 - 3.7.1.3 Welded Flange Joint, spigot end – 3 inches minimum
 - 3.7.1.4 Welded Flange Joint, bell end – 4 inches minimum
- 3.7.2 Valve gaskets or seals, mating surfaces of flanges, bolt holes, drains, or manhole seats, which are not to be painted, shall be masked off prior to coating work.

3.8 Application of Spray-applied Coatings

- 3.8.1 Materials and supplies provided shall be the standard products of the manufacturer. Materials within a coating system shall be the products of a single manufacturer.

- 3.8.2 The application of protective coatings to metal substrates shall be in accordance with SSPC PA1, Shop, Field, and Maintenance Painting of Steel.
- 3.8.3 The Contractor shall perform the pump ratio check prior to spraying any coating material on the pipes. Procedures are given in Paragraph 3.1.A of this specification.
- 3.8.4 Before the start of the coating application each day, the Contractor shall set up polyethylene sheet or cardboard on the ground for the purpose of performing a test patch. The Contractor, in the presence of the Inspector, shall spray on the polyethylene sheet or cardboard and shall not have any discoloration, bubbles, or pinholes in the coating and the spray gun shall not clog. The spray gun shall produce an even fan spray and the coating shall be of a consistent color. After these performance characteristics are achieved, the coating application may proceed.
- 3.8.5 No coating shall be applied under conditions which, in the opinion of the Inspector, could jeopardize the appearance or quality of the finish in any way. It is necessary for the Contractor to provide a working area which meets the manufacturer's recommended environmental conditions. It is the Contractor's responsibility to maintain the proper ambient conditions required by the coating manufacturer.
- 3.8.6 Cleaned surfaces and all coats shall be inspected prior to each succeeding coat. The Contractor shall schedule such inspection with the Inspector in advance.
- 3.8.7 Blast cleaned ferrous metal surfaces shall be painted before any rusting or other deterioration of the surface occurs. Blast cleaning shall be limited to only those surfaces that can be coated in the same work week unless environmental controls are implemented.
- 3.8.8 Coatings shall be applied in accordance with the manufacturer's instructions and recommendations and this Section, whichever has the most stringent requirements.
- 3.8.9 The Contractor shall verify the wet film thickness with a notched gauge in conformance with ASTM D4414. A minimum of one wet film thickness reading shall be recorded on 30% of the pipe segments.
- 3.8.10 Special attention shall be given to edges, and other places where insufficient film thicknesses are likely to be present. Use stripe painting for these areas.
- 3.8.11 Special attention shall be given to materials which will be joined so closely that proper surface preparation and application are not possible. Such contact surfaces shall be coated prior to assembly or installation.
- 3.8.12 Finish coats, including touch-up and damage repair coats shall be overlapped 6 inches onto existing coatings and shall be applied in a manner that will present a uniform texture and color matched appearance.
- 3.8.13 The coating shall be smooth and free of sharp protrusions. It shall not exhibit any cracking, delamination, orange peeling, blisters, off-ratio discoloring, sticky areas, bubbles, craters, or pinholes. Sags and curtaining shall be less than 1% of total coated surface area for each pipe section. If any of the above defects exceed 1% of the total coated surface area of a pipe section, the pipe section shall be rejected.

- 3.8.14 Damaged shop coating that exposes the metal substrate greater than 1 inch in diameter or length shall be cleaned in accordance with SSPC SP11 using an MBX Bristleblaster, or equivalent, and in accordance with the manufacturer's recommendations.

3.9 Exterior Field Joint Coating

- 3.9.1 Pipe joints shall be field-coated after the pipe has been installed and before the surfaces have been contaminated with oil, grease, or soil.
- 3.9.2 All mechanical joint or push-on joint restraints, couplings, fittings, elbows, tees, crosses, interconnects, or valves with uncoated surfaces shall be protected with petrolatum tape as specified in the Cathodic Protection Specification.

3.10 Inspection and Testing During and After Application

- 3.10.1 The Inspector shall provide anchor profile measurements, ammeter reading indicating the electrical loading on the abrasive blasting wheel motor, type/percent mixture of the abrasive, and shall check the cleanliness of the abrasive blasting material.
- 3.10.2 The Inspector shall provide a written record of the quantity of coating material applied, the quantity of surface area covered, a pipe identification number, each coating product batch number, dew point temperature, surface temperature, ambient temperature, relative humidity, and names of applicators on a daily basis. The Inspector shall record the pressures and temperatures at which the coating material is being heated and delivered to the spray gun.
- 3.10.3 The Inspector shall provide wet film and dry film thickness readings, and results of the holiday testing, and shall note any discrepancies with the coating specifications.
- 3.10.4 Inspection Devices: The Contractor shall furnish, until final acceptance of such coatings, inspection devices in good working condition and calibrated for the detection of holidays and measurement of dry-film thicknesses of protective coatings. The Contractor shall provide the services of a trained operator of the holiday detection devices until the final acceptance of such coatings.
- 3.10.5 Holiday Testing: The Contractor shall holiday test all coated ferrous surfaces exposed to soil and severe service environments in the presence of the Inspector. After the specified coating has set hard to the touch, the Contractor shall test the coated surfaces for visual pinholes and sparking holidays using a high-voltage spark tester according to NACE SP0188. Areas which contain visual pinholes and sparking holidays shall be marked, repaired or recoated, and retested in accordance with the coating manufacturer's printed instructions. The electrode movement over the coating surface shall be continuous and shall proceed in a systematic manner, which ensures 100% coverage of the coated surfaces.
- 3.10.5.1 Coatings with DFT Exceeding 20 Mils: Pulse-type holiday detector, such as Tinker & Rasor Model AP-W, D.E. Stearns Co. Model 14/20, or equal, shall be used. Holiday testing shall be conducted with a new 12-inch or 18-inch wide wire brush electrode attached to the unit.

3.10.5.2 Induron Ceramawrap Coating: Low voltage-capable pulse type holiday detector such as Tinker & Razor Model AP-W, Elcometer 236 DC, or equal, shall be used at a setting of 2,000 Volts. Holiday testing shall be conducted with a new or clean 12-inch or 18-inch wire brush electrode.

3.10.6 Film Thickness Testing: On ferrous metals, the dry film coating thickness shall be measured in accordance with the SSPC PA2, Determining Profile Compliance, using an electromagnetic-type Type 2 dry film thickness gauge. The instruments shall have the capability of measuring 50% over the specified coating thickness and shall produce an actual reading and shall not be estimated. No measurements shall be made until at least 8 hours after application of the coating. The following instruments are acceptable:

3.10.6.1 Ferrous and Non Ferrous Surfaces

3.10.6.1.1 Wet – Notched gauge per ASTM D4414 or approved equal.

3.10.6.1.2 Dry – Elcometer Model 456, PosiTector 6000, Fischer MMS DFT, or equal.

3.10.7 Surface Profile: 30% of the pipe sections shall have the surface profile tested. The surface profile shall be tested with the use of Press-o-Film as manufactured by Testex or other NACE SP0287 approved equal, at locations to be determined by the Inspector. The replica tape thickness shall be measured using a dial micrometer manufactured by Testex or other ASTM D4417 Type C approved equal. For each test area, three replica tape tests shall be performed within a single test area 12 inches in diameter. For each test area, the three replica tape thickness values shall be recorded and must be within 10% of the coating manufacturer's recommended profile.

3.11 Handling, Transportation, and Storage

3.11.1 Coated pipe shall not be shipped or installed until coating has developed full adhesion and cure.

3.11.2 During coating application, storage, loading, transportation, unloading, laying and installation, the handler shall take precaution to not damage the coating. Padding shall be installed on surfaces of forklift equipment that comes in contact with the pipe.

3.11.3 When transporting multiple stacks of pipe, padded bolsters between each layer of pipe and heavy duty padding under the load tie-downs shall be installed. Bolsters shall be curved to fit the outside of the pipe and 12 inches wide. All pipe contact locations shall be heavily padded with carpet, HDPE padding, or other durable material when shipping to the project location and from the shop coating application location to the job site.

3.11.4 Dragging or skidding of pipe on grade or in trench will not be permitted.

3.11.5 The pipe shall not be laid on asphalt without suitable padding at all contact points.

3.11.6 Metal chains, wire cables, clam shell bucket, or excavator bucket in contact with the exterior of the pipe or appurtenances without padding shall not be used to lift or move the pipe.

- 3.11.7 The coated pipe shall be inspected by the Contractor at the job site for damage prior to laying down the pipe in the trench. Damage to the coating as defined in Section 3.12, shall be repaired in accordance with the manufacturer's recommendations to the satisfaction of BWS. If the damage is widespread and is more than 5% of the total surface area of the pipe section, the lining shall be removed by abrasive blasting and recoated.

3.12 Shop and Field Repairs

- 3.12.1 If an area is found to have bubbles, blisters, insufficient film thickness, visual or sparking holidays, or other deficiencies; then the Contractor shall abrade, clean, and topcoat the coated surface per the manufacturer's mixing recommendations and these Specifications. The abraded area and repair coating shall overlap the surrounding coated area by 3 to 6 inches, depending on the size of the defect or field repair. Work shall be free of bubbles, blisters, visual or sparking holidays, and discoloration.
- 3.12.2 Damaged shop coating that exposes the metal substrate greater than 1 inch in diameter or length shall be cleaned in accordance with SSPC SP11 using an MBX Bristleblaster, or equivalent, and in accordance with the manufacturer's recommendations.

3.13 Curing of Coatings

- 3.13.1 If the coating exhibits delamination, blisters, or tackiness after the manufacturer's recommended cure time, the Inspector shall conduct a Solvent Rub Test in accordance with ASTM D5402. The test area shall be evaluated for appearance, hardness, or any color transfer to the cloth. If there is no change to the coating after the test, it will be considered cured. If there is color transfer to a cloth, the affected areas shall be removed and recoated at the Contractor's expense.
- 3.13.2 If the coating exhibits softness, blisters, or tackiness after the manufacturer's recommended cure time, the Inspector shall conduct Shore D Hardness Testing per ASTM D2240. In order to consider the coating cured and properly mixed, it must meet the manufacturer's recommended Shore D Durometer requirement for the specified product. If the hardness result does not meet the requirement, the affected areas shall be removed and recoated at the Contractor's expense.
- 3.13.3 The Contractor shall provide curing conditions in accordance with the conditions recommended by the coating material manufacturer or by this Section, whichever is the highest requirement, prior to placing the completed coating system into service.
- 3.13.4 In the case of enclosed areas, forced air ventilation, using heated air if necessary, may be required until the coatings have fully cured.

3.14 Coating System Schedules for Ductile Iron Pipe

- 3.14.1 One of the following 100% solids polyurethanes, 100% solids epoxy, or approved equal, shall be used to coat the exterior surfaces of pipe exposed to soil and groundwater.
- 3.14.2 Any deviations to the following schedule shall be submitted 10 business days in advance and shall be approved by BWS prior its application. Unapproved materials applied prior to approval by BWS shall be removed at the sole expense of the Contractor.

Substrate	Surface Preparation	Coating System No.
Ductile Iron Pipe Exterior	NAPF-500-03-04 with a 3 mil surface profile minimum	P100 or E100
Ductile Iron and Cast Iron Fittings, Elbows, Tees, Crosses, Wyes and other metal appurtenances	NAPF-500-03-05 Blast Clean #1 with a 3 mil surface profile minimum	P100 or E100

BOARD OF WATER SUPPLY

CITY AND COUNTY OF HONOLULU
630 SOUTH BERETANIA STREET
HONOLULU, HI 96843
www.boardofwatersupply.com



July 29, 2019

KIRK CALDWELL, MAYOR

BRYAN P. ANDAYA, Chair
KAPUA SPROAT, Vice Chair
KAY C. MATSUI
RAY C. SOON
MAX J. SWORD

ROSS S. SASAMURA, Ex-Officio
JADE T. BUTAY, Ex-Officio

ERNEST Y. W. LAU, P.E.
Manager and Chief Engineer

ELLEN E. KITAMURA, P.E.
Deputy Manager and Chief Engineer

TO: WHOM IT MAY CONCERN

FROM: ERNEST Y. W. LAU, P.E., MANAGER AND CHIEF ENGINEER
BOARD OF WATER SUPPLY

SUBJECT: 2002 WATER SYSTEM STANDARDS AMENDMENT

For Oahu Only, the 2002 Water System Standards shall be amended as follows:

- DIVISION 100 – PLANNING, Section 102 – Mains:
 - Delete **Table 100-4 - TYPE AND CLASSES OF MAINS** and replace with the following table:

Table 100-4 - TYPES AND CLASSES OF MAINS (Revised 7/2019 - FOR OAHU ONLY)		
Island	Ductile Iron AWWA C151	PVC AWWA C900
Oahu	1, 4, 5	2, 3, 5

- 1 - Ductile Iron pipe is required for mains 4-inch through 42-inch in diameter, class 53, zinc coated, except as identified in item 2 and 3 below. See Water System External Corrosion Control Standards as applicable to the project.
- 2 - PVC pipe is required if one of the following conditions are present and the maximum static pressure does not exceed 100 psi or approved by the Manager:
 - The invert of the pipe is at mean sea level elevation of +5-feet or lower.
 - The average soil resistivity for the project is less than 500 ohm-cm. Average soil resistivity shall be based on laboratory soil resistivity testing performed on soil samples taken along the main alignment at a maximum of 300 feet on center, and at the invert of the main.

WHOM IT MAY CONCERN

July 29, 2019

Page 2

- 3 - Mains 4-inch through 12-inch in diameter, DR14 only.
 - 4 - Ductile Iron Pipe shall be required for all water system piping installed in petroleum contaminated soil or petroleum contaminated groundwater. All gaskets shall be made of Nitrile elastomer or approved equal for use in petroleum conditions. See Water System External Corrosion Control Standards as applicable to the project.
 - 5 - For Mains installed in other types of contaminated soil or other types of contaminated groundwater, the type of main shall be as directed by the Manager.
- **DIVISION 200 – MATERIALS, Section 209 – Premolded Filler, Crushed Rock, Pipe Cushion, Backfill Material and Bricks:**
 - Add the following requirement in **Section 209.02 Pipe Cushion:**

Pipe cushion for PVC pipes shall be natural sand or manufactured sand only.

All construction plans received by the Board of Water Supply after September 30, 2019, shall comply with the above amendments.

If you have any questions, please contact Michael Domion, Support Branch Head, Capital Projects Division, at 748-5740 or mdomion@hbws.org.

BOARD OF WATER SUPPLY

CITY AND COUNTY OF HONOLULU
630 SOUTH BERETANIA STREET
HONOLULU, HI 96843
www.boardofwatersupply.com



August 2, 2018

KIRK CALDWELL, MAYOR

BRYAN P. ANDAYA, Chair
KAPUA SPROAT, Vice Chair
DAVID C. HULIHEE
KAY C. MATSUI
RAY C. SOON

ROSS S. SASAMURA, Ex-Officio
JADE T. BUTAY, Ex-Officio

ERNEST Y. W. LAU, P.E.
Manager and Chief Engineer

ELLEN E. KITAMURA, P.E.
Deputy Manager and Chief Engineer

TO: WHOM IT MAY CONCERN

FROM: ERNEST Y. W. LAU, P.E., MANAGER AND CHIEF ENGINEER
BOARD OF WATER SUPPLY

SUBJECT: 2002 WATER SYSTEM STANDARD AMENDMENTS

For Oahu only, the 2002 Water System Standards shall be amended as follows:

DIVISION 100 – PLANNING, Section 105 STRUCTURES

1. Delete section 105.08 PERIMETER FENCE and replace with:

Provide an 8-foot high, expanded metal fence around perimeter of property and gate for driveway, and security devices as specified by the Department.

DIVISION 300 – CONSTRUCTION, Section 303 STRUCTURES

2. Add new sub-section 303.34 EXPANDED METAL FENCE AND GATE (attached).

All construction plans received by the Board of Water Supply after August 31, 2018, shall comply with the above amendment.

If you have any questions, please contact Michael Domion, Support Branch Head, Capital Projects Division, at 748-5740.

Attachment

303.34 EXPANDED METAL FENCE AND GATE.

A. Description. The work shall consist of furnishing all material, labor, tools, equipment and incidentals required to install expanded metal fence, expanded metal gate, and all appurtenances in place complete, as shown on the plans and as specified in these Standards.

B. Material. All materials for the expanded metal fence work shall have a powder-coating finish consisting of an electro deposition pretreatment E-coat, a color coat, and top coated with a TGIC polyester powder. The color of the powder-coating shall be standard green.

1. Expanded Metal Mesh. Expanded metal mesh shall be hot-dipped galvanized carbon steel in accordance with ASTM A123. The expanded metal mesh shall be No. 9 gauge, standard type with a 3/4-inch size opening. The mesh shall have a strand width of 0.15-inches, strand thickness of 0.134-inches, SWD of 0.923-inches, LWD of 2.0-inches, and a percent open area of 68%.

Expanded metal mesh shall be fabricated to 8-foot high panels. Width of the panels shall be maximized to meet post spacing requirements as shown on the plans and as recommended by the manufacturer.

2. Posts. All posts shall be Schedule 40 galvanized steel pipe. Galvanizing shall be in accordance with ASTM F1083-06 and sizes shall be as specified in Table 300-19:

Table 300-19 – EXPANDED METAL FENCE POST			
Type of Post	Nominal Diameter (in.)	Outside Diameter (in.)	Weight (lbs./lin. ft.)
Line post	2½	2.875	5.79
Gate, terminal, end, and corner post	3½	4.0	9.11
Gate frame	1½	1.9	2.72

All posts shall be provided at heights to accommodate the full height of the expanded metal mesh panels, concrete footings, specified security fencing wire, topography, and wind load requirements as shown on the plans or as recommended by the manufacturer.

All posts shall include pressed steel dome caps.

DIVISION 300 - CONSTRUCTION

3. Horizontal Rails. The expanded metal fence shall utilize three (3) horizontal rails (top, mid, and bottom) as part of the fence framework. Horizontal rails shall be hot-dipped galvanized No. 14 gauge, c-channel rails 1-5/8-inch x 13/16-inch with slotted holes, in accordance with ASTM A123, and attached with associated fittings. Welding shall not be permitted.

4. Fittings. All fittings used in connection with the installation of expanded metal fence and gate shall be hot-dipped galvanized No. 11 gauge, pressed steel with slotted holes, in accordance with ASTM A123. Expanded metal mesh fittings (bands, clamps, tensioners, etc.) shall be used to attach and secure expanded metal mesh-to-mesh and mesh-to-post components, and shall be sized to match the outside diameter of all line, gate, terminal, end, and corner posts.

All nuts and bolts shall be 5/16-inch x 2-inch stainless steel carriage bolts with breakaway nuts to maximize security and per manufacturer's recommendation.

5. Gate. Gate shall be expanded metal single or double leaf as called for on the plans. Gate frame shall be of welded construction in accordance with ASTM 900 and operate under the added weight of the expanded metal mesh and the effects of additional wind loading.

Expanded metal mesh panels shall be attached to the outside of the frame with associated fittings. Gate hinges shall be structurally capable of supporting each gate leaf and allow the gate to open and close without binding. The gate shall be furnished complete with special pivot type hinges, catch, stops, center rest and locking device for padlock. Gate shall be securely braced and trussed to prevent sagging as necessary.

6. Lock Opening. Lock opening shall be located immediately adjacent to the frame and approximately 4 feet above ground. The lock opening should measure approximately 4-inch x 4-inch and align with lock opening of adjacent gate or secured post. The lock opening shall have a framed edge that match approved fittings in material type and color. Chain and lock to be provided by BWS upon transition of ownership to BWS.

7. Security Fencing Wire. Either barbed wire or razor wire shall be installed at the top of the expanded metal fence and gate where called for on the plans or as directed by the Manager.

- a. Barbed wire shall be composed of 3 strands of No. 12-½ gauge wire with 4 point barbs spaced 5 inches apart and heavily galvanized.
- b. Razor wire shall be 18-inch long barb, wire-reinforced concertina with stainless steel strip and stainless steel core.

DIVISION 300 - CONSTRUCTION

8. Extension Arm. Post extension arms shall be used for supporting barbed wire and shall be formed from 0.090-inch steel sheet and hot dip galvanized. Arms for barbed wire shall be designed to extend at a 45° angle with lock to securely fasten strands of barbed wire equally spaced with top strand located 12 inches above the expanded metal mesh and 12 inches out from the fence line.

C. Installation. The ground along the fence line shall be properly graded on a straight grade unless otherwise noted on the plans. All obstructions and vegetation shall be removed on both sides of proposed fence alignment as necessary, for the proper installation of the new expanded metal fence and gate.

Installation and layout of the new expanded metal fence alignment shall be in accordance with the construction plans and approved by the Manager prior commencing work. The maximum clearance between the bottom of the fence and the ground surface shall be 4 inches. Post spacing shall allow for two expanded metal mesh panels per section and posts shall be located within the maximum spacing based on topography and wind load requirements as shown on the plans or as recommended by the manufacturer. Post spacing shall be determined by measurement parallel to the slope of the ground. All posts shall be placed plumb and set on center.

All posts shall be set in DWS 2500 concrete footings. Size of footings for the posts shall be as shown on the on the plans or as recommended by the manufacturer. Concrete shall be consolidated and crowned at the top to keep water from ponding on the post footing.

Install all horizontal rails level. Bottom rails shall be installed 3 to 6 inches above the bottom of the expanded metal mesh panels. Top rails shall be installed 3 to 6 inches from the top of the expanded metal mesh panels.

All posts, rails, and gate frames shall be covered with expanded metal mesh panels and shall fit flush on all sides allowing no open spaces between the expanded metal mesh. Expanded metal mesh panels shall overlap a minimum of three diamonds or three inches and be secured with appropriate fittings as recommended by the manufacturer.

The expanded metal mesh panels shall be attached and secured with various associated fittings as shown on the plans or as recommended by the manufacturer. All fittings shall be sized to match the outside diameter of all line, gate, terminal, end, and corner posts. Bands shall be used to attach all horizontal rails to line posts. C-clamps shall be used to attach the expanded metal mesh panels at each line post. Latch clamps shall lock into expanded metal mesh and through the horizontal rails and shall be placed every 12 to 15 inches along all horizontal rails. Clamp bars shall be used in pairs to join expanded metal mesh panels vertically between horizontal rails. End Tensioners shall be used to secure expanded metal mesh to the gate posts.

All expanded metal fence and gate components that have been damaged or repaired shall be touched-up with a cold galvanizing compound. Color shall match the powder-coating finish, standard green.

DIVISION 300 - CONSTRUCTION

D. Payment. Payment for EXPANDED METAL FENCE AND GATE (1) will be made at the respective Unit Price Bids or Lump Sum Bids, whichever is specified, or (2) will not be made directly but shall be included in the payment of which it is a part. In either case, such payment shall represent full compensation for furnishing all materials, labor, tools, equipment and incidentals, including excavation, grading and concrete required to complete the work.

Payment quantity under Unit Price Bid shall be the actual number of linear feet of expanded metal fence inclusive of mesh, posts, horizontal rails, fittings, excavation and backfill, concrete footings, fencing wire and other incidentals constructed in place complete from the outside of end posts exclusive of the expanded metal gate, and the actual number of expanded metal gates constructed in place complete.

BOARD OF WATER SUPPLY

CITY AND COUNTY OF HONOLULU
630 SOUTH BERETANIA STREET
HONOLULU, HI 96843
www.boardofwatersupply.com



November 17, 2016

KIRK CALDWELL, MAYOR

BRYAN P. ANDAYA, Chair
ADAM C. WONG, Vice Chair
DAVID C. HULIHEE
KAPUA SPROAT
KAY C. MATSUI

ROSS S. SASAMURA, Ex-Officio
FORD N. FUCHIGAMI, Ex-Officio

ERNEST Y. W. LAU, P.E.
Manager and Chief Engineer

ELLEN E. KITAMURA, P.E.
Deputy Manager and Chief Engineer *Ellen Kitamura*

TO: WHOM IT MAY CONCERN

FROM: ERNEST Y. W. LAU, P.E., MANAGER AND CHIEF ENGINEER *EYL*
BOARD OF WATER SUPPLY

SUBJECT: 2002 WATER SYSTEM STANDARDS AMENDMENT

For Oahu only, the 2002 Water System Standards shall be amended as follows:

DIVISION 200 – MATERIALS, Section 202 – Ductile Iron Pipe, Fittings, and Appurtenances:

1. Delete **Section 202.01.B. Polyethylene Encasement** and replace with the following:

B. Polyethylene Encasement. Unless otherwise specified, all ductile iron pipes, valves, and fittings shall be encased in two layers of 8 mil minimum thickness polyethylene material in accordance with ANSI A-21.5 and AWWA C105. The polyethylene encasement film shall be manufactured from virgin polyethylene and shall consist of three layers of co-extruded linear low density polyethylene (LLDPE), fused into a single thickness of not less than eight mils. The inside surface of the polyethylene wrap to be in contact with the pipe exterior shall be infused with a blend of an antimicrobial to mitigate microbiologically influenced corrosion and a volatile corrosion inhibitor to control galvanic corrosion. Polyethylene material shall have permanent markings per AWWA C105.

Copper service laterals shall be encased with polyethylene wrap (3 feet minimum) from the connection to ductile iron pipes as shown on the Standard Details.

2. Delete **Section 202.01E. Exterior Coating** and replace with the following:

E. Exterior Coating. The exterior of all ductile pipe shall be coated with a layer of arc-sprayed zinc per ISO 8179-1. The mass of the zinc applied shall be a minimum of 200g/m² of pipe surface area. After the zinc coating, the pipe shall be given a finishing layer of bituminous paint topcoat compatible with zinc, approximately 1 mil thick.

All ductile iron fittings, and special castings shall be coated on the exterior surfaces with a bituminous coating approximately 1 mil thick. The finished coating shall be continuous, smooth, neither brittle when cold nor sticky when exposed to the sun and shall be strongly adherent to the pipe. Surfaces shall be clean and dry, free from all grease, oil, sand, and other foreign materials when painted.

**DIVISION 500 – WATER SYSTEM EXTERNAL CORROSION CONTROL
STANDARDS, VOLUME 3 DATED 1991:**

3. The design of the cathodic protection system shall incorporate zinc coated ductile iron pipe with two layers of polyethylene encasement in accordance to the above amended Section 202 – Ductile Iron Pipe, Fittings, and Appurtenances. The zinc coated ductile iron pipe with two layers of polyethylene encasement shall be in lieu of the bonded tape coating.

All construction plans received by the Board of Water Supply after December 30, 2016, shall comply with the above amendment.

If you have any questions, please contact Michael Domion, Support Branch Head, Capital Projects Division, at 748-5740.

cc: Hawaii, Kauai and Maui Water Departments

MP

BOARD OF WATER SUPPLY

CITY AND COUNTY OF HONOLULU
630 SOUTH BERETANIA STREET
HONOLULU, HI 96843



May 6, 2016

KIRK CALDWELL, MAYOR

DUANE R. MIYASHIRO, Chair
ADAM C. WONG, Vice Chair
DAVID C. HULIHEE
KAPUA SPROAT
BRYAN P. ANDAYA

ROSS S. SASAMURA, Ex-Officio
FORD N. FUCHIGAMI, Ex-Officio

ERNEST Y. W. LAU, P.E.
Manager and Chief Engineer

ELLEN E. KITAMURA, P.E.
Deputy Manager and Chief Engineer 

Mr. Blake Kidd
The Ford Meter Box Company, Inc.
775 Manchester Avenue
P.O. Box 443
Wabash, Indiana 46992-0443

Dear Mr. Kidd:

Subject: Your Letter Dated December 20, 2013, Regarding Request for Inclusion into the Approved Materials List

The Board of Water Supply approves the following Ford Meter Box products for inclusion into the Approved Materials List of the Water System Standards **for Oahu only**:

1. FB400 Ball Corporation Stop
2. B11 Ball Valve
3. Pack Joint Coupling – C14 (female IPT x Pack Joint), C84 (male IPT x Pack Joint) and C44 (Pack Joint x Pack Joint)

Further evaluation is still needed for the Ford Meter Box Double Strap Brass Saddle 202B.

If you have any questions, please contact Michael Domion, Support Branch Head, Capital Projects Division, at (808)748-5740.

Very truly yours,



ERNEST Y. W. LAU, P. E.
Manager and Chief Engineer

cc: Kauai, Maui and Hawaii Department of Water Supply

FORD The Ford Meter Box Company, Inc.

RECEIVED
BOARD OF WATER SUPPLY
Phone: 206-563-3171 • Fax 800-826-3487 • Overseas Fax: 260-563-0167 • www.fordmeterbox.com

mgp
Rep
CP

2013 DEC 26 A 11: 05
Mr. Ernest Lau, PE
Manager & Chief Engineer
Honolulu Board of Water Supply
630 S. Beretania St.
Honolulu, HI 96843

December 20, 2013

2013 DEC 26 P 4: 10

BWS - ENGINEERING

Dear Mr. Lau,

Ford Meter Box respectfully submits the following items for inclusion into The Board of Water's Approved Materials list. The 202B double strap bronze saddle, the FB400 ball corporation stop, the B11 style ball valve and pack joint adapters. All of the fittings (with the exception of the saddles) are manufactured of ASTM C89833 "no lead" brass in compliance with the Safe Drinking Water Act. The products with this alloy shall meet NSF/ANSI Standard 61 and/or NSF/ANSI Standard 372 as applicable. The bronze saddles continue to be manufactured from traditional waterworks red brass ASTM C83600.

The 202B saddle is designed with built-in flexibility to cover asbestos-cement and/or cast iron pipe along with ductile iron pipe. The straps are high quality silicon bronze flattened to provide a wide bearing surface against the pipe. The large EPDM rubber gasket is grooved to conform to the pipe surface and bonded in place for easy installation. It is available with both AWWA/CC taps and IP taps.

The FB400 ball corporation stop is designed to reduce hard turning and temporary weeping that is sometimes encountered with high pressure tests on standard plug type corporation stops. The Ford ball corporation stop is designed to withstand 300 psi.

The B11 style ball valve is designed to be watertight in either direction and features both female iron pipe inlets and outlets. As with the ball corporation stop the ball valve will also withstand 300 psi.

The Ford Meter Box line of pack joint fittings are designed with machined grooves in the clamping section to provide superior restraint on copper and plastic tubing. The gaskets are made from EPDM and beveled for a watertight seal on the tubing. We are submitting on the male iron pipe by compression (C84-xx-NL), the female iron pipe by compression (C14-xx-NL) and the compression by compression (C44-xx-NL) in all sizes.

I have enclosed submittals for all of the products. Please contact me for samples or additional information.

Sincerely,

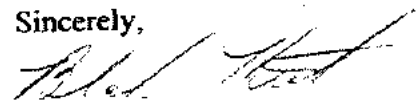

Blake Kidd
District Manager
THE FORD METER BOX COMPANY, Inc.
enclosures

SUBMITTAL INFORMATION

Ballcorp Corporation Stops - (FB400-4-NL style)

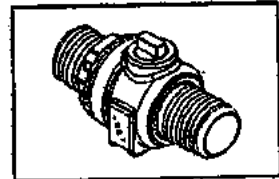

AWWA/CC TAPER THREAD INLET BY MALE IRON PIPE OUTLET

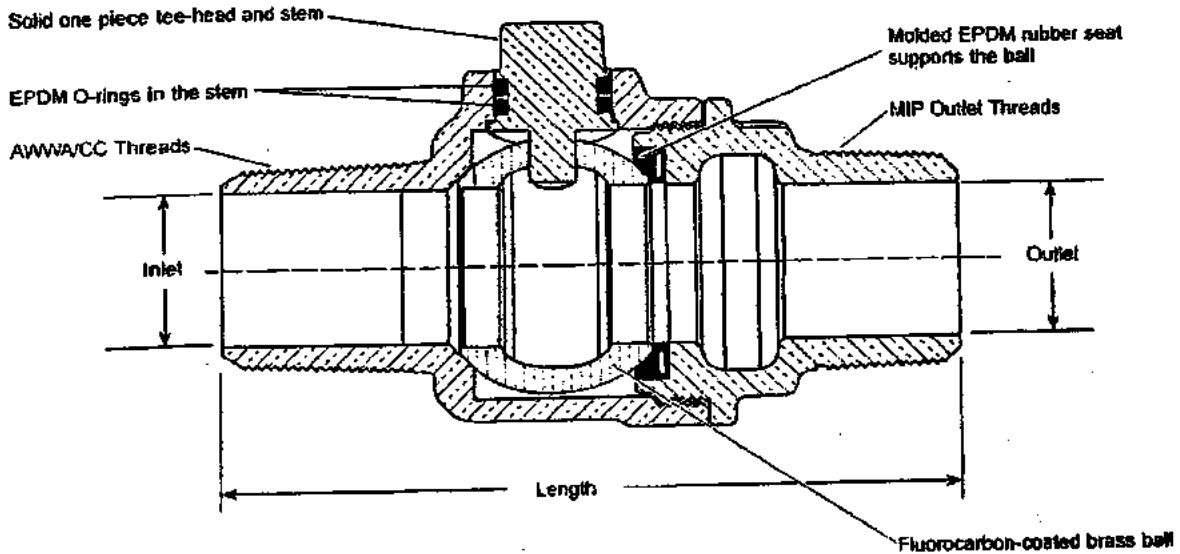

VALVE SIZE	INLET SIZE	OUTLET SIZE	VALVE LENGTH	BODY OUTLET THREADS	APPROX. Wt. Lbs	PART NUMBER	✓ SUBMITTED ITEM(S)
1"	1"	1"	4-33/64"	1" MIP	1.7	FB400-4-NL	

FEATURES

- All brass that comes in contact with potable water conforms to AWWA Standard C800 (UNS NO C89833)
- The product has the letters "NL" cast into the main body for proper identification
- UL Classified to ANSI/NSF Standard 61 and Standard 61 Annex G (NSF/ANSI 372)
- Brass components that do not come in contact with potable water conform to AWWA Standard C800 (ASTM B-62 and ASTM B-584, UNS NO C83600 - 85-5-5-5)
- Ends are integral or secured with adhesive to prevent unintentional disassembly
- 300 PSI working pressure

The Ford Meter Box Company considers the information in this submittal form to be correct at the time of publication. Item and option availability, including specifications, are subject to change without notice. Please verify that your product information is current.



The Ford Meter Box Company, Inc.
 P.O. Box 443, Wabash, Indiana U.S.A. 46992-0443
 Phone: 260-563-3171 / Fax: 800-826-3487
 Overseas Fax: 260-563-0167
<http://www.fordmeterbox.com>

C2/04/13

Submitted By:

SUBMITTAL INFORMATION

Ballcorp Corporation Stops - (FB400-6-NL style)

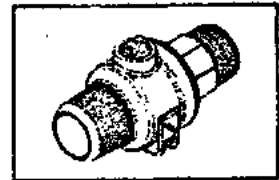

AWWA/CC TAPER THREAD INLET BY MALE IRON PIPE OUTLET

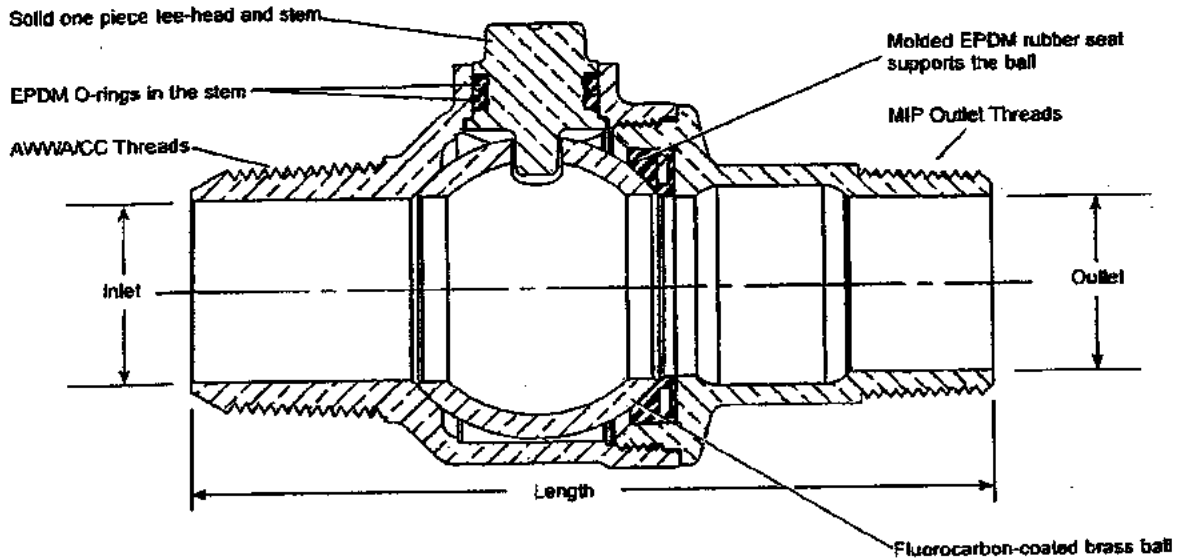

VALVE SIZE	INLET SIZE	OUTLET SIZE	VALVE LENGTH	BODY OUTLET THREADS	APPROX. WT. LBS	PART NUMBER	✓ SUBMITTED ITEM(S)
1-1/2"	1-1/2"	1-1/2"	6-9/16"	1-1/2" MIP	4.7	FB400-6-NL	

FEATURES

- All brass that comes in contact with potable water conforms to AWWA Standard C800 (UNS NO C89833)
- The product has the letters "NL" cast into the main body for proper identification
- UL Classified to ANSI/NSF Standard 61 and Standard 61 Annex G (NSF/ANSI 372)
- Brass components that do not come in contact with potable water conform to AWWA Standard C800 (ASTM B-62 and ASTM B-584, UNS NO C83600 - 85-5-5-5)
- Ends are integral or secured with adhesive to prevent unintentional disassembly
- 300 PSI working pressure

The Ford Meter Box Company considers the information in this submittal form to be correct at the time of publication. Item and option availability, including specifications, are subject to change without notice. Please verify that your product information is current.



The Ford Meter Box Company, Inc.
 P.O. Box 443, Wabash, Indiana U.S.A. 46992-0443
 Phone: 260-563-3171 / Fax: 800-826-3487
 Overseas Fax: 260-563-0167
<http://www.fordmeterbox.com>

07/02/13

Submitted By:

SUBMITTAL INFORMATION

Ballcorp Corporation Stops - (FB400-7-NL style)

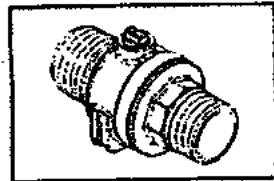

AWWA/CC TAPER THREAD INLET BY MALE IRON PIPE OUTLET

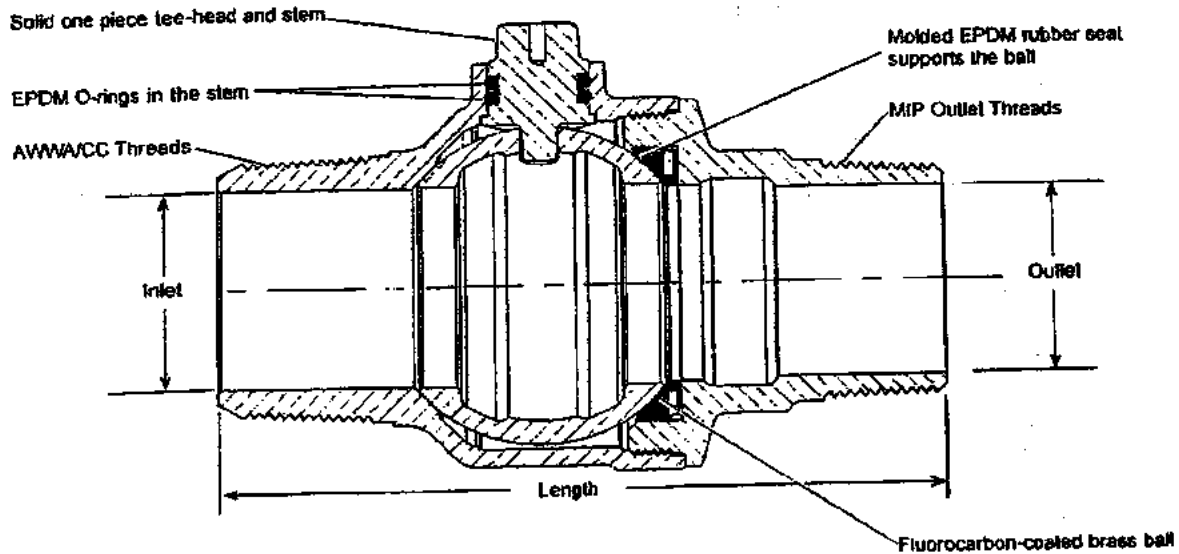

VALVE SIZE	INLET SIZE	OUTLET SIZE	VALVE LENGTH	BODY OUTLET THREADS	APPROX. Wt. LBS	PART NUMBER	✓ SUBMITTED (ITEMS)
2"	2"	2"	7-5/16"	2" MIP	7.2	FB400-7-NL	

FEATURES

- All brass that comes in contact with potable water conforms to AWWA Standard C800 (UNS NO C89633)
- The product has the letters "NL" cast into the main body for proper identification
- UL Classified to ANSI/NSF Standard 61 and Standard 61 Annex G (NSF/ANSI 372)
- Brass components that do not come in contact with potable water conform to AWWA Standard C800 (ASTM B-62 and ASTM B-584, UNS NO C83600 - 85-5-5-5)
- Ends are integral or secured with adhesive to prevent unintentional disassembly
- 300 PSI working pressure

The Ford Meter Box Company considers the information in this submittal form to be correct at the time of publication. Item and option availability, including specifications, are subject to change without notice. Please verify that your product information is current.



The Ford Meter Box Company, Inc.
 P.O. Box 443, Wabash, Indiana U.S.A. 46992-0443
 Phone: 260-563-3171 / Fax: 800-826-3487
 Overseas Fax: 260-563-0167
<http://www.fordmeterbox.com>

02/04/13

Submitted By

SUBMITTAL INFORMATION

Ball Valve Curb Stop - (B11-xxx-NL style)

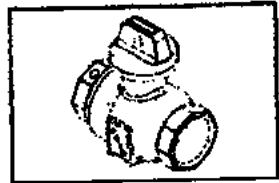

FEMALE IRON PIPE THREAD INLET BY FEMALE IRON PIPE THREAD OUTLET

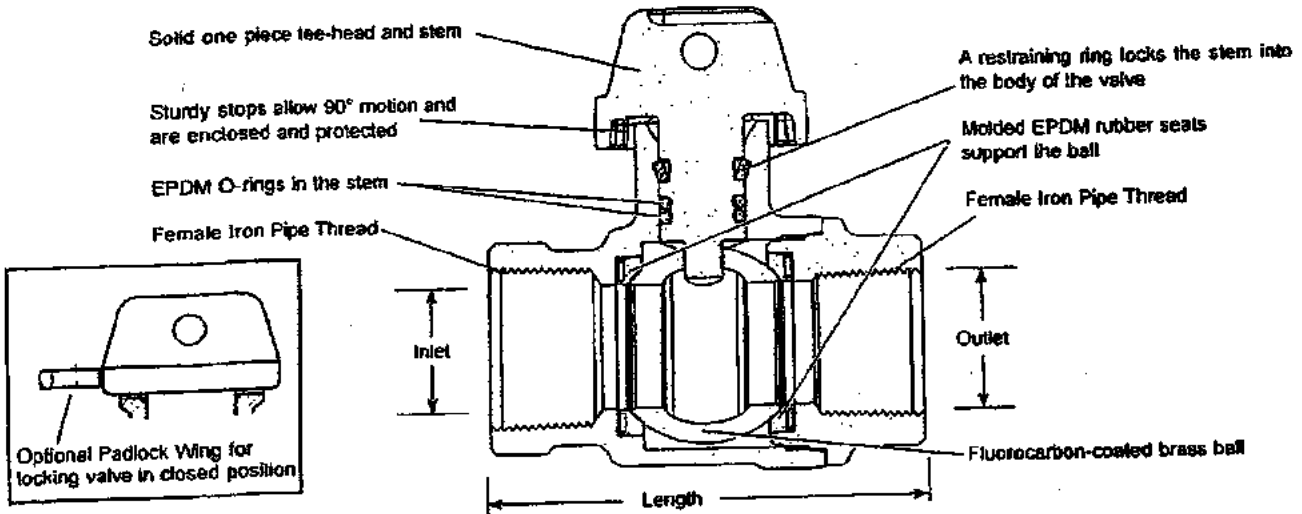

VALVE SIZE	INLET SIZE	OUTLET SIZE	LENGTH	APPROX. WT. LBS	PART NUMBER	✓ SUBMITTED ITEM(S)
3/4"	3/4"	3/4"	3-1/64"	1.5	B11-333-NL	
1"	1"	1"	3-7/16"	2.0	B11-444-NL	

FEATURES

- All brass that comes in contact with potable water conforms to AWWA Standard C800 (UNS NO C89B33)
- The product has the letters "NL" cast into the main body for proper identification
- UL Classified to ANSI/NSF Standard 61 and Standard 61 Annex G (NSF/ANSI 372)
- Brass components that do not come in contact with potable water conform to AWWA Standard C800 (ASTM B-62 and ASTM B-584, UNS NO C83600 - 85-5-5-5)
- Valve is non-directional and is watertight with flow in either direction
- Ends are integral or secured with adhesive to prevent unintentional disassembly
- Hole for attaching curb box rod or handle is provided in tee-head
- 300 PSI working pressure

Optional Padlock Wing for locking valve in closed position. Add "W" to part number
 Optional full 360° tee-head rotation. Add "R" to part number

The Ford Meter Box Company considers the information in this submittal form to be correct at the time of publication. Item and option availability, including specifications, are subject to change without notice. Please verify that your product information is current.



The Ford Meter Box Company, Inc.
 P.O. Box 443, Wabash, Indiana U.S.A. 46992-0443
 Phone: 260-563-3171 / Fax: 800-826-3487
 Overseas Fax: 260-563-0167
<http://www.fordmeterbox.com>

07/21/13

Submitted By:

SUBMITTAL INFORMATION

Ball Valve Curb Stop - (B11-xxx-NL style)



FEMALE IRON PIPE THREAD INLET BY FEMALE IRON PIPE THREAD OUTLET

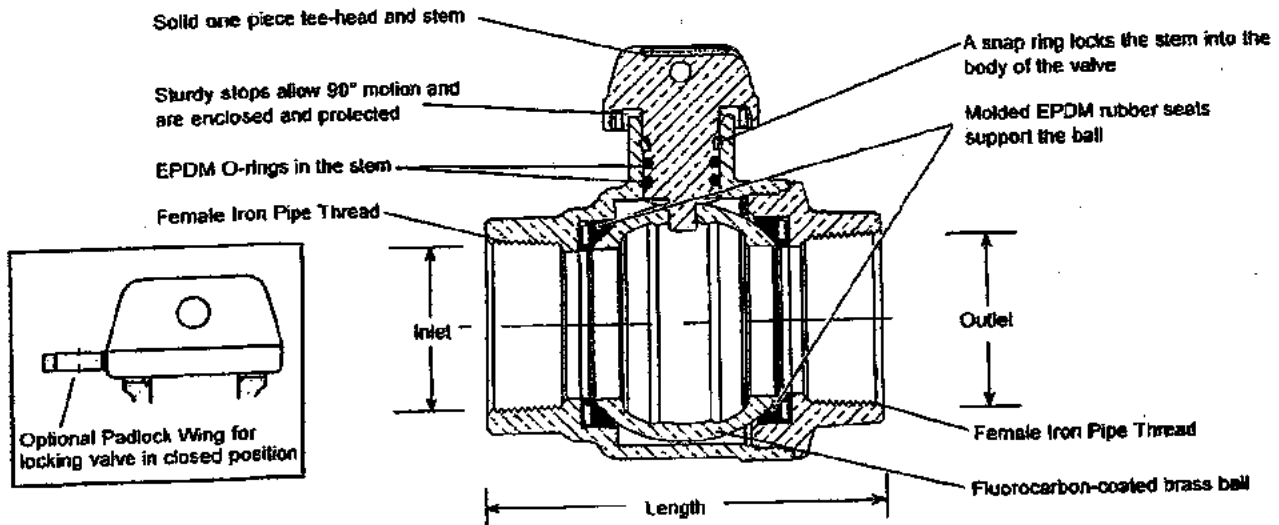

VALVE SIZE	INLET SIZE	OUTLET SIZE	LENGTH	APPROX. Wt. LBS	PART NUMBER	✓ SUBMITTED ITEM(S)
1-1/2"	1-1/2"	1-1/2"	4-15/32"	4.8	B11-666-NL	
2"	2"	2"	5-1/4"	7.2	B11-777-NL	

FEATURES

- All brass that comes in contact with potable water conforms to AWWA Standard C800 (UNS NO C89833)
- The product has the letters "NL" cast into the main body for proper identification
- UL Classified to ANSI/NSF Standard 61 and Standard 61 Annex G (NSF/ANSI 372)
- Brass components that do not come in contact with potable water conform to AWWA Standard C800 (ASTM B-62 and ASTM B-584, UNS NO C83600 - 85-5-5-5)
- Valve is non-directional and is watertight with flow in either direction
- Ends are integral or secured with adhesive to prevent unintentional disassembly
- Hole for attaching curb box rod or handle is provided in tee-head
- 300 PSI working pressure

Optional Padlock Wing for locking valve in closed position. Add "W" to part number
 Optional full 360° tee-head rotation. Add "R" to part number

The Ford Meter Box Company considers the information in this submittal form to be correct at the time of publication. Item and option availability, including specifications, are subject to change without notice. Please verify that your product information is current.



The Ford Meter Box Company, Inc.
 P.O. Box 443, Wabash, Indiana U.S.A. 46992-0443
 Phone: 260-563-3171 / Fax: 800-826-3487
 Overseas Fax: 260-563-0167
<http://www.fordmeterbox.com>

02/14/13

Submitted By:

SUBMITTAL INFORMATION

Pack Joint Coupling - (C14-xx-NL style)



FEMALE IRON PIPE THREAD BY PACK JOINT FOR COPPER OR PLASTIC TUBING (CTS)

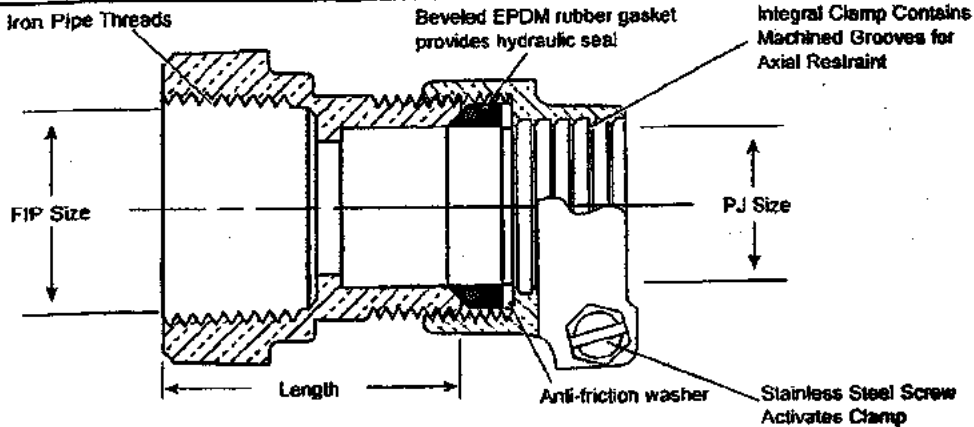

DESCRIPTION		LENGTH	APPROX. Wt. LBS	PART NUMBER	✓ SUBMITTED ITEM(S)
FEMALE IRON PIPE	P.J. FOR CTS				
1/2"	1/2"	1-8/16"	.4	C14-11-NL	
1/2"	3/4"	1-5/16"	.5	C14-13-NL	
3/4"	1/2"	1-3/4"	.8	C14-31-NL	
3/4"	3/4"	1-5/16"	.6	C14-33-NL	
3/4"	1"	1-3/4"	.7	C14-34-NL	
3/4"	1-1/4"	1-7/8"	1.3	C14-35-NL	
1"	3/4"	1-13/16"	.7	C14-43-NL	
1"	1"	1-7/8"	.9	C14-44-NL	
1"	1-1/4"	1-13/16"	1.1	C14-45-NL	
1-1/4"	1"	1-13/16"	.9	C14-54-NL	
1-1/4"	1-1/4"	1-15/16"	1.4	C14-55-NL	
1-1/4"	1-1/2"	2-1/8"	1.7	C14-56-NL	
1-1/2"	1-1/2"	2-7/16"	2.3	C14-66-NL	
1-1/2"	2"	2-1/2"	2.6	C14-67-NL	
2"	1-1/2"	3-1/4"	2.5	C14-76-NL	
2"	2"	2-1/4"	2.8	C14-77-NL	

Note: Ford recommends insert stiffeners when using plastic pipe or tubing.



FEATURES

- All brass that comes in contact with potable water conforms to AWWA Standard C800 (UNS NO C89833)
- Brass components that do not come in contact with potable water conform to AWWA Standard C800 (ASTM B-62 and ASTM B-584, UNS NO C83600 - 85-5-5-5)
- Sleeve design provides hexagonal wrench flats for proper installation
- The product has the letters "NL" cast into the main body for proper identification
- UL Classified to ANSI/NSF Standard 61 and Annex G

The Ford Meter Box Company considers the information in this submittal form to be correct at the time of publication. Item and option availability, including specifications, are subject to change without notice. Please verify that your product information is current.



The Ford Meter Box Company, Inc.
 P.O. Box 443, Wabash, Indiana U.S.A. 46992-0443
 Phone: 260-563-3171 / Fax: 800-826-3487
 Overseas Fax: 260-563-0167
<http://www.fordmeterbox.com>

12/06/11

Submitted By:

SUBMITTAL INFORMATION

Pack Joint Coupling - (C84-xx-NL style)



MALE IRON PIPE BY PACK JOINT FOR COPPER OR PLASTIC TUBING (CTS)

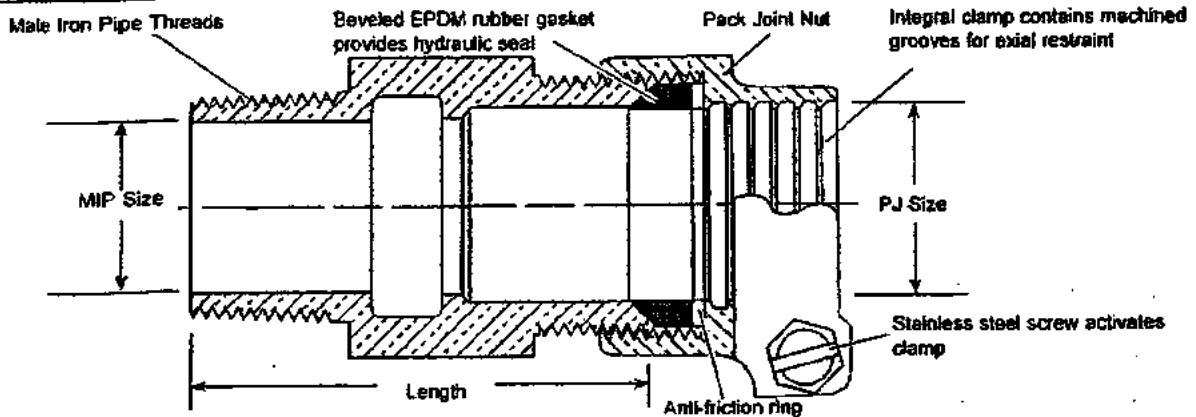

DESCRIPTION		LENGTH	APPROX. Wt. LBS	PART NUMBER	3 SUBMITTED ITEM(S)
MALE IRON PIPE	P.J. FOR CTS				
1/2"	1/2"	2"	.5	C84-11-NL	
1/2"	5/8"	2-1/16"	.8	C84-12-NL	
1/2"	3/4"	2-1/16"	.8	C84-13-NL	
3/4"	1/2"	2"	.8	C84-31-NL	
3/4"	5/8"	-	.7	C84-32-NL	
3/4"	3/4"	2-1/4"	.6	C84-33-NL	
3/4"	1"	2-3/8"	.7	C84-34-NL	
1"	5/8"	-	-	C84-42-NL	
1"	3/4"	2-3/8"	.7	C84-43-NL	
1"	1"	2-9/16"	.8	C84-44-NL	
1"	1-1/4"	2-1/2"	1.2	C84-45-NL	
1"	1-1/2"	2-9/16"	1.8	C84-46-NL	
1-1/4"	1"	2-9/16"	1.4	C84-54-NL	
1-1/4"	1-1/4"	2-9/16"	1.4	C84-55-NL	
1-1/4"	1-1/2"	3-1/4"	1.8	C84-56-NL	
1-1/2"	1-1/2"	3-1/4"	2.0	C84-66-NL	
1-1/2"	2"	2-15/16"	2.6	C84-67-NL	
2"	2"	3-1/4"	3.1	C84-77-NL	



Note: Ford recommends using insert stiffeners with plastic pipe or tubing.

FEATURES

- All brass that comes in contact with potable water conforms to AWWA Standard C800 (UNS NO C89833)
- Brass components that do not come in contact with potable water conform to AWWA Standard C800 (ASTM B-62 and ASTM B-584, UNS NO C83600 - 85-5-5-5)
- Sleeve design provides hexagonal wrench flats for proper installation
- The product has the letters "NL" cast into the main body for proper identification
- UL Classified to ANSI/NSF Standard 61 and Annex G

The Ford Meter Box Company considers the information in this submittal form to be correct at the time of publication. Item and option availability, including specifications, are subject to change without notice. Please verify that your product information is current.



The Ford Meter Box Company, Inc.
P.O. Box 443, Wabash, Indiana U.S.A. 46992-0443
Phone: 260-563-3171 / Fax: 800-826-3487
Overseas Fax: 260-563-0167
<http://www.fordmeterbox.com>

12/06/11

Submitted By:

SUBMITTAL INFORMATION

Pack Joint Coupling - (C44-xx-NL style)

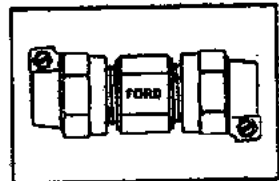

PACK JOINT FOR COPPER OR PLASTIC TUBING (CTS) BOTH ENDS

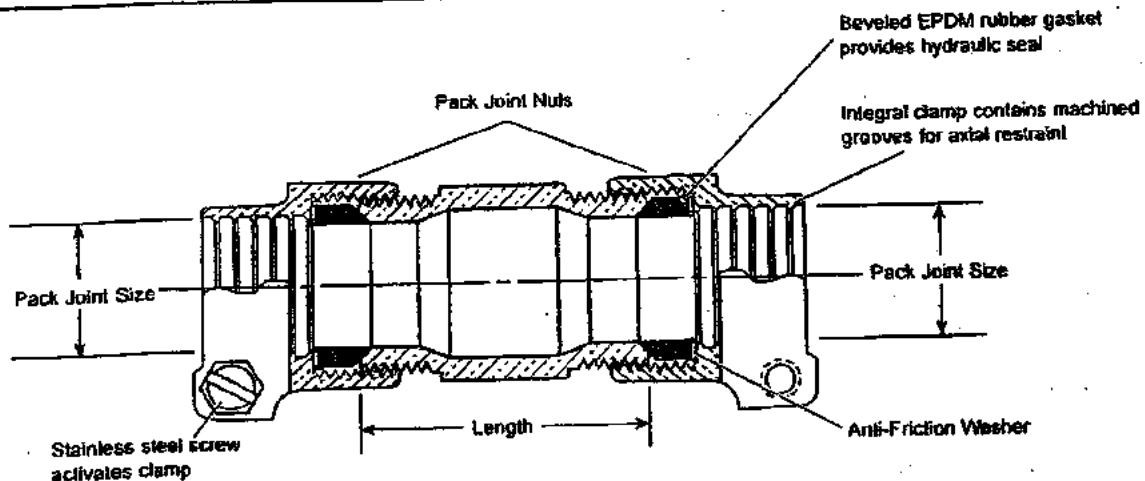

DESCRIPTION		LENGTH	APPROX. Wt. Lbs	PART NUMBER	✓ SUBMITTED Item(s)
P.J. FOR CTS	P.J. FOR CTS				
1/2"	1/2"	1-7/8"	.7	C44-11-NL	
1/2"	5/8"	2-1/16"	.7	C44-12-NL	
1/2"	3/4"	2"	.8	C44-13-NL	
1/2"	1"	2-5/16"	.9	C44-14-NL	
5/8"	5/8"	2"	1.0	C44-22-NL	
5/8"	3/4"	2-1/16"	1.0	C44-23-NL	
3/4"	3/4"	2"	.9	C44-33-NL	
3/4"	1"	2-1/8"	1.0	C44-34-NL	
1"	1"	2-1/8"	1.1	C44-44-NL	
1"	1-1/4"	1-15/16"	1.5	C44-45-NL	
1"	1-1/2"	2-5/8"	2.1	C44-46-NL	
1-1/4"	1-1/4"	2-1/2"	1.5	C44-55-NL	
1-1/4"	1-1/2"	3-1/4"	2.8	C44-56-NL	
1-1/2"	1-1/2"	3-5/8"	3.0	C44-66-NL	
1-1/2"	2"	2-1/2"	3.5	C44-67-NL	
2"	2"	3-15/16"	4.5	C44-77-NL	

Note: Ford recommends using insert stiffeners with plastic pipe or tubing.



FEATURES

- All brass that comes in contact with potable water conforms to AWWA Standard C800 (UNS NO C89833)
- Brass components that do not come in contact with potable water conform to AWWA Standard C800 (ASTM B-62 and ASTM B-584, UNS NO C83600 - 85-5-5-5)
- Sleeve design provides hexagonal wrench flats for proper installation.
- The product has the letters "NL" cast into the main body for proper identification
- UL Classified to ANSI/NSF Standard 61 and Annex G

The Ford Meter Box Company considers the information in this submittal form to be correct at the time of publication. Item and option availability, including specifications, are subject to change without notice. Please verify that your product information is current.



The Ford Meter Box Company, Inc.
 P.O. Box 443, Wabash, Indiana U.S.A. 46992-0443
 Phone: 260-563-3171 / Fax: 800-826-3487
 Overseas Fax: 260-563-0167
<http://www.fordmeterbox.com>

12/06/11

Submitted By:

BOARD OF WATER SUPPLY

CITY AND COUNTY OF HONOLULU
630 SOUTH BERETANIA STREET
HONOLULU, HI 96843



April 29, 2016

KIRK CALDWELL, MAYOR



DUANE R. MIYASHIRO, Chair
ADAM C. WONG, Vice Chair
DAVID C. HULIHEE
KAPUA SPROAT
BRYAN P. ANDAYA

ROSS S. SASAMURA, Ex-Officio
FORD N. FUCHIGAMI, Ex-Officio

ERNEST Y. W. LAU, P.E.
Manager and Chief Engineer

ELLEN E. KITAMURA, P.E.
Deputy Manager and Chief Engineer 

TO: WHOM IT MAY CONCERN

FROM:  ERNEST Y. W. LAU, P.E., MANAGER AND CHIEF ENGINEER 
BOARD OF WATER SUPPLY

SUBJECT: 2002 WATER SYSTEM STANDARDS AMENDMENT

For Oahu only, the 2002 Water System Standards shall be amended as follows:

DIVISION 400 – APPROVED MATERIALS LIST AND STANDARD DETAILS, Section
403 – Standard Details:

1. Delete Standard Detail P10 TRENCH BACKFILL and replace with the enclosed Standard Detail P10 TRENCH BACKFILL (2016 Revision) which reflects the increase in cushion material below the pipe to 12 inches.

All construction plans received by the Board of Water Supply after May 20, 2016, shall comply with the above amendment.

If you have any questions, please contact Michael Domion, Support Branch Head, Capital Projects Division, at 748-5740.

Enclosure

cc: Hawaii, Kauai and Maui Water Departments

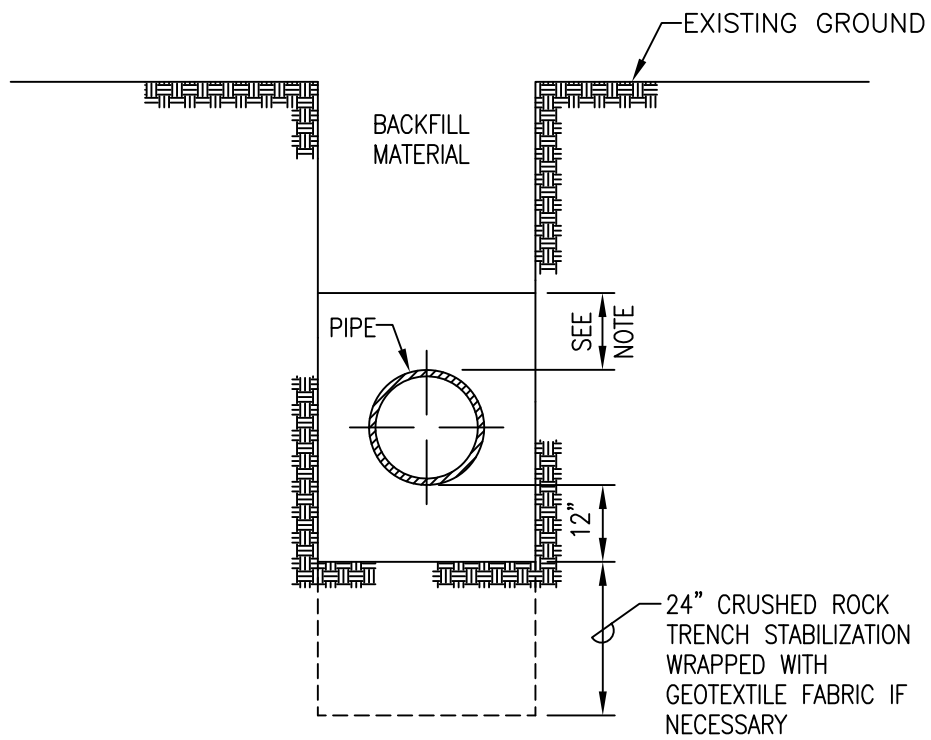

NOTE:

1. 12" OF CUSHION MATERIAL FOR PIPES 16" OR LARGER. 6" CUSHION MATERIAL FOR PIPES 12" OR SMALLER AT LOCATIONS WHERE INVERT IS ABOVE 4-FOOT ELEVATION.
2. 12" OF CUSHION MATERIAL FOR ALL PIPE SIZES AT LOCATIONS WHERE THE INVERT IS AT OR BELOW THE 4-FOOT ELEVATION.

2016
REVISION

OAHU	TRENCH BACKFILL SCALE: NTS	STANDARD DETAILS	P10
------	--------------------------------------	---------------------	------------

BOARD OF WATER SUPPLY

CITY AND COUNTY OF HONOLULU
630 SOUTH BERETANIA STREET
HONOLULU, HI 96843



April 15, 2016

KIRK CALDWELL, MAYOR

DUANE R. MIYASHIRO, Chair
ADAM C. WONG, Vice Chair
DAVID C. HULIHEE
KAPUA SPROAT
BRYAN P. ANDAYA

ROSS S. SASAMURA, Ex-Officio
FORD N. FUCHIGAMI, Ex-Officio

ERNEST Y. W. LAU, P.E.
Manager and Chief Engineer

ELLEN E. KITAMURA, P.E.
Deputy Manager and Chief Engineer

Supp.

TO: WHOM IT MAY CONCERN
FROM: ERNEST Y.W. LAU, P. E., MANAGER AND CHIEF ENGINEER
BOARD OF WATER SUPPLY
SUBJECT: 2002 WATER SYSTEM STANDARDS AMENDMENT

Ernest

For Oahu only, the 2002 Water System Standards shall be amended as follows:

DIVISION 200 – MATERIALS, Section 202 – Ductile Iron Pipe, Fittings, and Appurtenances:

- 1. Delete Table 200-1 – STANDARD DIMENSIONS OF MECHANICAL JOINT And PUSH-ON JOINT DUCTILE IRON PIPE and replace with the following table:

Table 200-1 – STANDARD DIMENSIONS OF MECHANICAL JOINT AND PUSH-ON JOINT DUCTILE IRON PIPE (Revised 4/2016 - FOR OAHU ONLY)			
Pipe Size (Inches)	Thickness (Class)	Thickness (Inches)	Outside Diameter (Inches)
4	53	0.32	4.80
6	53	0.34	6.90
8	53	0.36	9.05
12	53	0.40	13.20
16	53	0.43	17.40
20	53	0.45	21.60
24	53	0.47	25.80
30	53	0.51	32.00
36	53	0.58	38.30
42	53	0.65	44.50

2002 Water System Standards Amendment
April 15, 2016
Page 2

The thicker class of ductile iron pipe will provide better protection from the corrosive soils on Oahu.

All construction plans received by the Board of Water Supply after April 29, 2016, shall comply with the above amendment.

If you have any questions, please contact Michael Domion, Support Branch Head, Capital Projects Division, at 748-5740.

BOARD OF WATER SUPPLY

CITY AND COUNTY OF HONOLULU
630 SOUTH BERETANIA STREET
HONOLULU, HI 96843



May 13, 2015

KIRK CALDWELL, MAYOR

DUANE R. MIYASHIRO, Chair
ADAM C. WONG, Vice Chair
THERESIA C. McMURDO
DAVID C. HULIHEE
KAPUA SPROAT

ROSS S. SASAMURA, Ex-Officio
FORD N. FUCHIGAMI, Ex-Officio

ERNEST Y. W. LAU, P.E.
Manager and Chief Engineer

ELLEN E. KITAMURA, P.E.
Deputy Manager and Chief Engineer

Mr. Jeff Smith, Regional Sales Manager
DFW Plastics, Inc.
P.O. Box 648
Bedford, Texas 76095

Dear Mr. Smith:

Subject: Your Letter Dated March 7, 2014, Regarding Request of Product Approval

We approve the DFW Type X Meter Box and Cover (DFW1425C-12-1CA BWS) for inclusion into the Approved Materials List of the Water System Standards for Oahu only.

If you have any questions, please contact Michael Domion, Support Branch Head, of the Capital Projects Division, at (808)748-5740.

Very truly yours,

ERNEST Y. W. LAU, P.E.
Manager and Chief Engineer

REVISIONS		
REV	DESCRIPTION	DATE
NR	NEW RELEASE	03/07/14

LID KEY	
1	BLACK COLOR
C	CAST IRON READER DOOR 4x7
A	AMR SLIDE MOUNT
BWS	BWS ENGRAVING

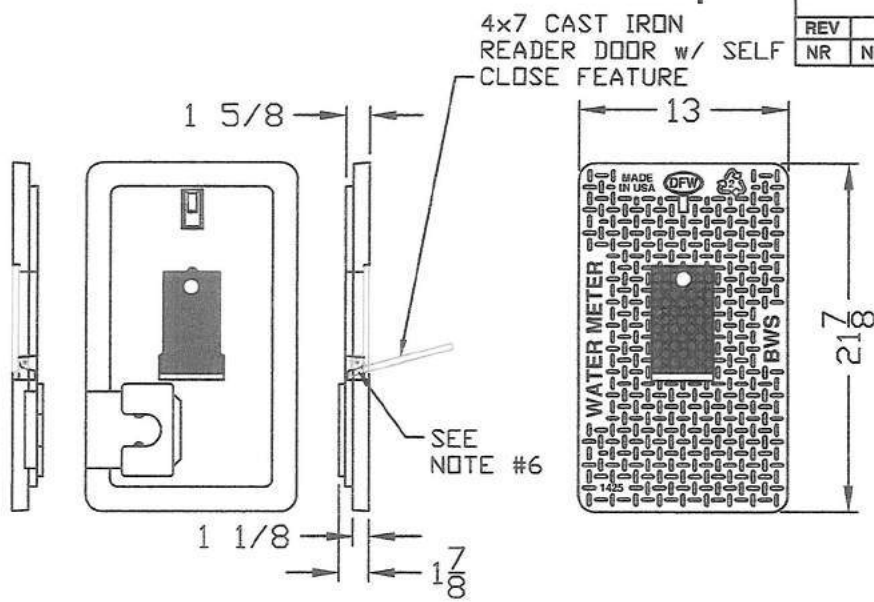

DFW1425C-1CA BWS-LID

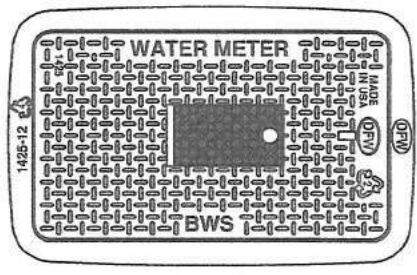
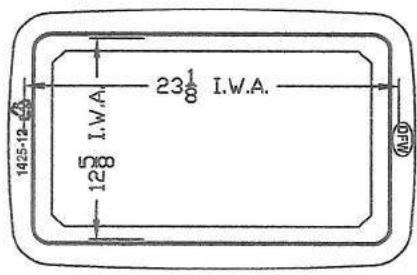
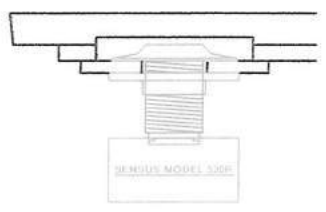

DFW1425C-12-1CA BWS

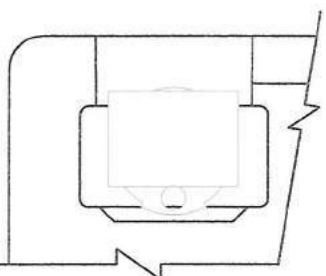

**SENSUS ERT INSTALLED
MODEL 520R**

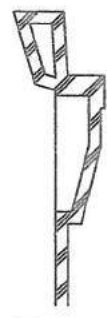
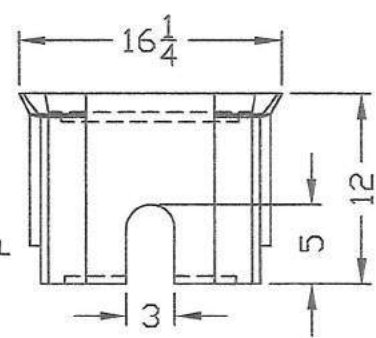
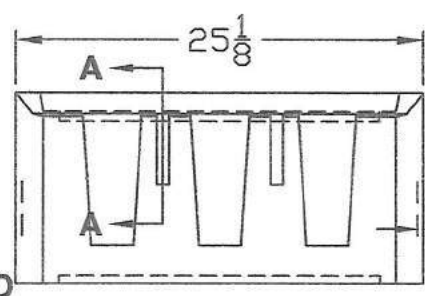

SECTION A-A

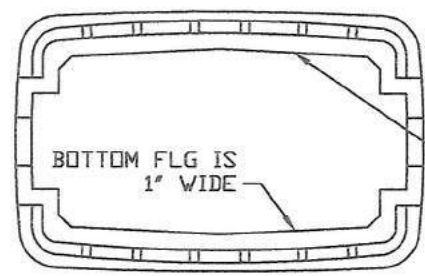

SIDES ARE BOWED OUT 1/2" TO HELP WITH BACK FILL

DFW1425C-12-BODY

DFW PLASTICS, INC. ENGAGES IN ONGOING RESEARCH AND DEVELOPMENT TO IMPROVE AND ENHANCE ITS PRODUCTS. THEREFORE, DFW PLASTICS, INC. RESERVES THE RIGHT TO CHANGE PRODUCT OR SYSTEM SPECIFICATIONS WITHOUT NOTICE.

NOTES

- 1) DIM'S ± 1/8 U.N.O.
- 2) LID MATERIAL: H.D.P.E.
- 3) BODY MATERIAL: L.L.P.E.
- 4) WALL THICKNESS: 3/8 ± 5%
- 5) I.W.A. = INSIDE WORK AREA
- 6) ø3/16" x 6" LONG ECO TECH STEEL PIN IMPREGNATED WITH ZINC & ALUMINUM FOR CORROSION RESISTANCE. CHROMIUM FREE.



DFW PLASTICS, INC.
PO BOX 648
BEDFORD, TEXAS 76095
(817) 439-3600
(817) 439-3700 (f)
www.dfwplasticsinc.com

DFW1425C-12-1CA BWS

CREATED:	03/07/14
UPDATED:	*
ACCEPTED:	*
DRAWN BY:	J.C.A.
PLOT SCALE:	1:12

BOARD OF WATER SUPPLY

CITY AND COUNTY OF HONOLULU
630 SOUTH BERETANIA STREET
HONOLULU, HI 96843



April 23, 2015

KIRK CALDWELL, MAYOR

DUANE R. MIYASHIRO, Chair
ADAM C. WONG, Vice Chair
THERESIA C. McMURDO
DAVID C. HULIHEE
KAPUA SPROAT

ROSS S. SASAMURA, Ex-Officio
FORD N. FUCHIGAMI, Ex-Officio

ERNEST Y. W. LAU, P.E.
Manager and Chief Engineer

ELLEN E. KITAMURA, P.E.
Deputy Manager and Chief Engineer

TO: WHOM IT MAY CONCERN

FROM: ERNEST Y. W. LAU, P.E., MANAGER AND CHIEF ENGINEER *ELW*
BOARD OF WATER SUPPLY

SUBJECT: 2002 WATER SYSTEM STANDARDS AMENDMENT

For Oahu only, the 2002 Water System Standards shall be amended as follows:

Division 200 - MATERIALS:

1. Delete Section 204 – PLASTIC PIPE in its entirety and replace with the enclosed Section 204 – PLASTIC PIPE, Revised 4/2015

Division 300, Section 302 – WATER MAINS AND APPURTENANCES:

2. Delete section 302.14 PLASTIC PIPE in its entirety and replace with the enclosed section 302.14 PLASTIC PIPE, Revised 4/2015.
3. Delete section 302.15 FITTINGS AND SPECIALS (DUCTILE IRON, AND CONCRETE CYLINDER) in its entirety and replace with the enclosed section 302.15 – FITTINGS AND SPECIALS (DUCTILE IRON, AND CONCRETE CYLINDER), Revised 4/2015

The elimination of DR18 plastic pipe and PVC fittings, and requiring DR14 for all plastic pipe installations will provide better protection from unknown transient pressure in our water system and will better withstand potential damage during transport, handling and installation.

All construction plans received by the Board of Water Supply **after April 30, 2015** shall comply with the above amendments.

If you have any questions, please contact Michael Domion of the Capital Projects Division at (808) 748-5740.

Enclosures

SECTION 204 - PLASTIC PIPE

204.01 POLYVINYL CHLORIDE (PVC) C-900 & C-905 PIPE.

A. General. PVC C-900 and C-905 pipe shall be cast-iron-pipe-equivalent O.D. type as called for in the Bid, Plans, and Specifications. All PVC C-900 and C-905 pipe and materials used for potable service shall be NSF 61 certified.

Only elastomeric-gasket type joints shall be allowed. Pipe shall be furnished complete with integral bells, with gaskets conforming to ASTM F477 and NSF 61, and lubricants conforming to NSF 61. All gaskets and lubricants shall be made from materials that are compatible with the plastic material and with each other when used together. The material shall not support the growth of bacteria nor adversely affect the potable quality of the water that is to be transported.

Electronic markers shall be installed over the PVC pipe for its entire length in accordance to the plans and specification. See Division 500 for corrosion protection requirements as applicable to the project.

PVC pipe deflection at the bell is not allowed. Deflections at ductile iron fittings shall be in accordance to Section 102.07 DEFLECTION PER JOINT. Bending of PVC pipes is not allowed.

B. AWWA C900 PVC PIPE. PVC C900 pipe shall be in compliance with Table 200-5 and AWWA C900, " Polyvinyl Chloride (PVC) Pressure Pipe and Fabricated Fittings, 4-Inch Through 12-Inch for Water Transmission and Distribution".

Table 200-5 - PVC C900 PIPE STANDARD DIMENSIONS				
Pipe Size (In.)	Class (psi)	DR	Thickness (In.)	Outside Diameter (In.)
4	150	14	0.343	4.800
6	150	14	0.493	6.900
8	150	14	0.646	9.050
12	150	14	0.943	13.200

DIVISION 200 - MATERIALS

C. AWWA C905 PVC Pipe. PVC C905 pipe shall be in compliance with Table 200-6 and AWWA C905, "Polyvinyl Chloride (PVC) Pressure Pipe and Fabricated Fittings, 14-Inch Through 48-Inch, for Water Transmission and Distribution".

Table 200-6 - PVC C905 PIPE STANDARD DIMENSIONS				
Pipe Size (In.)	Class (psi)	DR	Thickness (In.)	Outside Diameter (In.)
16	150	14	1.243	17.400

D. Fittings.

1. Ductile Iron Fittings. Ductile iron fittings used with PVC C900 and C905 pipes shall conform to SECTION 202 – DUCTILE IRON PIPE, FITTINGS, AND APPURTENANCES.

2. PVC Fittings. PVC fittings, including deflection couplings are not approved.

302.14 PLASTIC PIPE.

A. General. Plastic pipe shall be installed at the location and to the lines, grades and details shown on the plans. No bending of plastic pipe shall be allowed unless specified otherwise.

Electronic markers shall be installed over the entire length of plastic pipe for "toning" purpose in accordance to the plans and specification.

When tapping for service connections and air relief valves, service saddles or tapped tees shall be used. The installation of service saddles or tapped tees shall be as specified for service laterals and connections. *(For Oahu only: Service saddles allowed only for tapping to existing mains and taps for ball corps at main valves and air relief valves where valves are to be installed in manholes.)*

Plastic pipe deflection at the bell is not allowed. Deflections at ductile iron fittings shall be in accordance to Section 102.07 DEFLECTION PER JOINT. For plastic pipes, the installation according to the plans and specifications may require additional fittings, and items of work not specified in the plans and specifications due to no deflection being allowed at the bell. Bending of plastic pipes is not be allowed. Deflections at ductile iron fittings shall be in accordance to Section 102.07 DEFLECTION PER JOINT.

Any additional design modification and/or work required due to no deflection being allowed at the joints shall be the responsibility of the Contractor and shall be approved by the Department.

B. Payment. Payment for the furnishing and installation of the various sizes of PVC PIPE, including all necessary joint accessories, will be made at the respective Unit Price Bids per linear foot based on the actual linear feet of PVC PIPE installed (exclusive of valves, fittings, bends and adapters), cleaned or pigged and successfully hydrotested.

The Unit Price Bids for the furnishing and installation of PVC PIPE shall be full compensation for all labor, materials, tools and equipment for all handling, hauling, unloading, placing, cutting, jointing, testing, dewatering, painting, installing, and service saddles and all other incidentals required to complete the work.

Measurement and payment for ductile iron fittings shall be as specified in Section 302.15 - FITTINGS AND SPECIALS (DUCTILE IRON, CONCRETE CYLINDER, PLASTIC PVC PIPE) of the Water System Standards.

For Oahu only for service connections and air relief valves: Payment for service saddles, if allowed by the Department, will be made at the respective Unit Price Bid based on the actual number of SERVICE SADDLES installed and tested. Payment for tapped tees or bossed tees (with tap sizes specified) will be made at the Unit Bid Price per pound of DUCTILE IRON FITTINGS based on the total weight of the tapped tees installed and tested.

302.15 FITTINGS AND SPECIALS (DUCTILE IRON AND CONCRETE CYLINDER).

A. General. The Contractor shall furnish and install the various types of fittings and specials (ductile iron or concrete cylinder) at locations shown on the plans or as directed by the Manager. Installation shall be in the same manner prescribed elsewhere in these Standards for the various types of pipe joints. *(For Oahu only: Buried ductile iron fittings shall be encased with 2 layers of 8 mil polyethylene wrap.)*

For concrete cylinder pipes, fittings may be fabricated to be integral with a straight section of pipe with the understanding that any field adjustments required will be done at no cost to the Department.

B. Payment. Payment for the furnishing and installation of DUCTILE IRON FITTINGS will be made at the Unit Price Bid per pound or per each fitting, based on the total body weight of the fittings or the actual number of DUCTILE IRON FITTINGS installed and tested.

The total weight of the various sizes and types of DUCTILE IRON FITTINGS shall be the sum of the body weights of the fittings based on the weights given in the latest edition of the "Handbook of Ductile Iron Pipe" by the Ductile Iron Pipe Research Association. If the weight of any fitting is not given in the handbook, the weight shall be based on the actual weight marked on that fitting. Weights of jointing accessories are considered incidental.

Payment for furnishing and installing CONCRETE CYLINDER FITTINGS AND SPECIALS will be made at the respective Unit Price Bids based on the actual number installed and tested.

Payment for FLANGED BY BELL ADAPTERS and FLANGED DISMANTLING JOINTS will be made at the respective Unit Price Bids based on the actual number installed and tested. Flanges shall be per ANSI B16.1, Class 125 or 250.

The Unit Price Bids for furnishing and installing fittings and specials (DUCTILE IRON or CONCRETE CYLINDER) shall be full compensation for all labor, materials, tools and equipment for all handling, hauling, unloading, placing, poly-wrapping, jointing, testing, bracing and blocking and other incidentals necessary to complete the work.

BOARD OF WATER SUPPLY

CITY AND COUNTY OF HONOLULU
630 SOUTH BERETANIA STREET
HONOLULU, HI 96843



April 23, 2015

KIRK CALDWELL, MAYOR

DUANE R. MIYASHIRO, Chair
ADAM C. WONG, Vice Chair
THERESIA C. McMURDO
DAVID C. HULIHEE
KAPUA SPROAT

ROSS S. SASAMURA, Ex-Officio
FORD N. FUCHIGAMI, Ex-Officio

ERNEST Y. W. LAU, P.E.
Manager and Chief Engineer

ELLEN E. KITAMURA, P.E.
Deputy Manager and Chief Engineer

TO: WHOM IT MAY CONCERN

FROM: ERNEST Y. W. LAU, P.E., MANAGER AND CHIEF ENGINEER *EYL*
BOARD OF WATER SUPPLY

SUBJECT: 2002 WATER SYSTEM STANDARDS AMENDMENT

Division 100, Section 102 – MAINS, Subsection 102.01 LOCATION:

For Oahu only, delete Table 100-1 - WATER MAIN CLEARANCES and replace with the following:

Table 100-1 – WATER MAIN CLEARANCES			
Island	Utility Diameter (Inches)	Clearances	
		Horizontal (Feet)	Vertical (Inches)
Hawaii	All Sizes	8	18 ^a
Kauai	All Sizes	8	18 ^b
Maui	<16	3	6 ^b
Maui	≥16	3	12 ^b
Oahu	All Sizes	3 ^c	12 ^b

- a - Provided other utility mains are concrete jacketed.
- b - For trenchless installation work (micro-tunneling, directional drilling, pipe ramming/jacking of new utilities such as electrical duct lines, sewer lines, drain lines) crossing or paralleling existing water mains, provide three-foot vertical clearances to existing mains.
- c - Five-foot clearance to water mains 16-inches and larger.

The additional clearances will help facilitate the maintenance of our pipeline infrastructure. All construction plans received by the Board of Water Supply after April 30, 2015 shall comply with the above amended Table 100-1 – WATER MAIN CLEARANCES.

If you have any questions, please contact Michael Domion of the Capital Projects Division at (808)748-5740.

BOARD OF WATER SUPPLY

CITY AND COUNTY OF HONOLULU
630 SOUTH BERETANIA STREET
HONOLULU, HI 96843



December 8, 2014

KIRK CALDWELL, MAYOR

DUANE R. MIYASHIRO, Chair
ADAM C. WONG, Vice Chair
MAHEALANI CYPHER
THERESIA C. McMURDO
DAVID C. HULIHEE

ROSS S. SASAMURA, Ex-Officio
FORD N. FUCHIGAMI, Ex-Officio

ERNEST Y. W. LAU, P.E.
Manager and Chief Engineer

ELLEN E. KITAMURA, P.E.
Deputy Manager and Chief Engineer 

TO: WHOM IT MAY CONCERN

FROM: ERNEST Y. W. LAU, P.E., MANAGER AND CHIEF ENGINEER
BOARD OF WATER SUPPLY 

SUBJECT: 2002 WATER SYSTEM STANDARDS AMENDMENTS

The following amendment to the 2002 Water System Standards is effective immediately for Oahu only:

Division 400, Section 403 STANDARDS DETAILS:

Replace the following details with the enclosed details (2014 Revision) which reflect the new splice length of 7-1/2" for a 3/4" meter:

<u>Standard Detail</u>	<u>Description</u>
L14	Copper Service lateral for Connection Type "X" Meter Box 5/8", 3/4", & 1" Meters
L18	Material List for Copper Laterals

If you have any questions, please contact Michael Domion, Support Branch Head, Capital Projects Division, at 748-5740.

Enclosure

cc: Kauai, Maui, Hawaii Water Departments

NOTES:

1. SEE M3 FOR DETAILS OF TYPE "X" METER BOX.
2. IF THE CONSUMER'S SERVICE VALVE CANNOT BE INSTALLED 3-5 FEET FROM THE PROPERTY LINE, THE VALVE SHALL BE INSTALLED AS DIRECTED BY THE MANAGER, OR INSTALL BALL CORP. WITHIN METER BOX AFTER METER.
3. SEE PLATE M43 FOR METER INSTALLATION IN NON-SIDEWALK AREA.

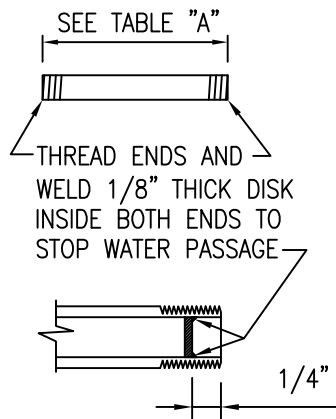

TABLE "A"		
METER SIZE	SPLICE SIZE	SPLICE LENGTH
5/8"	1" DIA.	7 1/2"
3/4"	1" DIA.	7 1/2"
1"	1 1/4" DIA.	10 3/4"

METER SPLICE DETAIL

2014
REVISION

OAHU	COPPER SERVICE LATERAL FOR CONNECTION TYPE "X" METER BOX 5/8", 3/4", & 1" METERS SCALE: NTS	STANDARD DETAILS	L14
------	--	---------------------	-----

OAHU

MATERIAL LIST
FOR COPPER LATERALS
 SCALE: NTS

STANDARD
 DETAILS

L18

TABLE A (COPPER)

METER CODE	METER SIZE	LOW RANGE FOR METER SIZING (GPM)	LATERAL TYPE	LATERAL SIZE	SPLICE SIZE	SPLICE LENGTH	METER COUPL'G	BRASS REDUC.	SERVICE VALVE	BRASS PIPE	CAP	METER BOX
02	5/8"	20	"A"	1"	1" DIA.	7 1/2"	3/4"	1"x3/4"	1"	1"x10"	1"	TYPE X
03	3/4"	30	"A"	1"	1" DIA.	7 1/2"	3/4"	1"x3/4"	1"	1"x10"	1"	TYPE X
04	1"	50	"C"	1-1/2"	1" DIA.*	10 3/4"	1"	1 1/2"x1"	1 1/2"	1 1/2"x10"	1 1/2"	TYPE X
06	1 1/2"	100	"D"	2"	1 1/2" DIA.	13" R.E.	1 1/2 FL.	NONE	1 1/2"	1 1/2"x10"	1 1/2"	TYPE III
07	2"	160	"E"	2-1/2"	2" DIA.**	17" R.E.	2" FL.	NONE	2"	2"x10"	2"	TYPE III

* INCLUDES 2-1 1/4" x 1" BUSHINGS
 ** INCLUDES 2-2" x 2 1/2" BUSHINGS

MAXIMUM METER SIZES FOR DOMESTIC SERVICE LATERALS	
LATERAL TYPE	MAXIMUM METER SIZE FOR COMMON SERVICE LATERAL
"A"	3/4"
"C"	1"
"D"	1-1/2"
"E"	2"
	1-1/2" & 1"

2014
 REVISION

BOARD OF WATER SUPPLY

CITY AND COUNTY OF HONOLULU
630 SOUTH BERETANIA STREET
HONOLULU, HI 96843



September 19, 2014

KIRK CALDWELL, MAYOR

DUANE R. MIYASHIRO, Chair
ADAM C. WONG, Vice Chair
MAHEALANI CYPHER
THERESIA C. McMURDO
DAVID C. HULIHEE

ROSS S. SASAMURA, Ex-Officio
FORD N. FUCHIGAMI, Ex-Officio

ERNEST Y. W. LAU, P.E.
Manager and Chief Engineer

ELLEN E. KITAMURA, P.E.
Deputy Manager and Chief Engineer *lit*

Ms. Maureen Patton
Water Works Specialties Manager
T. Christy Enterprises, Inc.
655 East Ball Road
Anaheim, California 92805

Dear Ms. Patton:

Subject: Your Letter Dated March 26, 2014, Regarding Request for
Approval of Christy's Polyethylene Encasement (Polywrap)

We approve the Christy's Polywrap for inclusion into the Approved Material List of the Water System Standards for Oahu only.

If you have any questions, please contact Michael Domion, Support Branch Head of the Capital Projects Division, at (808)748-5740.

Very truly yours,

ERNEST Y. W. LAU, P.E.
Manager and Chief Engineer

cc: Kauai Department of Water
Maui Department of Water Supply
Hawaii Department of Water Supply
D. Hiromoto, D. Ching, L. Fujikami, M. Domion

MD:es

14-0525



140525

CP
sample given to CP 5/6/14

2014 MAY -6 P 2:32
RECEIVED
WATER SUPPLY

3/26/2014

Mr. Ernest Y.W. Lau
Manager and Chief Engineer
Board of Water Supply
630 South Beretania Street
Honolulu, Hawaii 96843

RE: Request for Approval of Christy's Polyethylene Encasement (Polywrap)

I am writing to respectfully request your consideration in approving Christy's Polywrap for inclusion on your Approved Material List. Our linear low density polyethylene encasement is made in conformance with the material requirements of ANSI/AWWA C105/A21.5-10 and ASM D4976 and NT4112-10.

I have included our Product Data Sheet and a Sample of our Blue Polywrap for your review. We manufacture this material in Clear, Black, Blue, Green and Purple. The sizes vary depending on the color.

We also offer this same product in a 3' wide sheet that comes on a 100' roll and is clear. This product was developed for ease of use in wrapping valves and fitting and irregular items. It is known as our Fitting Wrap.

Christy's Polywrap is Made in the USA and has been used for over 25 years all over the United States. Our main distribution facility is located in Anaheim, CA.

Thank you very much for your consideration in this matter. Should you have any questions or need anything additional, please don't hesitate to contact me. We look forward to the opportunity of supplying your material requirements.

Kindest Regards,

Maureen Patton
Water Works Specialties Manager
T. Christy Enterprises, Inc.
655 East Ball Road
Anaheim, CA 92805
Maureen@tchristy.com
714-206-0534

Christy'sTM

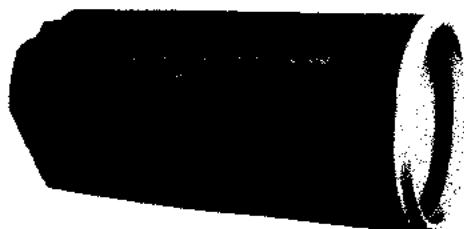

POLYWRAP (Polyethylene Encasement Tubing) **Corrosion Protection for Cast Iron, Ductile Iron and Steel Pipe** AWWA C105-10, ANSI A21.5-10

For over 40 years polyethylene encasement has proven to be an effective method of protecting ductile iron pipe from corrosion. Tests have shown that when loose polyethylene encasement is installed on pipe, it provides an economical means of corrosion protection

- Polyethylene film prevents contact between pipe and the surrounding soil for an economical and effective solution of corrosion protection
- For use on metal piping systems for identification and corrosion protection or PVC pipe for identification purposes such as Reclaimed/Recycled water
- Perforated every 20' or 22' for both 18' and 20' pipe joints
- Diameters available to cover 1/2" through 42" pipe
- Warning message repeats every 18 - 24 inches depending on size
- Printed with current AWWA C105 and ANSI A21.5 specification

PROPERTIES

Material Group	2 (Linear)
Density Class	0.910 to 0.935 g/cm ³ B (Colors)(1)
Dielectric Strength	Volume resistivity 10 ¹⁵ ohm-cm.,min.

Physical Properties

Minimum Tensile Strength	3600 PSI (24.8 MPa- ASTM D882)
Minimum Elongation	800% (ASTM 882)
Minimum Dielectric Strength	800 V/mil (ASTM D149) Minimum
Impact Resistance	600 g (ASTM D1709 Method B)
Propagation Tear Resistance	2550 gf (ASTM D1922)
Thickness	Minimum of 0.008 in. (8 mils)
Colors Available	Black, Clear, Purple, Blue, Green.

INSTALLATION

Install polywrap according to the latest AWWA or DIPRA guidelines. Use with Christy's Polyethylene (Visqueen) Fitting Wrap and Pipewrap Tape

PRODUCT SPECIFICATIONS

Manufactured of virgin polyethylene material

8 mil minimum, group 2, linear low density

Conforms to the material requirements of the latest revision of ANSVAWWA C105/A21.5-10 and ASTM D4976 and NT4112-10

Film is imprinted every 18"-24" with:

- Trademark
- Year of manufacture
- Type of resin
- Specification conformance
- Applicable pipe sizes
- Text "Warning Corrosion Protection - Repair any Damage". Purple Polywrap verbiage reads "Recycled/Reclaimed Water Line"

Sizing Guidelines: Pipe Diameter/Polywrap Size

Through 6"	16" polywrap
Through 8"	20" polywrap
Through 10"	24" polywrap
Through 12"	27" polywrap
Through 14"	30" polywrap
Through 16"	34" polywrap
Through 18"	37" polywrap
Through 20"-24"	54" polywrap
Through 30"	67" polywrap
Through 36"	84" polywrap
Through 42"	84" polywrap

Larger sizes available upon request

T. Christy Enterprises, Inc.
655 E Ball Rd • Anaheim, CA 92805
Tel: (714) 507-3300 • Fax: (714) 507-3310

BOARD OF WATER SUPPLY

CITY AND COUNTY OF HONOLULU
630 SOUTH BERETANIA STREET
HONOLULU, HI 96843



June 20, 2014

KIRK CALDWELL, MAYOR

DUANE R. MIYASHIRO, Chair
MAHEALANI CYPHER, Vice Chair
THERESIA C. McMURDO
ADAM C. WONG
DAVID C. HULIHEE

ROSS S. SASAMURA, Ex-Officio
FORD N. FUCHIGAMI, Ex-Officio

ERNEST Y. W. LAU, P.E.
Manager and Chief Engineer

ELLEN E. KITAMURA, P.E.
Deputy Manager and Chief Engineer *pk*

Mr. Jesse Anderson
Clow Valve Company
3126 Verde Avenue
Carlsbad, California 92009

Dear Mr. Anderson:

Subject: Your Letter Dated March 20, 2014, Requesting Approval of Clow 850
Fire Hydrant

We approve the updated version of the Clow 850 Fire Hydrant for inclusion into the Water System Standards for Oahu only.

If you have any questions, please contact Michael Domion of the Capital Projects Division at (808)748-5740.

Very truly yours,

ERNEST Y. W. LAU, P.E.
Manager and Chief Engineer *WKL*

cc: Kauai Department of Water Supply
Maui Department of Water Supply
Hawaii Department of Water Supply
D. Hiromoto, D. Ching, L. Fujikami, *M. Domion*

MD:st



CLOW VALVE COMPANY

Website: www.ClowValve.com

California- Wet Barrel Hydrants:
1375 Magnolia Avenue
Corona, CA 92879
Phone: 1(888) 889-2411
Fax: (951) 735-0837

Corporate & Engineering:
902 South 2nd Street
Oskaloosa, IA 52577
Phone: 1(800) 829-2569
Fax: (641) 673-8269

March 20th, 2014

Mr. Ernest Y.W. Lau
Manager and Chief Engineer
Board of Water Supply
630 South Beretania Street
Honolulu, Hawaii 96843

Dear Mr. Lau,

Clow Valve Company would like to submit for approval the following items to be added to the approved material list for **Section 206.01 and 206.02 Wet Barrel Fire Hydrants**. Clow Valve would like to update the current wet barrel hydrant specification.

Clow 850 Fire Hydrant
Product Submittal/Paint Specification (Enclosed)

206.01 Paint Coating now made with Ellis MX-5500-Y001 Maximus Polyurethane 100 VOC Safety Yellow. Per California Environmental changes with new (VOC) requirements.

206.02 Clow 850 Fire Hydrant brass internals and outlets made with Eco-Brass (C87850).

206.02 Composition of the valve rubber shall be Urethane. Valve and valve carrier shall be attached to the operating stem utilizing an "O" ring seal to prevent leakage through the valve. Stem packing shall be of the "O" ring type incorporating two "O" rings in the stem sleeves.

Thank you for taking the time to consider our product for approval.
Sincerely,

Jesse Anderson
Clow Valve Company
3126 Verde Ave.
Carlsbad, CA 92009

A Division of McWane, Incorporated.



For Generations

Valve & Hydrant Group



Effective 2014 (January)

Subject: Certificate of Compliance – 800 Series Fire Hydrant

Clow Valve Company manufactures the 800 series wet-barrel fire hydrant in the United States of America with compliance to the following criteria.

Product

- AWWA C503, Wet-Barrel Fire Hydrants (200psi rating)
- AWWA C550, Protective Interior Coatings for Valves and Hydrants
- UL 246, Hydrants for Fire-Protection Service (850/860 with 200psi rating)
- FM Class Number 1511, Fire Hydrants (Wet-Barrel Type) for Private Fire Service (850/860 with 175psi rating)
- NSF/ANSI 61, Drinking Water System Components – Health Effects (with Annex G) for models 850, 860 and 865
- NSF/ANSI 372, Drinking Water System Components – Lead Content (models 850, 860 and 865)

Materials (where applicable)

- Ductile Iron: ASTM A536 (Grade 65-45-12 minimum strength)
- Gray Iron: ASTM A126 (Class B)
- Copper Alloy:
 - ASTM B16 (C36000)
 - ASTM B98 (C65500)
 - ASTM B584 (C83600, C86700, C87610, C87850, C89833)
 - ASTM B763 (C86700, C87610, C99500)

Compliance with other standards, such as those related to end joint connections, is dictated by compliance with standards listed above. If you have additional questions please call (800) 829-2569 for assistance.

Sincerely,

T. Chad Harbour, P.E., LEED A.P.
Engineering & Quality Manager



For Generations



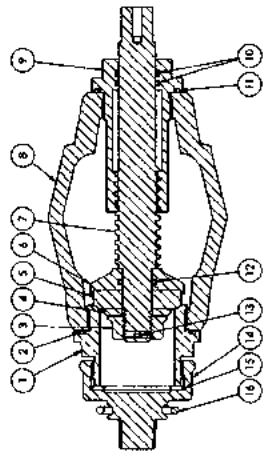
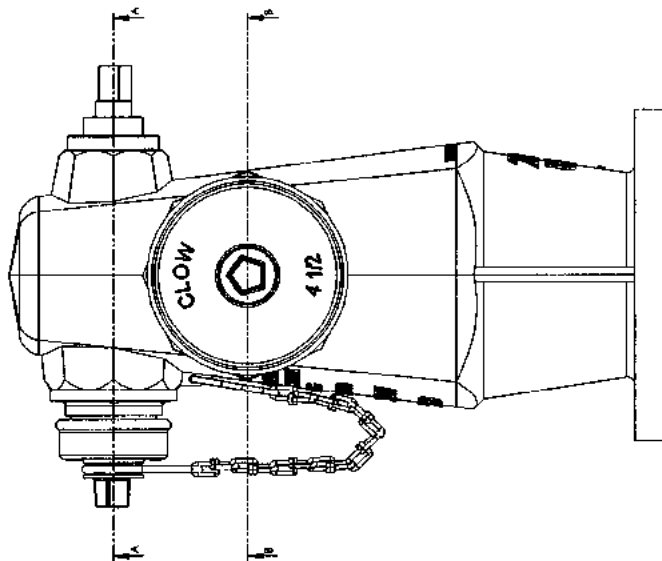
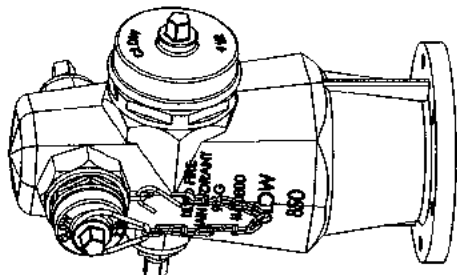

Section A-A
2 1/2" Port Detail

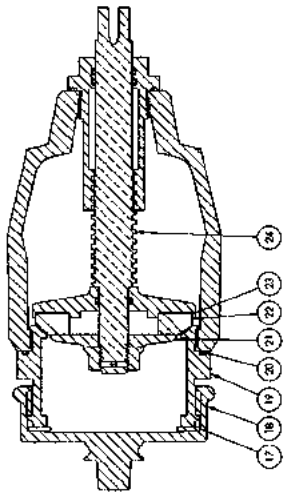

Section B-B
4 1/2" Port Detail

ITEM NO.	DESCRIPTION	MATERIAL	QTY.
1	Outlet - Hose	ASTM B584 C87850	1
2	O-Ring - Hose Outlet	Buna N Rubber	1
3	Slotted Nut	ASTM B584 C87850	2
4	Retainer - Hose	ASTM B584 C87850	1
5	Valve Rubber - Hose	Urethane	1
6	Carrier - Hose	ASTM B584 C87850	1
7	Stem - Hose	ASTM B743 C99500	1
8	Body	A126 Class B Cast Iron	1
9	Stem Sleeve	ASTM B584 C87850	2
10	Stem Sleeve O-Ring - Internal	Buna N Rubber	4
11	Stem Sleeve O-Ring - External	Buna N Rubber	2
12	O-Ring - Carrier	Rubber	2
13	Carrier Pin	Brass	2
14	Cap - Hose	A126 Class B Cast Iron	1
15	Gasket - Hose	Rubber	1
16	Chain Assembly	Zinc Coated Steel	1
17	Gasket - Steamer	Rubber	1
18	Cap - Steamer	A126 Class B Cast Iron	1
19	Nozzle - Steamer	ASTM B584 C87850	1
20	O-Ring - Steamer Outlet	Buna N Rubber	1
21	Retainer - Steamer	ASTM B584 C87850	1
22	Valve Rubber - Steamer	Urethane	1
23	Carrier - Steamer	ASTM B584 C87850	1
24	Stem - Steamer	ASTM B743 C99500	1

Notes:

- Hydrant complies with AWWA C-503 standard for Wet Barrel Fire Hydrants
- Fire hydrant is rated for 200 psi working pressure
- Interior cast surfaces shall be coated with fusion-bonded epoxy powder
- Exterior surfaces to be coated with:
 - Base: Minimum 2 mils DFT of white epoxy paint
 - Finish: Minimum 2 mils DFT polyurethane paint, color to be Safety Yellow

CLOW VALVE COMPANY
 DIV. OF WATKINS INC.
CLOW
 Model 850 Wet Barrel Fire Hydrant
 BWS Submittal Drawing
 Date: 1/18/14
 Rev: 1/18/14
 Scale: 1/2" = 1'-0"
 Project: 100-100000
 Drawing No: 100-100000-001
 Sheet: 1 of 1

BOARD OF WATER SUPPLY

CITY AND COUNTY OF HONOLULU
630 SOUTH BERETANIA STREET
HONOLULU, HI 96843



October 22, 2013

KIRK CALDWELL, MAYOR

DUANE R. MIYASHIRO, Chairman
MAHEALANI CYPHER, Vice Chair
THERESIA C. McMURDO
ADAM C. WONG
DAVID C. HULIHEE

ROSS S. SASAMURA, Ex-Officio
GLENN M. OKIMOTO, Ex-Officio

ERNEST Y. W. LAU, P.E.
Manager and Chief Engineer

ELLEN E. KITAMURA, P.E.
Deputy Manager and Chief Engineer *llk*

TO: WHOM IT MAY CONCERN

FROM: ERNEST Y. W. LAU, P.E. *llk*
MANAGER AND CHIEF ENGINEER

SUBJECT: 2002 WATER SYSTEM STANDARDS AMENDMENTS

All waterworks brass fittings shall be in compliance with the amended Section 1417 of the Safe Drinking Water Act (SDWA) which takes effect on January 4, 2014. The amendment includes a change to the definition of "lead-free" by reducing lead content from 8% to a weighted average of not more than 0.25% in the wetted surface material. All waterworks brass fittings installed for potable water service on January 4, 2014 and beyond shall conform to the amended definition of "lead-free".

As indicated in Section 211 – Brass Products, all brass fitting shall conform to NSF Standard 61 and Section 1417 of the SDWA. In addition, for Oahu only, all brass fittings shall conform to NSF Standard 372. Until conforming brass products are approved for inclusion on the Approved Materials List, brass products must be submitted for review and approval on a project-to-project basis.

If you have any questions, please contact Michael Domion at (808)748-5740.

cc: Kauai, Maui and Hawaii Dept. of Water Supply

BOARD OF WATER SUPPLY

CITY AND COUNTY OF HONOLULU
630 SOUTH BERETANIA STREET
HONOLULU, HI 96843



January 4, 2013

KIRK W. CALDWELL, MAYOR

DUANE R. MIYASHIRO, Chairman
MAHEALANI CYPHER, Vice Chair
THERESIA C. McMURDO
ADAM C. WONG
KAULANA H. R. PARK

ROSS S. SASAMURA, Ex-Officio
GLENN M. OKIMOTO, Ex-Officio

ERNEST Y. W. LAU, P.E.
Manager and Chief Engineer

ELLEN E. KITAMURA, P.E.
Deputy Manager and Chief Engineer *EWL*

Mr. Josh Bivens
Jensen Precast
1255 Nuuanu Avenue, Suite C104
Honolulu, Hawaii 96817

Dear Mr. Bivens:

Subject: Your Letter Dated October 24, 2012, Requesting
Approval of Jensen Precast Meter Boxes

We approve the Jensen Precast Type A valve box and cover, Type B meter box and Type X meter box, for inclusion into the Water System Standards for Oahu only.

Please note that the standard cover for our Type B meter box shall be made of cast iron.

If you have any questions, please contact Michael Domion at 748-5740.

Very truly yours,

Ernest Y. W. Lau
ERNEST Y. W. LAU, P.E.
Manager and Chief Engineer

cc: Kauai Department of Water Supply
Maui Department of Water Supply
Hawaii Department of Water Supply
M. Domion

EA:es

12-1287

2012 OCT 31 P 2: 5889 OF WATER SUPPLY
ADMINISTRATION

2012 OCT 30 A 7 14

JENSEN PRECAST
1255 Nuuanu Ave Suite C104
Honolulu, HI 96817
808-528-1175

121287
mgp
blp
CP
cc: FO

Mr. Ernest Y.W. Lau
Manager and Chief Engineer
Board of Water Supply
630 South Beretania St
Honolulu, HI 96843

October 24, 2012

RE: Request for Product Approval

Dear Mr. Lau,

I am writing you to request the Board of Water Supply's approval of Jensen Precast Meter Boxes. We have recently taken over precast concrete operations for Ameron. The products we are producing will be the same that Ameron was approved to make for the Board of Water Supply. Jensen Precast is an NPCA Certified material supplier, with our production plant in the Campbell Industrial Park in Kapolei, HI. We would like approval to build the following Board of Water Supply Products:

1. Board of Water Standard Detail V13 -- Type A Meter Box
2. Board of Water Standard Detail M1 -- Type B Meter Box
3. Board of Water Standard Detail M3 -- Type X Meter Box

Please see the enclosed shop drawings for your consideration. If I can answer any questions or be of any assistance please don't hesitate to contact me. We appreciate your consideration to become an approved supplier and look forward to hearing from you.

Sincerely,

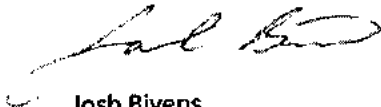

Josh Bivens
Product Applications Specialist
808-321-4665
jbivens@jensenprecast.com

TYPE "A" VALVE BOX & CONCRETE COVER

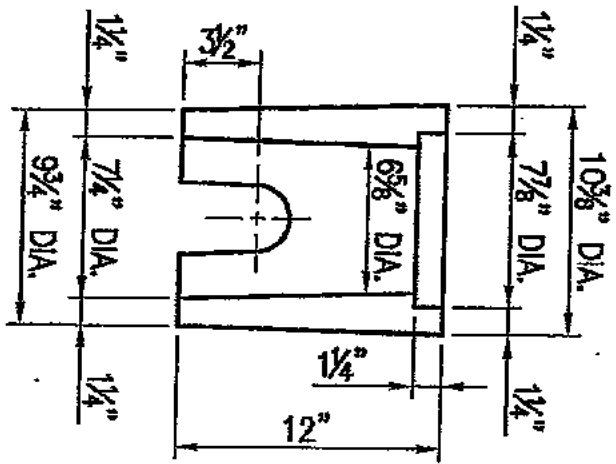

SECTION OF BOX

WEIGHT: = 16.0 lbs.

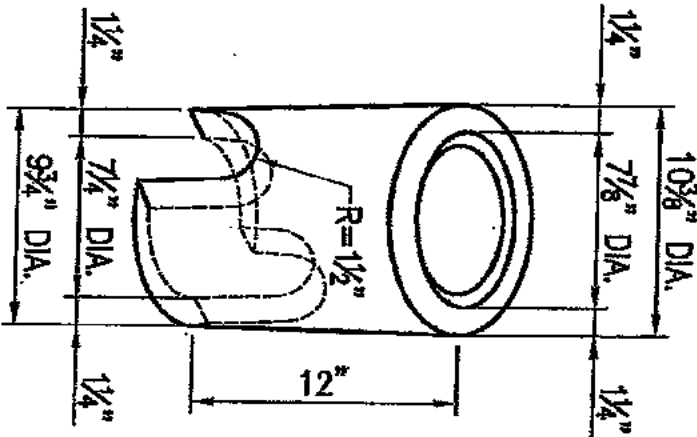

SECTION OF COVER

WEIGHT: = 6.6 lbs.

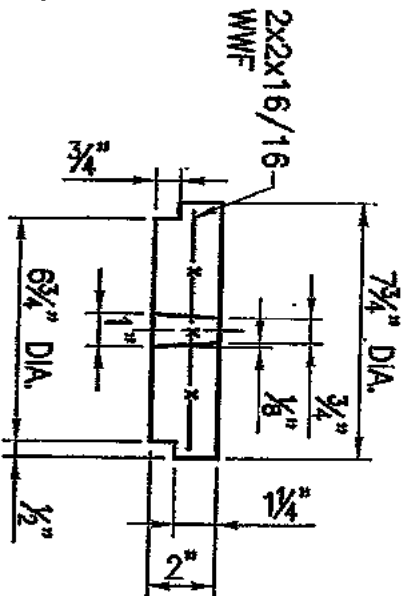
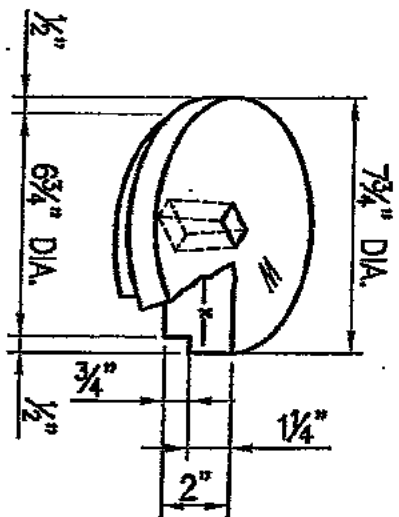

- NOTES:**
1. NON-REINFORCED
 2. ACCOMMODATES 1", 1 1/4" & 1 1/2" VALVES.
 3. PRODUCT NUMBER: BOX P2010, COVER P2011.



TYPE "B" METER BOX & CONCRETE COVER

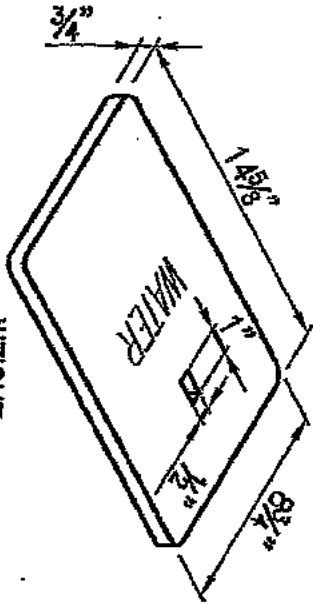
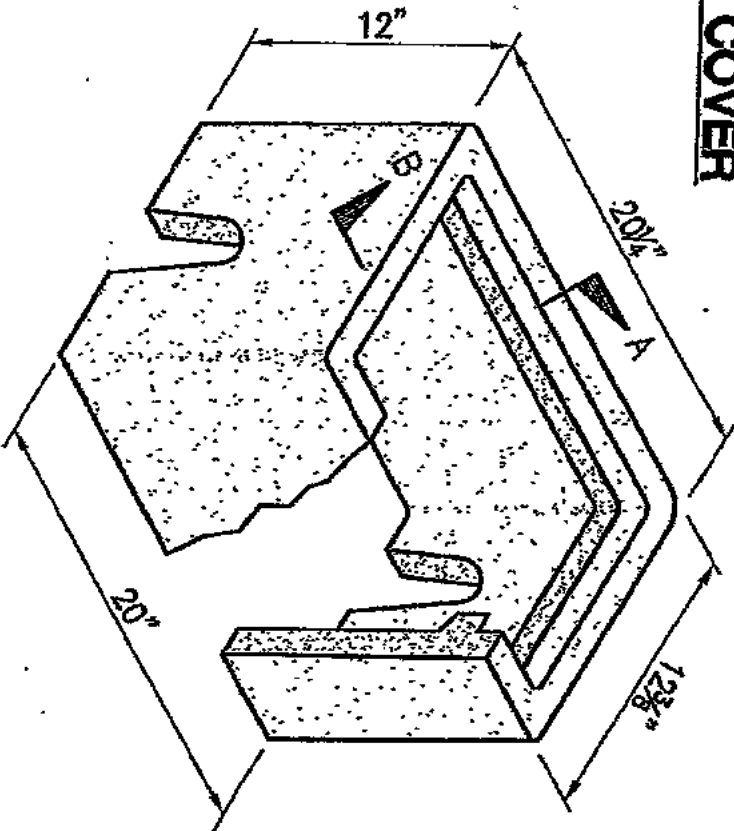
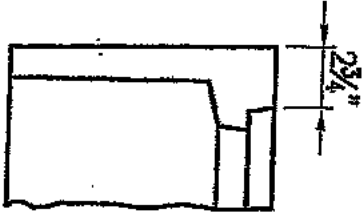
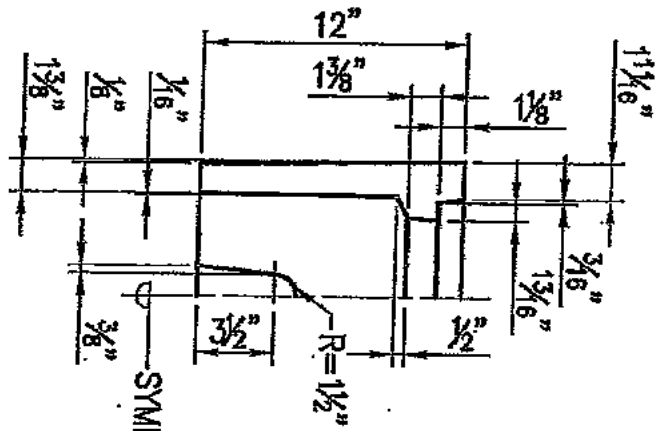

WEIGHT: = 14.2 lbs.

NOTES:

1. ACCOMMODATES 5/8" & 3/4" METERS.
2. SYNTHETIC FIBER REINFORCEMENT IN BOX AND COVER.
3. TYPE B VALVE BOX PRODUCT NO. P2012.
4. CONCRETE COVER, PRODUCT NO. 2013. TYPE B CAST IRON COVER, D&L MODEL NO. L-2440.
5. THIS COVER IS AVAILABLE WITH THE FOLLOWING BRANDS ON SPECIAL ORDERS: HTC, BMS HILD, GAS CO., GAS VALVE, TV, ELEC., TRAFFIC SIGNALS, CATV AND CO.

JENSON
PRECAST

TYPE "X" METER BOX

WT. = 107 LBS.

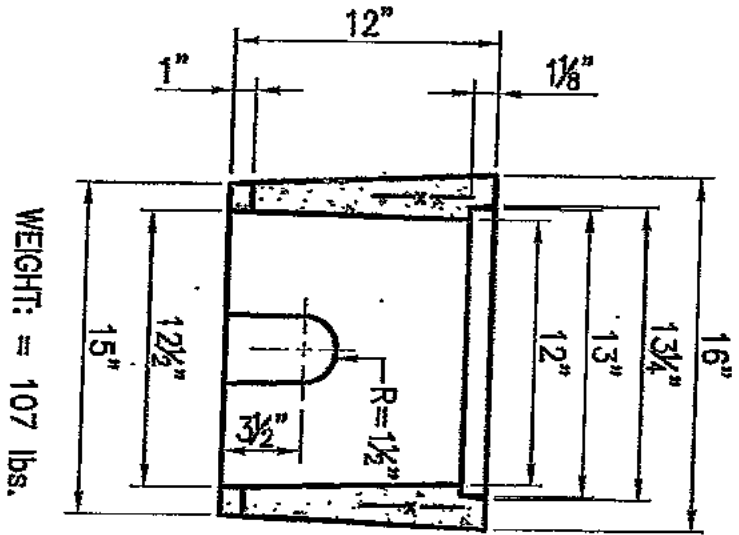

WEIGHT: = 107 lbs.

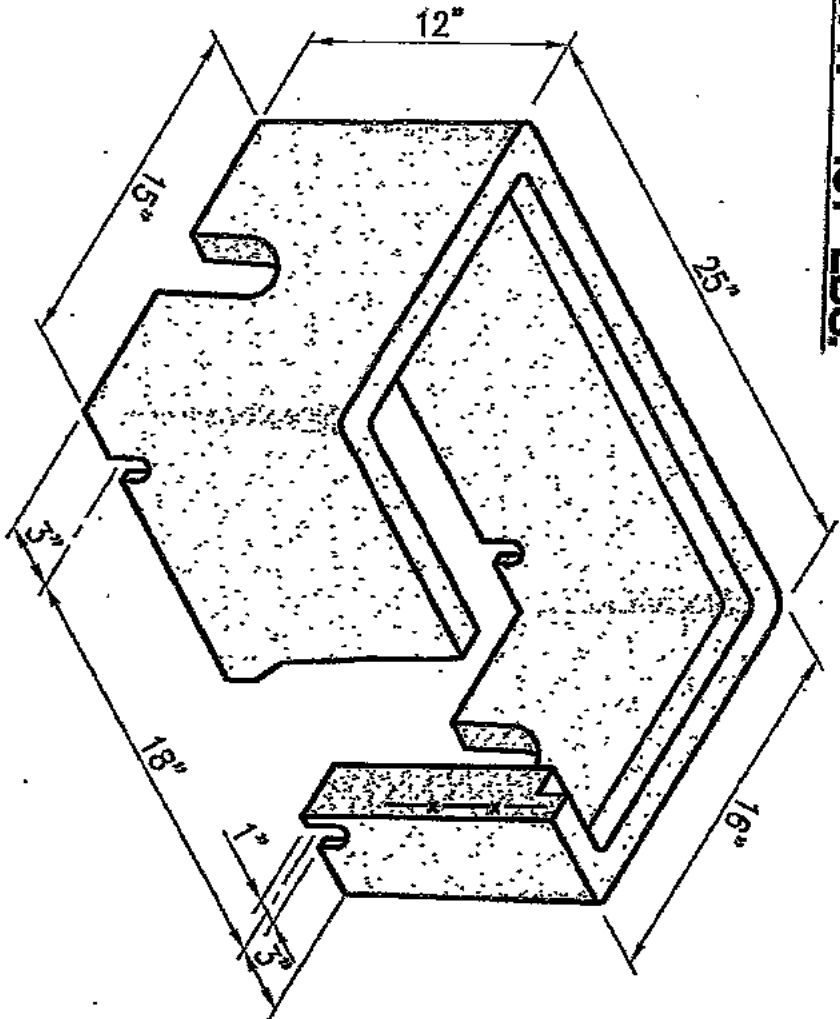

NOTES:

1. TYPE "X" METER BOX FOR 3/8", 3/4", AND 1" METERS.
2. FOR "HAWAII", TYPE "X" METER BOX IS FOR 1" METER ONLY.
3. CAST IRON COVER WITH CAST IRON READING COVER, D&L NO. L-2450.
4. REINFORCED WITH 2" x 2" - 16/16 GA. WELDED WIRE MESH AND SYNTHETIC FIBER REINFORCEMENT.

JENISANT
PRECAST

BOARD OF WATER SUPPLY

CITY AND COUNTY OF HONOLULU
630 SOUTH BERETANIA STREET
HONOLULU, HI 96843



December 14, 2012

PETER B. CARLISLE, MAYOR

DUANE R. MIYASHIRO, Chairman
MAHEALANI CYPHER, Vice Chair
THERESIA C. McMURDO
ADAM C. WONG
KAULANA H. R. PARK

KENNETH A. SHIMIZU, Ex-Officio
GLENN M. OKIMOTO, Ex-Officio

ERNEST Y. W. LAU, P.E.
Manager and Chief Engineer

ELLEN E. KITAMURA, P.E.
Deputy Manager and Chief Engineer *ek*

TO: WHOM IT MAY CONCERN

FROM: ERNEST Y. W. LAU, P.E.
MANAGER AND CHIEF ENGINEER *eyw*

SUBJECT: AMENDMENT TO THE WATER SYSTEM STANDARDS DATED 2002
FOR POLYETHYLENE (PE) PIPE FOR OAHU ONLY

Effective immediately, the Honolulu Board of Water Supply (BWS) rescinds approval of the incorporation of PE pipe into the municipal water system for the island of **Oahu only**. All service laterals and service connections 2-1/2 inches and smaller shall be copper pipe only unless otherwise approved by the BWS.

If you have any questions, please contact Michael Domion at (808)748-5740.

cc: Kauai Department of Water Supply
Maui Department of Water Supply
Hawaii Department of Water Supply

BOARD OF WATER SUPPLY

CITY AND COUNTY OF HONOLULU
630 SOUTH BERETANIA STREET
HONOLULU, HI 96843



June 5, 2012

PETER B. CARLISLE, MAYOR

RANDALL Y. S. CHUNG, Chairman
MAHEALANI CYPHER, Vice Chair
THERESIA C. McMURDO
DUANE R. MIYASHIRO
ADAM C. WONG

WESTLEY K.C. CHUN, Ex-Officio
GLENN M. OKIMOTO, Ex-Officio

ERNEST Y. W. LAU, P.E.
Manager and Chief Engineer

ELLEN E. HIRAYAMA, P.E.
Deputy Manager and Chief Engineer

TO: WHOM IT MAY CONCERN

FROM: ERNEST Y. W. LAU, P.E. 
MANAGER AND CHIEF ENGINEER

SUBJECT: MODIFICATIONS TO NSF STANDARD 61 AFFECTING MATERIALS
APPROVALS FOR BRASS PRODUCTS FOR OAHU ONLY

Effective July 1, 2012, the requirements of NSF Standard 61 Annex F reduce the allowable limit for lead extracted from test bodies from 15 parts per billion (ppb) to 5 ppb. As all waterworks brass fittings must conform to NSF Standard 61 in accordance with Section 211 – Brass Products of the Water System Standards, all materials approvals for brass fittings will be rescinded upon the Annex F effective date for Oahu only, unless certification is provided that products are in conformance with the updated NSF Standard.

Construction projects that have received approval for their brass product materials submittals prior to July 1, 2012 shall not be affected. Until conforming brass products are approved for inclusion on the Approved Materials List, brass products must be submitted for review and approval on a project-to-project basis.

If you have any questions, please contact Michael Domion at (808)748-5740.

cc: Kauai Department of Water Supply
Maui Department of Water Supply
Hawaii Department of Water Supply

BOARD OF WATER SUPPLY

CITY AND COUNTY OF HONOLULU
630 SOUTH BERETANIA STREET
HONOLULU, HI 96843



May 14, 2012

PETER B. CARLISLE, MAYOR

RANDALL Y. S. CHUNG, Chairman
MAHEALANI CYPHER, Vice Chair
THERESIA C. McMURDO
DUANE R. MIYASHIRO
ADAM C. WONG

WESTLEY K.C. CHUN, Ex-Officio
GLENN M. OKIMOTO, Ex-Officio

ERNEST Y. W. LAU, P.E.
Manager and Chief Engineer

ELLEN E. HIRAYAMA, P.E.
Deputy Manager and Chief Engineer

Mr. Wally Sunnaa, P.E.
Armorcast Products Company
13230 Saticoy Street
North Hollywood, California 91605

Dear Mr. Sunnaa,

Subject: Your Letter Dated November 18, 2011 Regarding Product Approval Request
for Polymer Concrete Type "A" Valve Box

We approve the Armorcast Polymer Concrete Type "A" Valve Box (drawing no. A6000712TA) for inclusion into the Water System Standards for Oahu only.

If you have any questions, please contact Michael Domion at (808)748-5740.

Very truly yours,

ERNEST Y. W. LAU, P.E.
Manager and Chief Engineer

Enclosure

cc: Kauai Department of Water Supply
Maui Department of Water Supply
Hawaii Department of Water Supply

APPROX. BOX WT. = 18 LBS.
 APPROX. COVER WT. = 8 LBS.

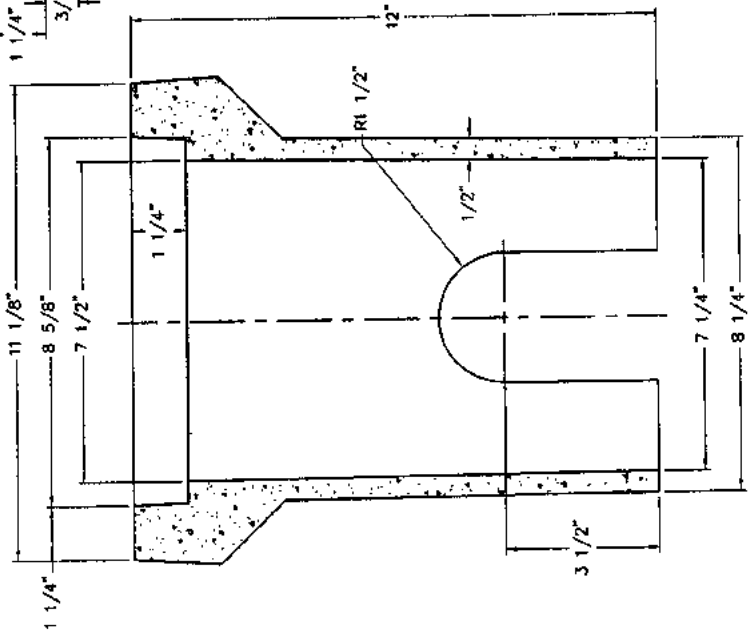
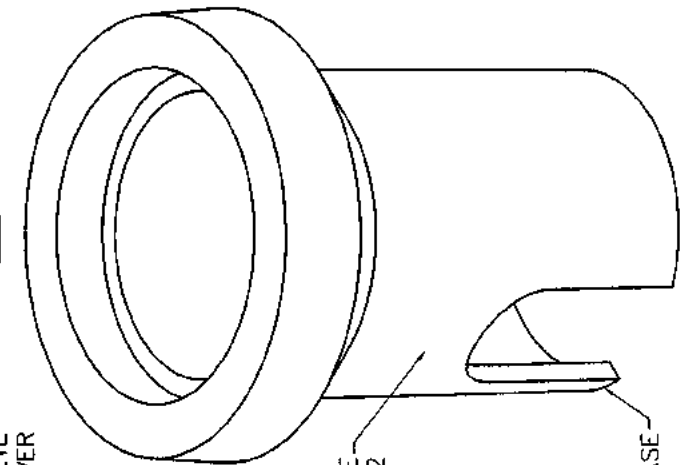
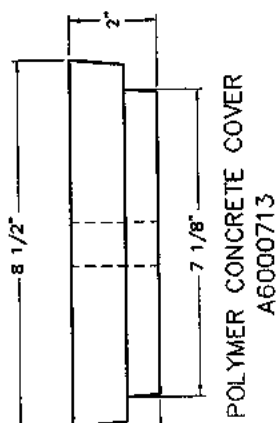
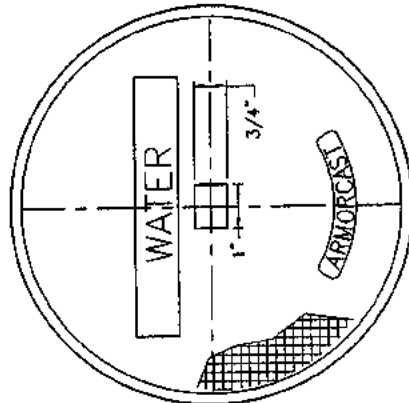
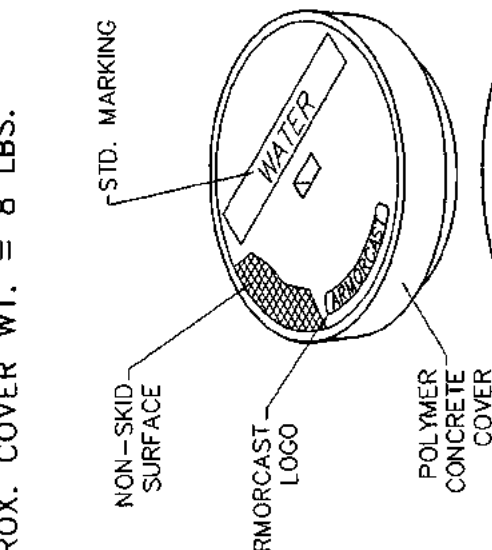

TYPE "A" VALVE BOX

12250 Salsbery Street, Northridge, CA 91320 (818) 942-3800 ARMORCAST PRODUCTS COMPANY		9" X 12" POLYMER CONCRETE TYPE A VALVE BOX OAHU BOARD OF WATER SUPPLY SCALE: 20X DATE: 12/11/11 DRAWN BY: WS CHECKED BY: WS PROJECT: POLYMER CONCRETE A6000712TA
---	--	--

BOARD OF WATER SUPPLY

CITY AND COUNTY OF HONOLULU
630 SOUTH BERETANIA STREET
HONOLULU, HI 96843



November 9, 2011

PETER B. CARLISLE, MAYOR

RANDALL Y. S. CHUNG, Chairman
DENISE M. C. DE COSTA, Vice Chair
THERESIA C. McMURDO
DUANE R. MIYASHIRO
ADAM C. WONG

WESTLEY K.C. CHUN, Ex-Officio
GLENN M. OKIMOTO, Ex-Officio

DEAN A. NAKANO
Acting Manager

Mr. John Nelson, Area Manager
Romac Industries, Inc.
21919 20th Avenue, SE, Suite 100
Bothell, Washington 98021

Dear Mr. Nelson:

Subject: Your Letter Dated May 6, 2011 Requesting Approval of Romac Style Macro
Extended Range Coupling

We approve the Romac Macro Extended Range Coupling for inclusion into the Water System Standards for Oahu only.

If you have any questions, please contact Michael Domion at (808)748-5740.

Sincerely,

DEAN A. NAKANO
Acting Manager

cc: Maui, Kauai, and Hawaii Department of Water Supply



**ROMAC
INDUSTRIES,
INC.**

21919 20th Avenue SE • Suite 100
Bothell, WA 98021

May 6, 2011

Jason H. Takaki, P.E.
Civil Engineer, Capital Projects Division
Honolulu Board of Water Supply
630 South Beretania Street
Honolulu, Hawaii 96843

Dear Mr. Takaki:

Romac Industries, Inc. would like to submit for approval the following items to be added to the approved material list for the Board of Water Supply.

Romac Style Macro Extended Range Coupling

Product Submittal:
(Enclosed)

The Macro is an Extended Range Coupling for multipurpose use, having a range from steel pipe through class 200 asbestos cement pipe.

Samples of this product have been sent to Operations, attention Daryl Hiromoto, for evaluation.

Please call me if you require additional information or have any further questions. Thank you for taking the time to consider our product for approval.

Sincerely Yours,

John Nelson
Area Manager
Romac Industries, Inc.

c.c.
Daryl Hiromoto
Peter Schmidt

BWS - ENGINEERING
2011 MAY 11 A 7:24

BOARD OF WATER SUPPLY

CITY AND COUNTY OF HONOLULU
630 SOUTH BERETANIA STREET
HONOLULU, HI 96843



September 14, 2011

PETER B. CARLISLE, MAYOR

RANDALL Y. S. CHUNG, Chairman
DENISE M. C. DE COSTA, Vice Chair
THERESIA C. McMURDO
DUANE R. MIYASHIRO
ADAM C. WONG

WESTLEY K.C. CHUN, Ex-Officio
GLENN M. OKIMOTO, Ex-Officio

DEAN A. NAKANO
Acting Manager

Mr. Jon A. Franzmeier
Hawaii Irrigation Supply Company, Inc.
803 Mapunapuna Street
Honolulu, Hawaii 96819-2038

Dear Mr. Franzmeier:

Subject: Your Letter Dated June 30, 2011 Requesting Confirmation of Approval for IPEX DR18 and DR14 C-900 4-inch Through 12-Inch PVC Pipe

We approve the IPEX Blue Brute, AWWA C900 PVC Pipes, DR18 and DR14, sizes 4-inch through 12-inch, for inclusion into the Water System Standards for Oahu only.

The approval is based on the original approval given to Johns-Manville PVC pipe, dated January 30, 1980.

The design and construction of the IPEX PVC pipes shall be as specified in our Water System Standards.

If you have any questions, please contact Michael Domion at 748-5740.

Sincerely,

DEAN A. NAKANO
Acting Manager

cc: Hawaii, Maui, and Kauai Water Departments

BOARD OF WATER SUPPLY

CITY AND COUNTY OF HONOLULU
630 SOUTH BERETANIA STREET
HONOLULU, HI 96843



July 15, 2011

PETER B. CARLISLE, MAYOR

RANDALL Y. S. CHUNG, Chairman
DENISE M. C. DE COSTA
ANTHONY R. GUERRERO, JR.
THERESIA C. McMURDO
ADAM C. WONG

WESTLEY K.C. CHUN, Ex-Officio
GLENN M. OKIMOTO, Ex-Officio

DEAN A. NAKANO
Acting Manager

TO: WHOM IT MAY CONCERN

FROM: DEAN A. NAKANO, ACTING MANAGER
BOARD OF WATER SUPPLY

SUBJECT: AMENDMENT TO THE WATER SYSTEM STANDARDS, DATED 2002,
FOR CONCRETE CYLINDER PIPE AND FITTINGS

Effective immediately, the Honolulu Board of Water Supply herewith rescinds approval of the incorporation of concrete cylinder pipe (CCP) into the municipal water system for the island of Oahu only. Concrete cylinder fittings shall only be used for connections to existing CCP.

Historical data indicates CCP is not cost-effective based on expected service life. CCP is also difficult and time-consuming to repair.

If you have any questions, please contact Michael Domion at (808)748-5740.

BOARD OF WATER SUPPLY

CITY AND COUNTY OF HONOLULU
630 SOUTH BERETANIA STREET
HONOLULU, HI 96843



April 29, 2011

PETER B. CARLISLE, MAYOR

RANDALL Y. S. CHUNG, Chairman
DENISE M. C. DE COSTA
ANTHONY R. GUERRERO, JR.
THERESA C. McMURDO
ADAM C. WONG

WESTLEY K.C. CHUN, Ex-Officio
GLENN M. OKIMOTO, Ex-Officio

WAYNE M. HASHIRO, P.E.
Manager and Chief Engineer

DEAN A. NAKANO
Deputy Manager

Royal Pipe Systems
131 Regalcrest Court
Woodbridge, ON, Canada
L4L 8P3

Gentlemen:

Subject: Rescinding Approvals for Royal Pipe Systems PVC Pressure Pipe

Effective immediately, the Honolulu Board of Water Supply (BWS) herewith rescinds approval letters dated December 14, 2001 and May 19, 2003, for Royal Pipe System PVC pressure pipes for use on the island of Oahu.

The BWS experienced premature failure of a 12-inch PVC pipe installed in 2003. The PVC main shattered, causing extensive damage to the roadway, property damage, interruption of business and heavy traffic conditions. We could not determine the cause of the failure, and approximately 17 feet of main was needed to repair the break. The rescinding of your approvals is a precautionary measure as we further investigate the cause of the break.

If you have any questions, please contact Michael Domion at (808) 748-5740.

Sincerely,

DEAN A. NAKANO
Acting Manager

Enclosures

cc: Kauai, Maui, Hawaii Water Departments

BOARD OF WATER SUPPLY

CITY AND COUNTY OF HONOLULU
630 SOUTH BERETANIA STREET
HONOLULU, HI 96843



November 4, 2010

PETER B. CARLISLE, MAYOR

RANDALL Y. S. CHUNG, Chairman
ANTHONY R. GUERRERO, JR.
WILLIAM K. MAHOE
THERESIA C. McMURDO
ADAM C. WONG

GEORGE "KEOKI" MIYAMOTO, Ex-Officio
MICHAEL D. FORMBY, Ex-Officio

WAYNE M. HASHIRO, P.E.
Manager and Chief Engineer

DEAN A. NAKANO
Deputy Manager

Mr. Gary Kong
Delco Sales
111 Sand Island Access Road, Unit I-10
Honolulu, Hawaii 96819

Dear Mr. Kong:

Subject: Your Letter Dated July 29, 2010, Requesting
Approval of Fluor O Kote #1 Fasteners

We approve the METCO Fluor O Kote #1 Blue Bolts for inclusion into the Water System Standards for Oahu only, for mechanical joint installations.

If you have any questions, please contact Michael Domion at 748-5740.

Me ka mahalo pumehana,

WAYNE M. HASHIRO, P.E.
Manager and Chief Engineer

cc: Maui, Kauai, and Hawaii Department of Water Supply

BOARD OF WATER SUPPLY

CITY AND COUNTY OF HONOLULU
630 SOUTH BERETANIA STREET
HONOLULU, HI 96843



May 6, 2010

MUFI HANNEMANN, Mayor

RANDALL Y. S. CHUNG, Chairman
SAMUEL T. HATA
WILLIAM K. MAHOE
THERESIA C. McMURDO
ADAM C. WONG

JEFFREY S. CUDIAMAT, Ex-Officio
BRENNON T. MORIOKA, Ex-Officio

WAYNE M. HASHIRO, P.E.
Manager and Chief Engineer

DEAN A. NAKANO
Deputy Manager

Mr. Gary Kong
Delco Sales
111 Sand Island Access Road, Unit I-10
Honolulu, Hawaii 96819

Dear Mr. Kong:

Subject: Your Letter Dated September 29, 2009, Requesting Approval of Advance Products and Systems Full-Face Trojan Nitrile Gasket

We approve the Advance Products and Systems Full-Face Trojan Nitrile Gasket for inclusion into the Water System Standards for Oahu only.

If you have any questions, please contact Michael Domion at 748-5740.

Sincerely,

WAYNE M. HASHIRO, P.E.
Manager and Chief Engineer

cc: Maui, Kauai, and Hawaii Department of Water Supply

BOARD OF WATER SUPPLY

CITY AND COUNTY OF HONOLULU
630 SOUTH BERETANIA STREET
HONOLULU, HI 96843



January 19, 2010

MUFI HANNEMANN, Mayor

RANDALL Y. S. CHUNG, Chairman
SAMUEL T. HATA
ALLY J. PARK
ROBERT K. CUNDIFF
WILLIAM K. MAHOE

JEFFREY S. CUDIAMAT, Ex-Officio
BRENNON T. MORIOKA, Ex-Officio

WAYNE M. HASHIRO, P.E.
Manager and Chief Engineer

DEAN A. NAKANO
Deputy Manager and Chief Engineer

Mr. Rich Varalla
V.P. Sales & Marketing
Tripac Fasteners, A Division of Tripac Marketing, Inc.
475 Klug Circle
Corona, California 92880-5406

Dear Mr. Varalla:

Subject: Your Letter Dated May 20, 2009, Regarding Approval of
Garlock/Tripac Style 5000 Compressed Non-Asbestos Gasket

We approve the Garlock/Tripac Style 5000 gaskets for inclusion into our Water System Standards.

If you have any questions, please contact Michael Domion at (808)748-5740.

Sincerely,

WAYNE M. HASHIRO, P.E.
Manager and Chief Engineer

cc: Maui, Kauai, and Hawaii Department of Water Supply

BOARD OF WATER SUPPLY

CITY AND COUNTY OF HONOLULU
630 SOUTH BERETANIA STREET
HONOLULU, HI 96843



November 10, 2009

MUFI HANNEMANN, Mayor

RANDALL Y. S. CHUNG, Chairman
SAMUEL T. HATA
ALLY J. PARK
ROBERT K. CUNDIFF
WILLIAM K. MAHOE

JEFFREY S. CUDIAMAT, Ex-Officio
BRENNON T. MORIOKA, Ex-Officio

WAYNE M. HASHIRO, P.E.
Manager and Chief Engineer

DEAN A. NAKANO
Deputy Manager and Chief Engineer

Mr. Gary Kong
Delco Sales
111 Sand Island Access Road I-10
Honolulu, Hawaii 96819

Mr. Kong:

Subject: Your Letter Dated June 25, 2009 Requesting Inclusion of North American Pipe Corporation's PVC Pipes into the Approved Materials List for Oahu Only

We grant approvals as follows for the inclusion of North American Pipe Corporation's PVC pipes in the Water System Standards (WSS) Approved Materials List for Oahu only:

PVC C-900 Pipe

Dimension Ratio (DR)	Nominal Pipe Size	
14	4-inch	Approved
14	6-inch	Approved
14	8-inch	Approved
14	10-inch	Not approved
14	12-inch	Approved
18	4-inch	Approved
18	6-inch	Approved
18	8-inch	Approved
18	10-inch	Not approved
18	12-inch	Approved

Note: The 10-inch diameter PVC pipe is not a standard size specified in the WSS and is not approved for use.

PVC Schedule 40 Pipe is not included in the WSS Approved Materials List. Schedule 40 PVC pipe must meet the material specifications for irrigation pressure lines per Division 300, Section 307.02.C.2 and is considered for use on a job-to-job basis only.

Mr. Gary Kong
November 10, 2009
Page 2

PVC C-905 Pipe

Dimension Ratio (DR)	Nominal Pipe Size	
18	14-inch	Not approved
18	16-inch	Approved
18	18-inch	Not approved
18	20-inch	Approved
18	24-inch	Approved

Note: The 14-inch diameter PVC pipe is not a standard size specified in the WSS and is not approved for use. The 18-inch diameter PVC pipe size is also not approved for use on Oahu in accordance with the WSS.

If you have any questions, please contact Michael Domion at 748-5740.

Sincerely,

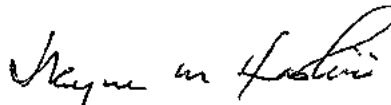

WAYNE M. HASHIRO, P.E.
Manager and Chief Engineer

BOARD OF WATER SUPPLY

CITY AND COUNTY OF HONOLULU
630 SOUTH BERETANIA STREET
HONOLULU, HI 96843



October 27, 2009

MUFI HANNEMANN, Mayor

RANDALL Y. S. CHUNG, Chairman
SAMUEL T. HATA
ALLY J. PARK
ROBERT K. CUNDIFF
WILLIAM K. MAHOE

JEOFFREY S. CUDIAMAT, Ex-Officio
BRENNON T. MORIOKA, Ex-Officio

WAYNE M. HASHIRO, P.E.
Manager and Chief Engineer

DEAN A. NAKANO
Deputy Manager and Chief Engineer

Mr. Gary Kong
Delco Sales
111 Sand Island Access Road, I-10
Honolulu, Hawaii 96819

Dear Mr. Kong:

Subject: Your Letter Dated June 25, 2009 Requesting Approval of Delco Multi Fittings

We approve the Blue Brute pressure fittings in sizes from 4-Inch to 8-Inch conforming to AWWA C907 for inclusion into our Water System Standards (WSS) for Oahu only.

We deny approval of the CycleTough IPS Pressure Fittings. The product does not conform to AWWA C907 as required by the WSS.

If you have any questions, please contact Michael Domion at 748-5740.

Sincerely,

WAYNE M. HASHIRO, P.E.
Manager and Chief Engineer

cc: Maui, Kauai and Hawaii Department of Water Supply

BOARD OF WATER SUPPLY

CITY AND COUNTY OF HONOLULU
630 SOUTH BERETANIA STREET
HONOLULU, HI 96843



August 14, 2009

MUFI HANNEMANN, Mayor

RANDALL Y. S. CHUNG, Chairman
SAMUEL T. HATA
ALLY J. PARK
ROBERT K. CUNDIFF
WILLIAM K. MAHOE

JEFFREY S. CUDIAMAT, Ex-Officio
BRENNON T. MORIOKA, Ex-Officio

WAYNE M. HASHIRO, P.E.
Manager and Chief Engineer

DEAN A. NAKANO
Deputy Manager and Chief Engineer

Mr. Mark Wright
Diamond Plastics Corporation
1212 Johnstown Road
P. O. Box 1608
Grand Island, Nebraska 68802-1608

Dear Mr. Wright:

Subject: Your Letter Dated June 27, 2008 and Follow-up Facsimile Dated March 24, 2009, Requesting Inclusion of Diamond Plastics PVC Pipes Into the Approved Material List for Oahu Only

We approve the Diamond Plastics PVC pipes for the following classes, dimension ratios (DR) and sizes, for inclusion in our Water System Standards (WSS) for Oahu only:

<u>Class</u>	<u>Dimension Ratio (DR)</u>	<u>Size</u>
C900	14	4", 6", 8" and 12"
C900	18	4", 6", 8" and 12"
C905	18	16", 18", 20" and 24"

We do not use 10-inch and 14-inch nominal pipe sizes and these sizes are not approved for inclusion in our Water System Standards.

The 16-inch DR14 PVC pipe does not conform to our standards (Division 200, Section 204.01.C); therefore, will not be approved for inclusion in our standards under Division 400, Section 402.I.E – Approved Material List. However, we will consider the use of the 16-inch DR14 PVC pipe in our water system on a case-by-case basis.

We deny approval of the Diamond Lok-21 restrained joint C900 PVC pipes. Restrained joint is not permitted in our water system.

If you have any questions, please contact Michael Domion at (808)748-5740.

Sincerely,

WAYNE M. HASHIRO, P.E.
Manager and Chief Engineer

cc: Maui, Kauai, and Hawaii Department of Water Supply

BOARD OF WATER SUPPLY

CITY AND COUNTY OF HONOLULU
630 SOUTH BERETANIA STREET
HONOLULU, HI 96843



May 18, 2009

MUFI HANNEMANN, Mayor

RANDALL Y. S. CHUNG, Chairman
SAMUEL T. HATA
ALLY J. PARK
ROBERT K. CUNDIFF
WILLIAM K. MAHOE

JEFFREY S. CUDIAMAT, Ex-Officio
BRENNON T. MORIOKA, Ex-Officio

WAYNE M. HASHIRO, P.E.
Manager and Chief Engineer

DEAN A. NAKANO
Deputy Manager and Chief Engineer

TO: WHOM IT MAY CONCERN
Wayne M. Hashiro
FROM: WAYNE M. HASHIRO, P.E.
MANAGER AND CHIEF ENGINEER

SUBJECT: 2002 WATER SYSTEM STANDARDS AMENDMENTS

The following amendment to the 2002 Water System Standards is effective immediately for **OAHU ONLY**:

DIVISION 400, SECTION 403 STANDARD DETAILS:

Replace the following details with the enclosed details (2009 Revision):

<u>Standard Detail</u>	<u>Description</u>
M34	8" x 2" FM Meter & Box Layout Fire and Domestic Uses – CMU Walls
M35	8" x 2" FM Meter & Box Layout Fire and Domestic Uses – CMU Walls
M37	8" x 2" FM Meter & Box Layout Fire and Domestic Uses – Precast/Cast-In-Place Walls
M38	8" x 2" FM Meter & Box Layout Fire and Domestic Uses – Precast/Cast-In-Place Walls

The manhole rungs in the FM meter box have been relocated to the outlet side of the meter to improve access for maintenance by Board of Water Supply personnel. The sump will be located on the opposite side due to the relocation of the manhole rungs.

If you have any questions, please contact Michael Domion at 748-5740.

Enclosures

cc: Kauai, Maui, Hawaii Water Departments

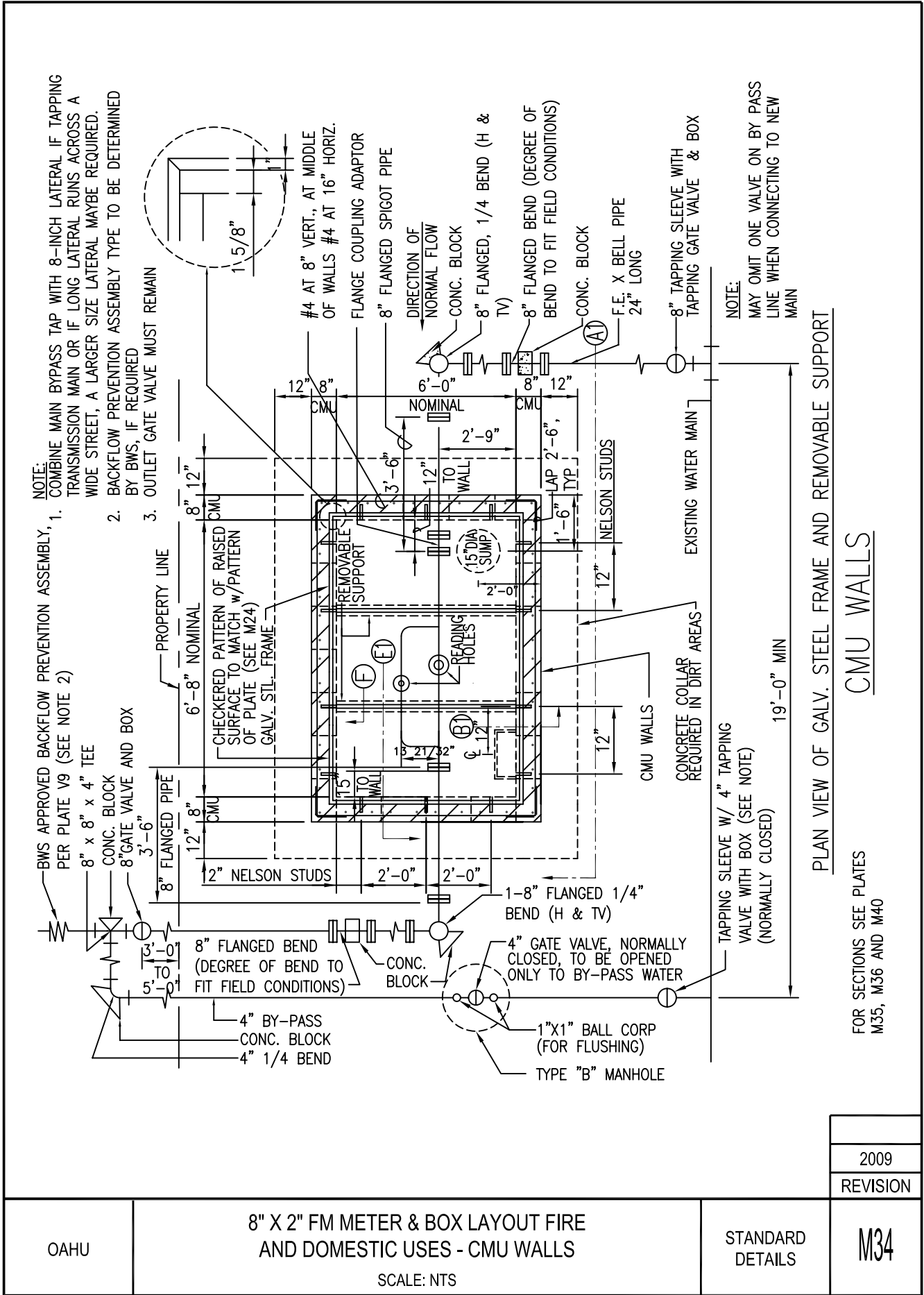

OAHU

8" X 2" FM METER & BOX LAYOUT FIRE AND DOMESTIC USES - CMU WALLS
 SCALE: NTS

STANDARD DETAILS

2009
REVISION
M34

NOTES FOR CMU WALL MANHOLE

1. BWS 3500 CONCRETE, 1500 PSI CMU AND GRADE 60 REINFORCING STEEL
2. DESIGN IS BASED ON: 250 PSF LIVE LOAD; 0 SURCHARGE; 60 PCF/FT AT REST PRESSURE; AND WATER TABLE BELOW BOTTOM SLAB; PER AASHTO LRFD BRIDGE DESIGN SPECIFICATION (1998) NON-TRAFFIC TYPE.
3. ALL CELLS SHALL BE GROUTED SOLID WITH 2500 PSI GROUT. TYPE M MORTAR
4. SPECIAL INSPECTION SHALL BE PROVIDED DURING CONSTRUCTION FOR CMU WALL.

NOTE:
REFER TO M36, M40, M41 AND
M42 FOR DETAILS.

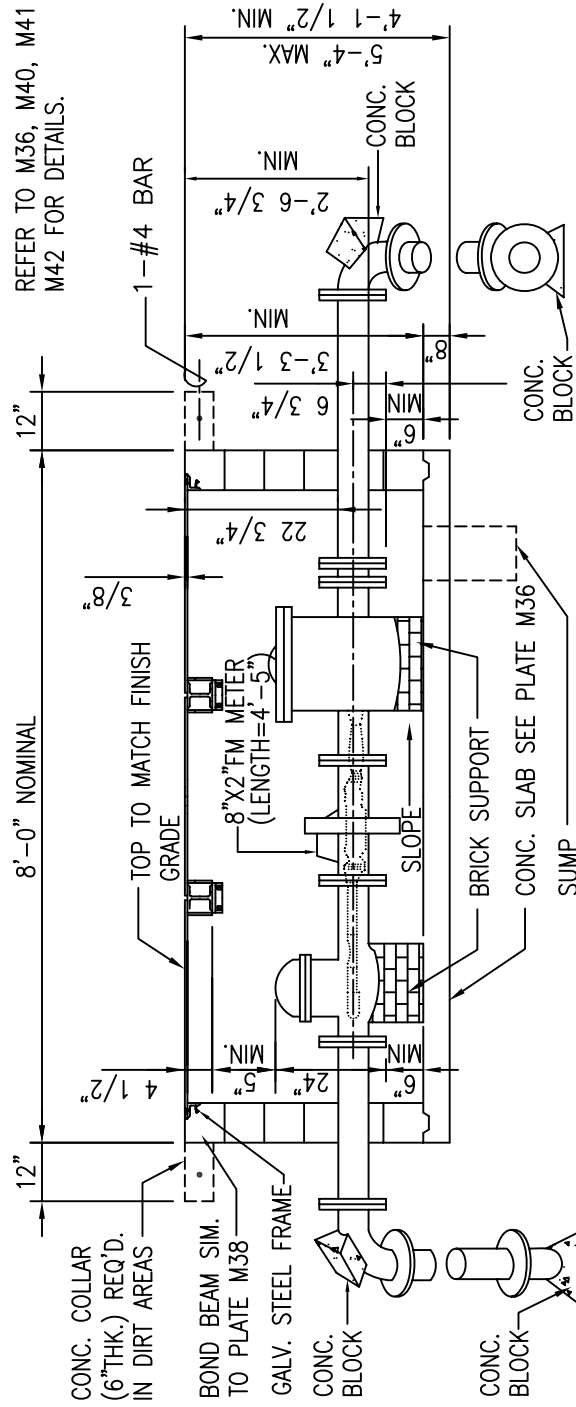

NOTE:
COMBINED DOMESTIC AND FIRE FLOW
REQUIREMENT = NOT TO EXCEED 3,500 GPM

SECTION "A1-A1"

CMU WALLS

2009
REVISION

OAHU

8" X 2" FM METER & BOX LAYOUT FIRE
AND DOMESTIC USES - CMU WALLS

SCALE: NTS

STANDARD
DETAILS

M35

- NOTE:**
1. COMBINE MAIN BYPASS TAP WITH 8-INCH LATERAL IF TAPPING TRANSMISSION MAIN OR IF LONG LATERAL RUNS ACROSS A WIDE STREET, A LARGER SIZE LATERAL MAYBE REQUIRED.
 2. BACKFLOW PREVENTION ASSEMBLY TYPE TO BE DETERMINED BY BWS, IF REQUIRED
 3. OUTLET GATE VALVE MUST REMAIN

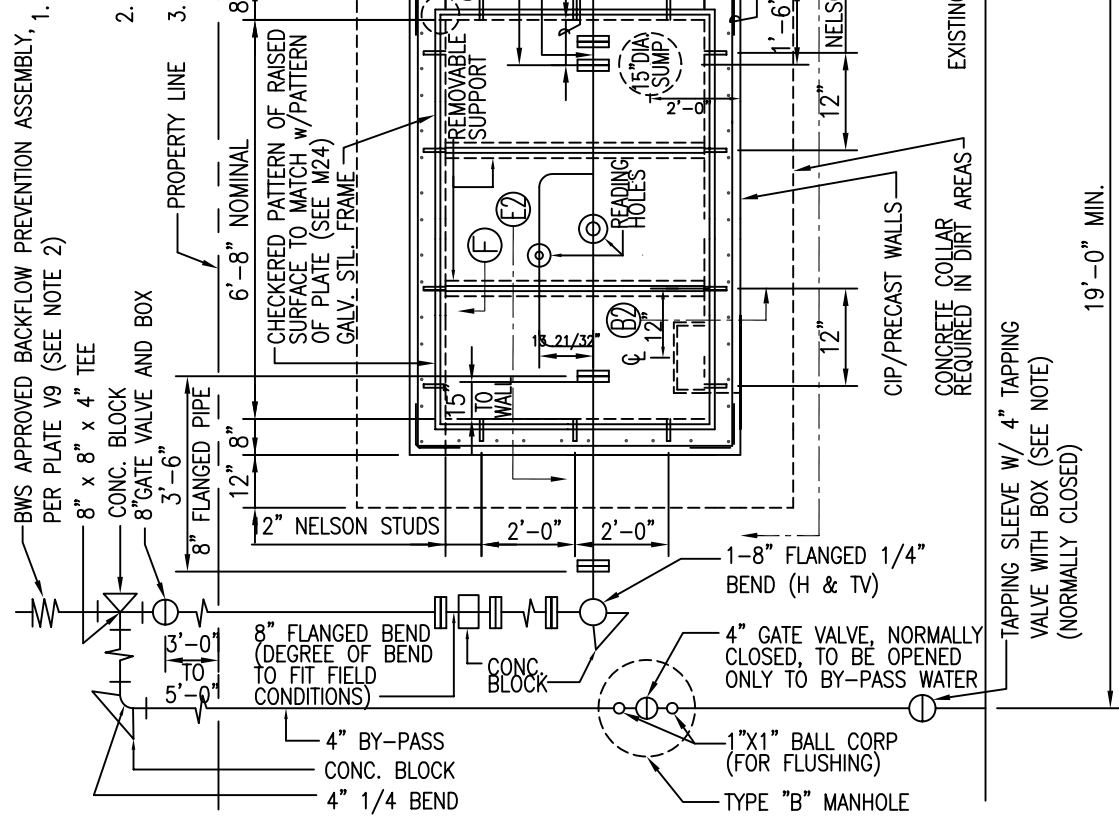

NOTE:
MAY OMIT ONE VALVE ON BY-PASS LINE WHEN CONNECTING TO NEW MAIN

PLAN VIEW OF GALV. STEEL FRAME AND REMOVABLE SUPPORT
PRECAST/CAST IN PLACE WALLS

FOR SECTIONS SEE
M38, M39 AND M40

OAHU	8" X 2" FM METER & BOX LAYOUT FIRE AND DOMESTIC USES - PRECAST / CAST-IN-PLACE WALLS	STANDARD DETAILS	M37
SCALE: NTS			REVISION
			2009

NOTES FOR PRECAST/CAST-IN-PLACE WALL MANHOLE

1. BWS 3500 CONCRETE AND GRADE 60 REINFORCING STEEL
2. DESIGN IS BASED ON: 250 PSF LIVE LOAD; 0 SURCHARGE; 60 PCF/FT AT REST PRESSURE; AND WATER TABLE BELOW BOTTOM SLAB, PER AASHTO LRFD BRIDGE DESIGN SPECIFICATION (1998). NON-TRAFFIC TYPE.

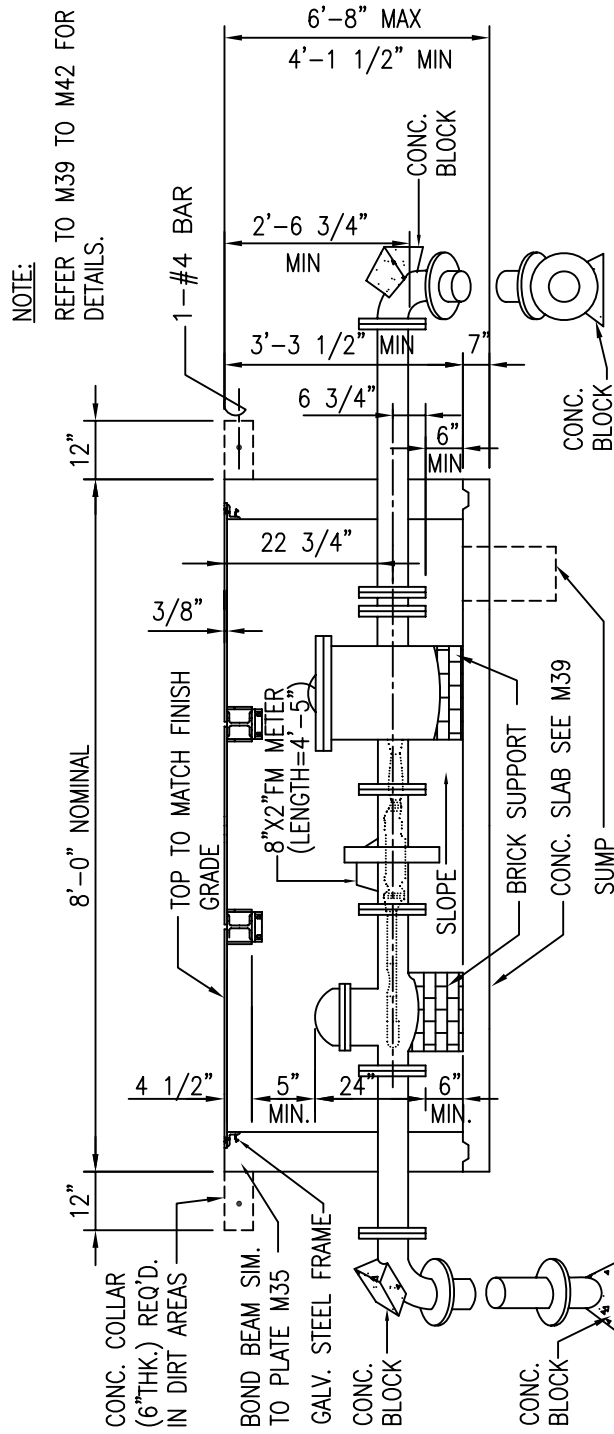

SECTION "A2-A2"
N.T.S.

PRECAST/CAST IN PLACE WALLS

OAHU

8" X 2" FM METER & BOX LAYOUT FIRE AND DOMESTIC USES -
PRECAST / CAST-IN-PLACE WALLS
SCALE: NTS

STANDARD
DETAILS

2009
REVISION

M38

BOARD OF WATER SUPPLY

CITY AND COUNTY OF HONOLULU
630 SOUTH BERETANIA STREET
HONOLULU, HI 96843



February 24, 2009

MUFI HANNEMANN, Mayor

RANDALL Y. S. CHUNG, Chairman
SAMUEL T. HATA
ALLY J. PARK
ROBERT K. CUNDIFF

JEFFREY S. CUDIAMAT, Ex-Officio
BRENNON T. MORIOKA, Ex-Officio

WAYNE M. HASHIRO, P.E.
Manager and Chief Engineer

DEAN A. NAKANO
Deputy Manager, and Chief Engineer

Mr. Mike McLeod, Vice President
Frank J. Martin Company
18424 Highway 99
Lynnwood, Washington 98037

Dear Mr. McLeod:

Subject: Your Letter Dated October 23, 2008, Requesting Approval of Polytubes High Density Polyethylene Copper Tube Sized Pipes

We approve the Polytubes High Density Polyethylene (HDPE) copper tube sized (CTS) 3/4-inch to 2-inches for inclusion into the Water System Standards. The Polytubes HDPE CTS pipes, which conform to the applicable requirements of the AWWA and ASTM Standards for polyethylene (PE) tubing, shall be used specifically between the meter and the property valve where indicated on the service lateral standard details for Oahu.

We apologize for the delay in our review and appreciate your patience. If you have any questions, please contact Michael Domion at (808)748-5740.

Sincerely,

WAYNE M. HASHIRO, P.E.
Manager and Chief Engineer

Supp

BOARD OF WATER SUPPLY

CITY AND COUNTY OF HONOLULU
630 SOUTH BERETANIA STREET
HONOLULU, HI 96843



December 31, 2008

MUFU HANNEMANN, Mayor

RANDALL Y. S. CHUNG, Chairman
SAMUEL T. HATA
ALLY J. PARK
ROBERT K. CUNDIFF
MARC C. TILKER

CRAIG I. NISHIMURA, Ex-Officio
BRENNON T. MORIOKA, Ex-Officio

CLIFFORD P. LUM, P.E.
Manager and Chief Engineer

DEAN A. NAKANO
Deputy Manager and Chief Engineer

TO: WHOM IT MAY CONCERN

FROM: 
DEAN A. NAKANO, DEPUTY MANAGER AND CHIEF ENGINEER
BOARD OF WATER SUPPLY

SUBJECT: 2002 WATER SYSTEM STANDARDS AMENDMENTS

In response to the City and County of Honolulu, Department of Planning and Permitting new minimum utility depth policy (Engineering and Policy Memorandum No. CEB-1-08), the following amendments to the 2002 Water System Standards are effective immediately for Oahu only:

Division 100, Section 102 MAINS, Subsection 102.03 COVER:

Delete Table 100-3 – COVER FOR WATER MAINS (FEET) and replace with the following:

Table 100-3 - COVER FOR WATER MAINS (FEET)							
Island	Minimum Cover for Pipe Diameter Indicated ^a						Maximum ^b For All Mains
	Smaller Than 4-Inch	4-Inch	6-Inch	8-Inch	12-Inch	Larger Than 12-Inch	
Oahu	3.0 ^c	3.0	3.0	3.0	3.0	3.0	8
Hawaii	1.5	2.0	2.0	2.0	2.5	3.0	5
Kauai	3.0	3.0	3.0	3.0	3.0	3.0	8
Maui	N/A	2.5	3.0	3.0	3.0	3.0	5

- a - Minimum cover for mains and laterals to be installed in State rights-of-way shall be 3 feet.
- b - Over maximum cover requires Manager's approval and concrete jacketing of pipe.
- c - Minimum cover for laterals located within the curb & gutter and sidewalk areas in the City rights-of-way shall be 18-inch.

Division 400, Section 403 STANDARD DETAILS:

Replace the following details with the enclosed details (2008 Revision):

<u>Standard Detail</u>	<u>Description</u>
L13	Copper Service Lateral for Connection Type "X" Meter Box 5/8", 3/4", & 1" Meters
L15	Copper Service Lateral for Connection Type III Meter Box 1-1/2" & 2" Meters
L20	Typical Detail for Installation of Ball Stop After Meter
L21	New Lateral Installation Schematic Detail
L22	Lateral Reconnection Schematic Detail

If you have any questions, please contact Michael Domion at 748-5740.

cc: Kauai, Maui, Hawaii Water Departments

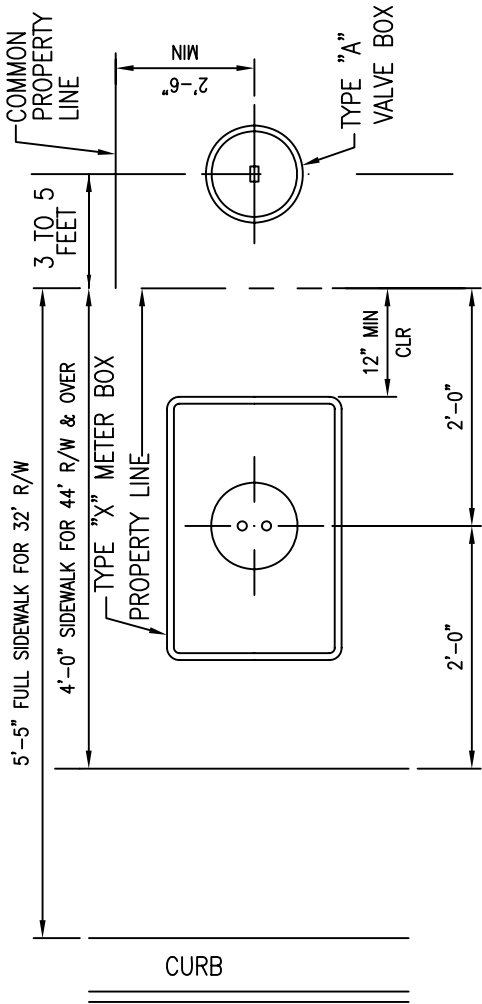

NOTES:

1. 3 FEET MINIMUM COVER FOR SIDEWALK, CURB & GUTTER AREAS FOR STATE R-O-W ONLY.
2. SEE PLATE L17 FOR MATERIAL SCHEDULE.

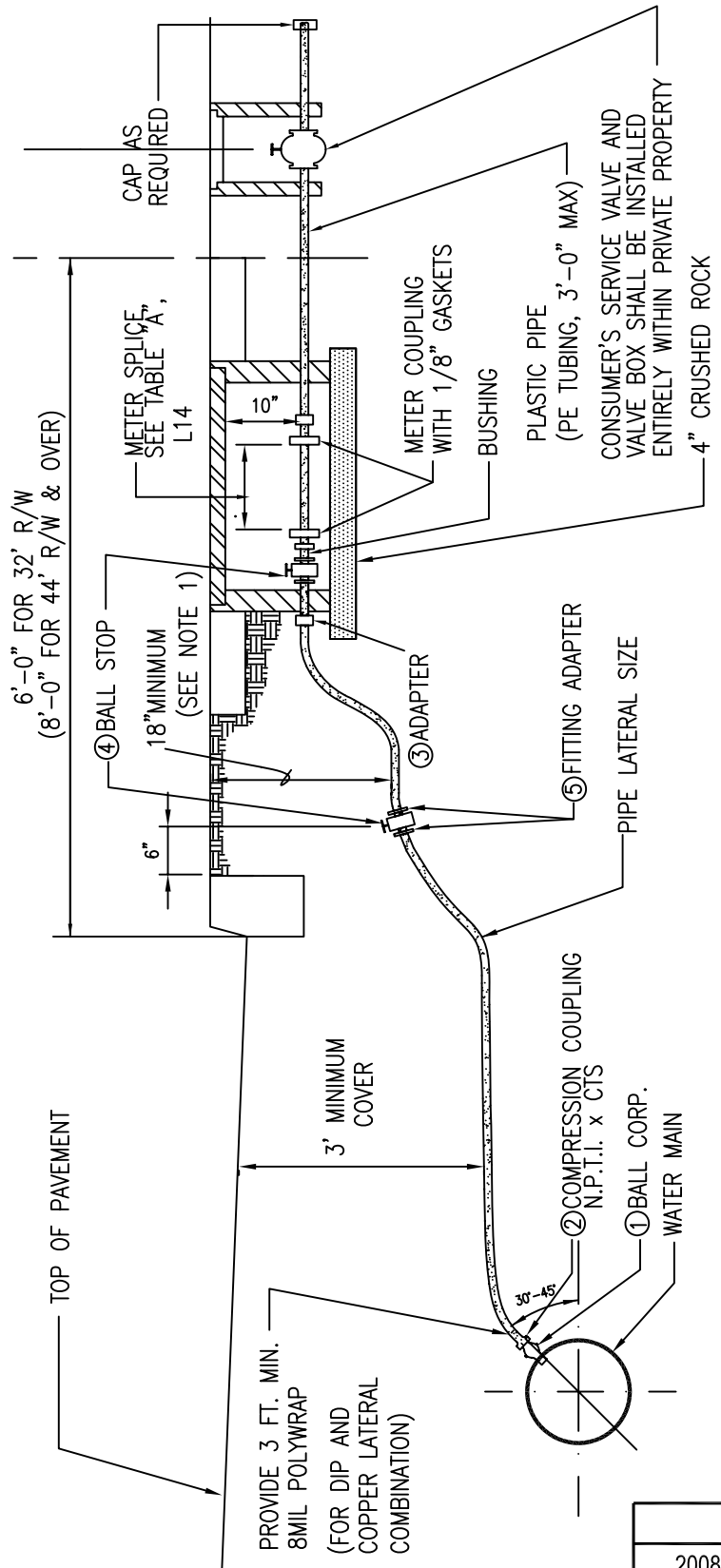

SCALE: NTS

COPPER SERVICE LATERAL FOR CONNECTION TYPE "X" METER BOX 5/8", 3/4", & 1" METERS

SCALE: NTS

2008
REVISION

OAHU

STANDARD DETAILS

L13

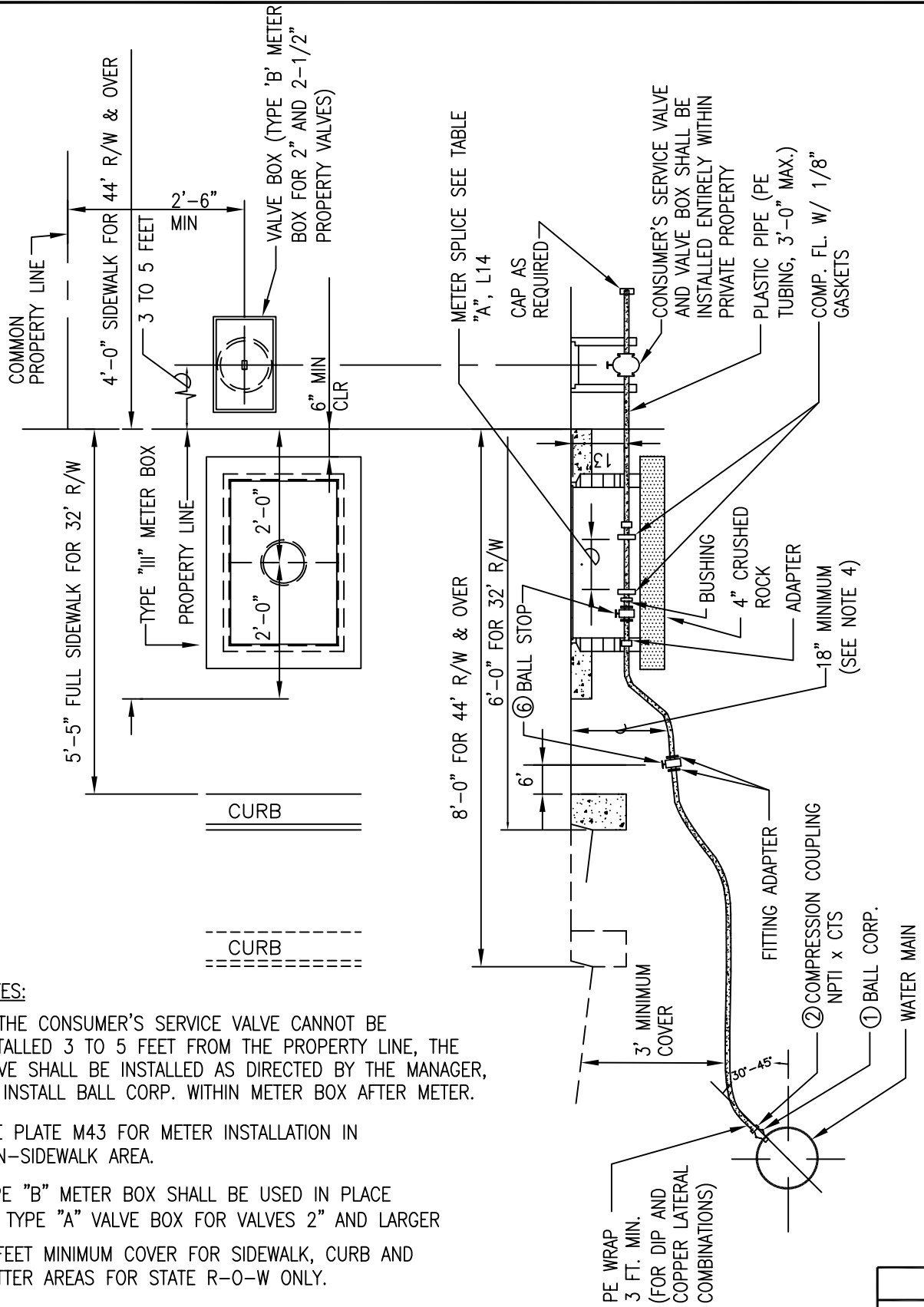

NOTES:

1. IF THE CONSUMER'S SERVICE VALVE CANNOT BE INSTALLED 3 TO 5 FEET FROM THE PROPERTY LINE, THE VALVE SHALL BE INSTALLED AS DIRECTED BY THE MANAGER, OR INSTALL BALL CORP. WITHIN METER BOX AFTER METER.
2. SEE PLATE M43 FOR METER INSTALLATION IN NON-SIDEWALK AREA.
3. TYPE "B" METER BOX SHALL BE USED IN PLACE OF TYPE "A" VALVE BOX FOR VALVES 2" AND LARGER
4. 3 FEET MINIMUM COVER FOR SIDEWALK, CURB AND GUTTER AREAS FOR STATE R-0-W ONLY.
5. SEE PLATE L17 FOR MATERIAL SCHEDULE.

OAHU	COPPER SERVICE LATERAL FOR CONNECTION TYPE III METER BOX 1 1/2" & 2" METERS SCALE: NTS	STANDARD DETAILS	2008
			REVISION
			L15

* (FOR USE WHEN PROPERTY VALVE CANNOT BE INSTALLED INSIDE PROPERTY - WITH APPROVAL OF MANAGER)

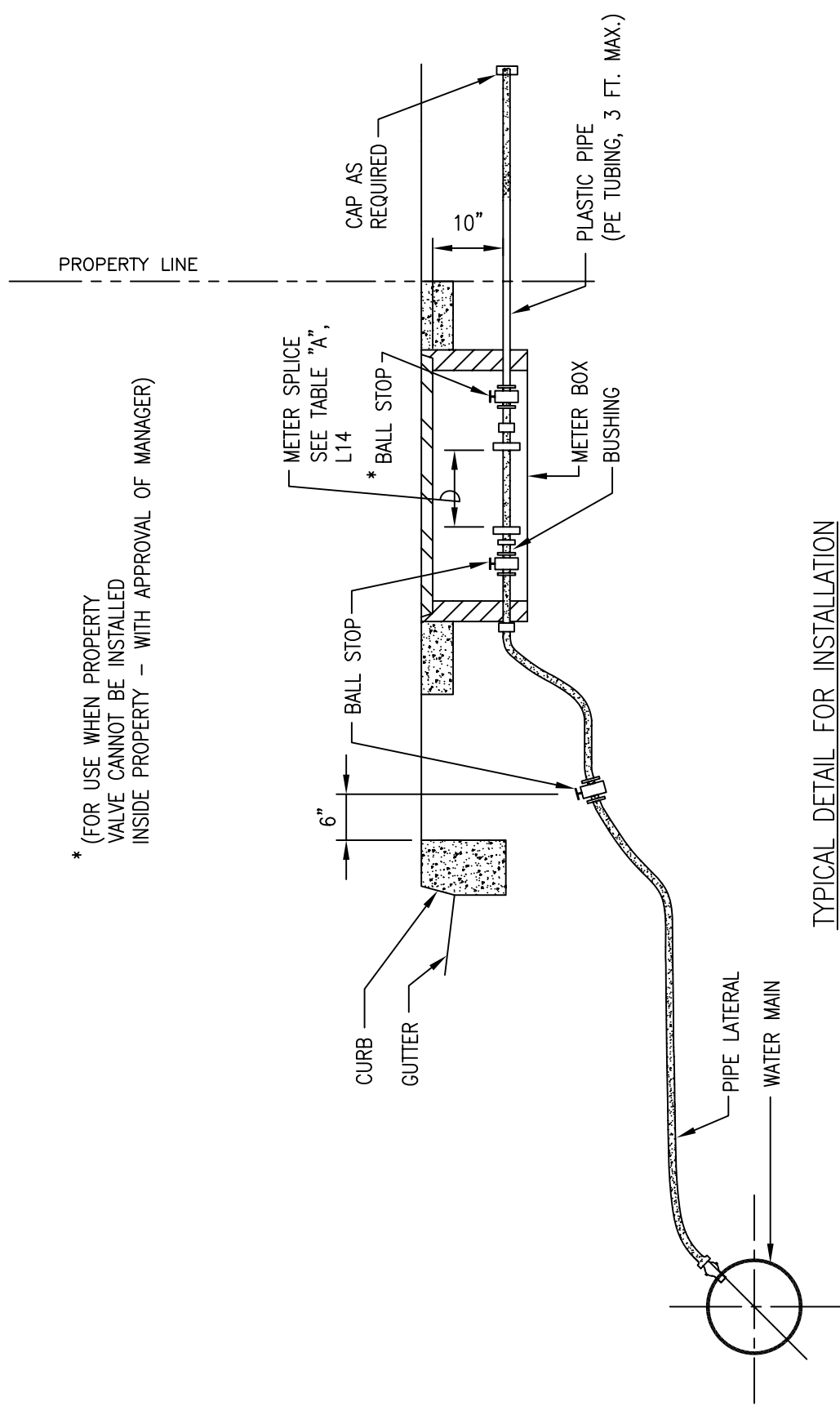

TYPICAL DETAIL FOR INSTALLATION OF BALL STOP AFTER METER

OAHU	<p>TYPICAL DETAIL FOR INSTALLATION OF BALL STOP AFTER METER</p> <p>SCALE: NTS</p>	STANDARD DETAILS	<table border="1"> <tr> <td data-bbox="1372 1858 1421 1900"></td> <td data-bbox="1421 1858 1518 1900">2008</td> </tr> <tr> <td data-bbox="1372 1900 1421 2005"></td> <td data-bbox="1421 1900 1518 2005">REVISION</td> </tr> </table> <p>L20</p>		2008		REVISION
	2008						
	REVISION						

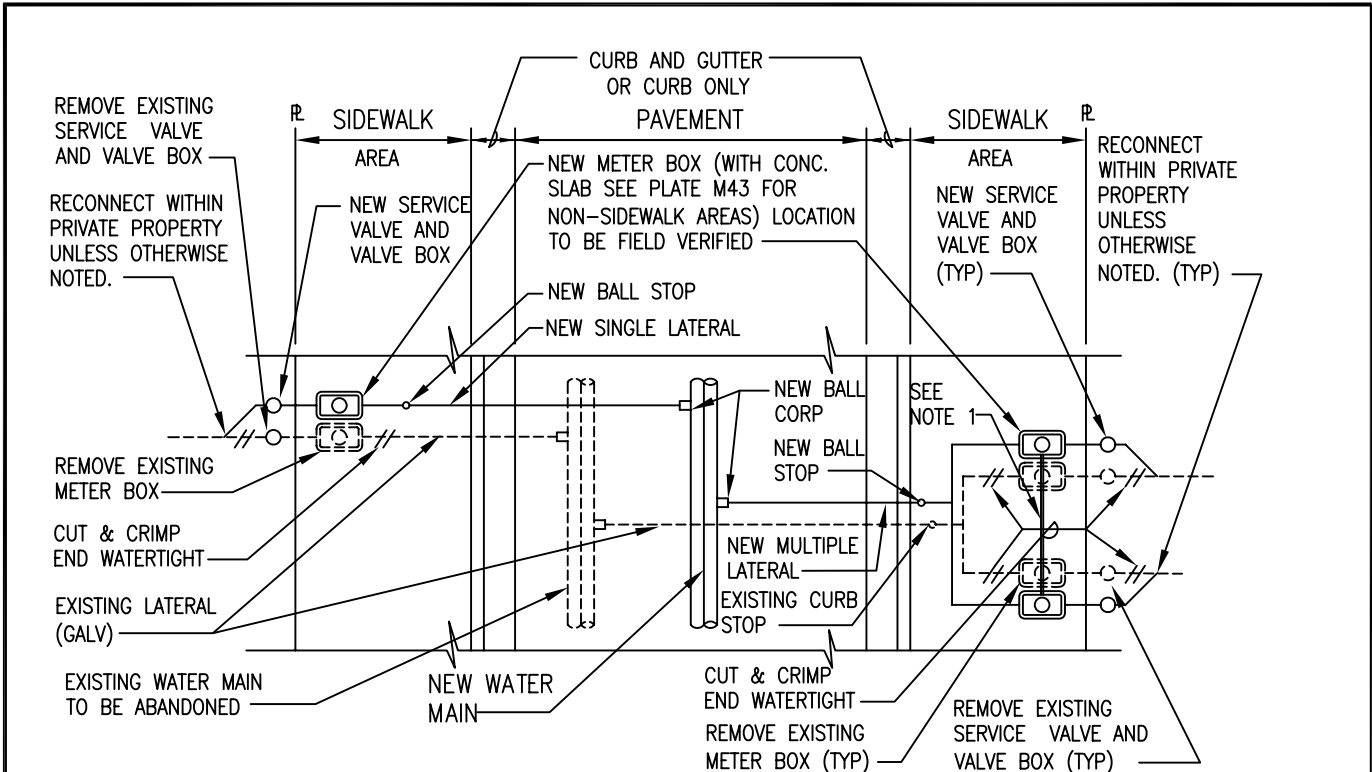

PLAN

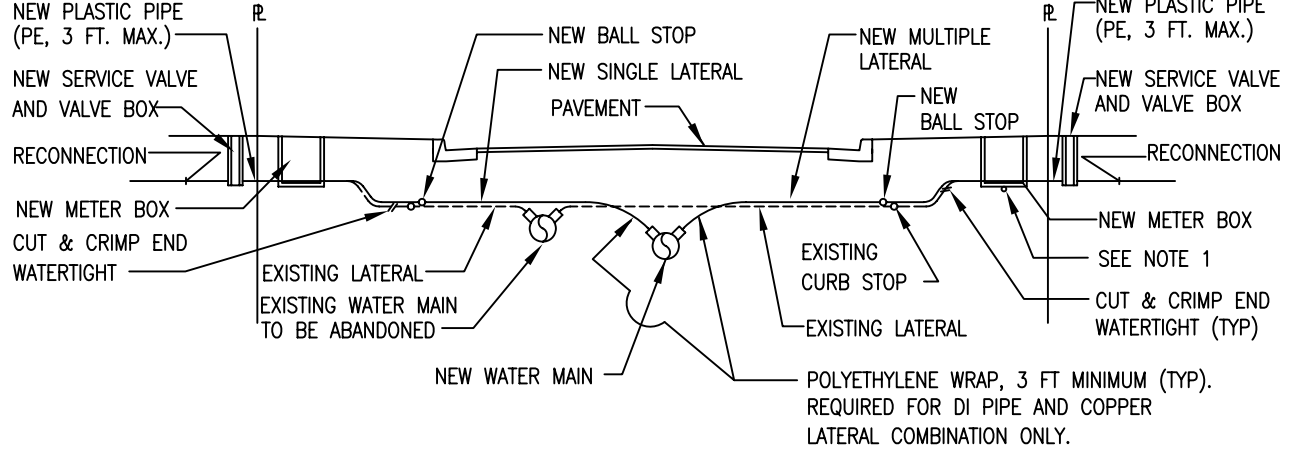

PROFILE

NOTE:

1. CONTRACTOR SHALL INSTALL A 3/4" PVC SCHEDULE 80 CONDUIT WITH STRING WHENEVER THE DISTANCE BETWEEN METER BOXES (2 TO 12 MULTIPLE METER BOXES) IS 4'-0" OR LESS (EDGE TO EDGE). CONDUIT SHALL EXTEND 2" WITHIN METER BOX, KEEP BOTH ENDS EXPOSED, PLUG OR TAPE TO PREVENT SOIL INTRUSION, AS REQUIRED. SAW CUT TRENCH AS REQUIRED AND REPAIR TO MATCH EXISTING CONDITIONS. FOR CONCRETE SLAB, REPAIR TRENCH WITH EPOXY MORTAR, LEVEL AND FINISH TO MATCH EXISTING.

2008
REVISION

OAHU	NEW LATERAL INSTALLATION SCHEMATIC DETAIL SCALE: NTS	STANDARD DETAILS	L21
------	---	---------------------	------------

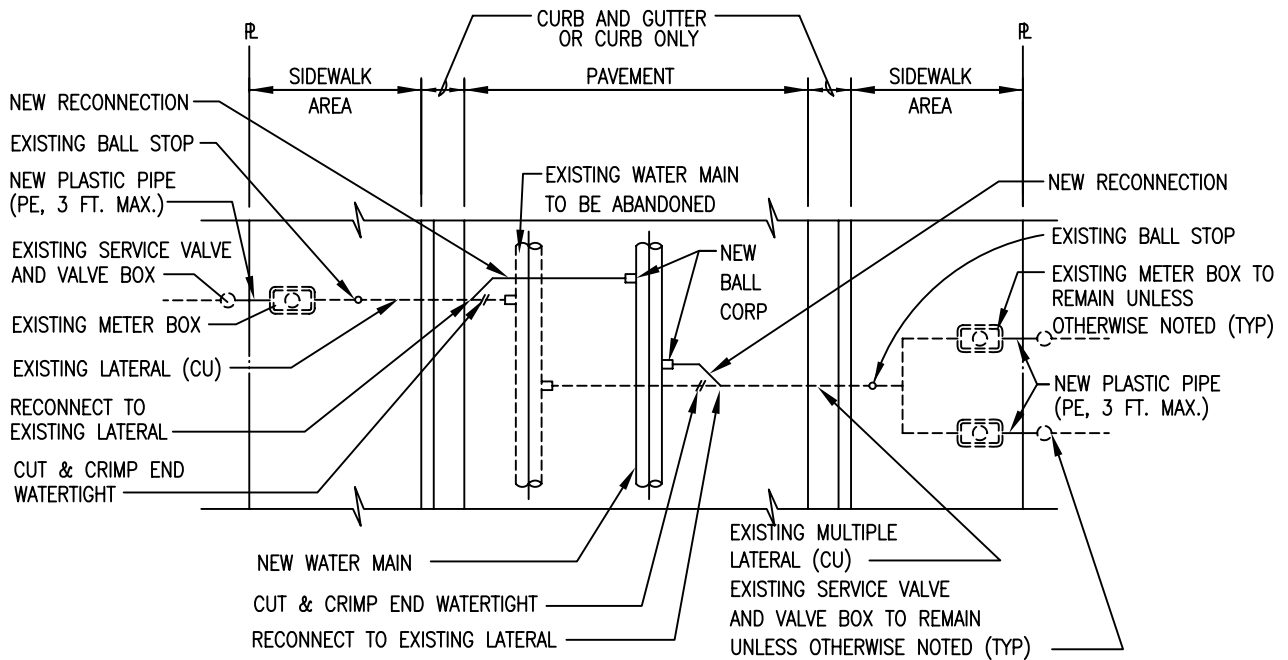

PLAN

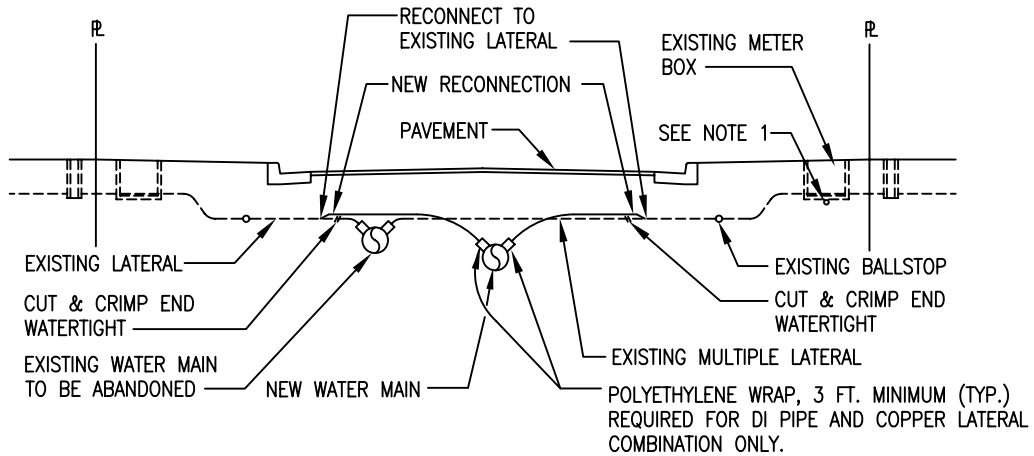

PROFILE

NOTE:

1. CONTRACTOR SHALL INSTALL A 3/4" PVC SCHEDULE 80 CONDUIT WITH STRING WHENEVER THE DISTANCE BETWEEN METER BOXES (2 TO 12 MULTIPLE METER BOXES) IS 4'-0" OR LESS (EDGE TO EDGE). CONDUIT SHALL EXTEND 2" WITHIN METER BOX, KEEP BOTH ENDS EXPOSED, PLUG OR TAPE TO PREVENT SOIL INTRUSION, AS REQUIRED. SAW CUT TRENCH AS REQUIRED AND REPAIR TO MATCH EXISTING CONDITIONS. FOR CONCRETE SLAB, REPAIR TRENCH WITH EPOXY MORTAR, LEVEL AND FINISH TO MATCH EXISTING.

2008
REVISION

OAHU	LATERAL RECONNECTION SCHEMATIC DETAIL SCALE: NTS	STANDARD DETAILS	L22
------	---	---------------------	-----

BOARD OF WATER SUPPLY

CITY AND COUNTY OF HONOLULU
630 SOUTH BERETANIA STREET
HONOLULU, HI 96843



December 19, 2008

MUFI HANNEMANN, Mayor

RANDALL Y. S. CHUNG, Chairman
SAMUEL T. HATA
ALLY J. PARK
ROBERT K. CUNDIFF
MARC C. TILKER

CRAIG I. NISHIMURA, Ex-Officio
BRENNON T. MORIOKA, Ex-Officio

CLIFFORD P. LUM
Manager and Chief Engineer

DEAN A. NAKANO
Deputy Manager and Chief Engineer

Mr. Bob Lake, President
CBC, Inc.
P. O. Box 669
Kailua, Hawaii 96734-0669

Dear Mr. Lake:

Subject: Your Letter Dated May 19, 2008 Regarding the State of Hawaii 2002
Water System Standards Consideration for Permanent Inclusion

We approve the American R/D Bevel Geared Gate Valve, Model 52, sizes 16-Inch to 42-Inch for inclusion into our Water System Standards.

If you have any questions, please contact Michael Domion at 748-5740.

Very truly yours

for DEAN A. NAKANO
Deputy Manager

cc: Kauai, Maui, Hawaii Water Departments

BOARD OF WATER SUPPLY

CITY AND COUNTY OF HONOLULU
630 SOUTH BERETANIA STREET
HONOLULU, HI 96843



June 26, 2015

KIRK CALDWELL, MAYOR

DUANE R. MIYASHIRO, Chair
ADAM C. WONG, Vice Chair
THERESIA C. McMURDO
DAVID C. HULIHEE
KAPUA SPROAT

ROSS S. SASAMURA, Ex-Officio
FORD N. FUCHIGAMI, Ex-Officio

ERNEST Y. W. LAU, P.E.
Manager and Chief Engineer

ELLEN E. KITAMURA, P.E.
Deputy Manager and Chief Engineer

Mr. Paul Boghossian
Armorcast Products Company
13230 Saticoy Street
North Hollywood, California 91605

Dear Mr. Boghossian:

Subject: Amendment to the Approval Letter Dated December 4, 2008, for
Polymer Concrete Type X and Type B Meter Box and Cover

Effective immediately for Oahu only, all Polymer Concrete Type X Meter Box Covers shall be furnished with a cast iron reader lid as shown on the enclosed Drawing No. A6001869TRCI.

If you have any questions, please contact Michael Domion, Support Branch Head, Capital Projects Division, at 748-5740.

Very truly yours,

ERNEST Y. W. LAU, P.E.
Manager and Chief Engineer

Enclosure

cc: Kauai, Maui, and Hawaii Department of Water Supply
D. Hiromoto, D. Ching, L. Fujikami, Support, Admin.
MD:st

APPROX. WT. = 25 LBS.

CAST IRON
READER LID

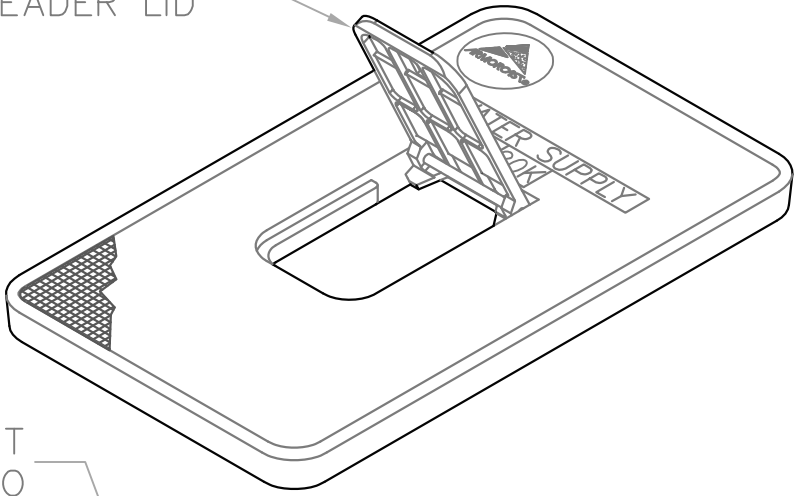

ARMORCAST
LOGO

R=1"

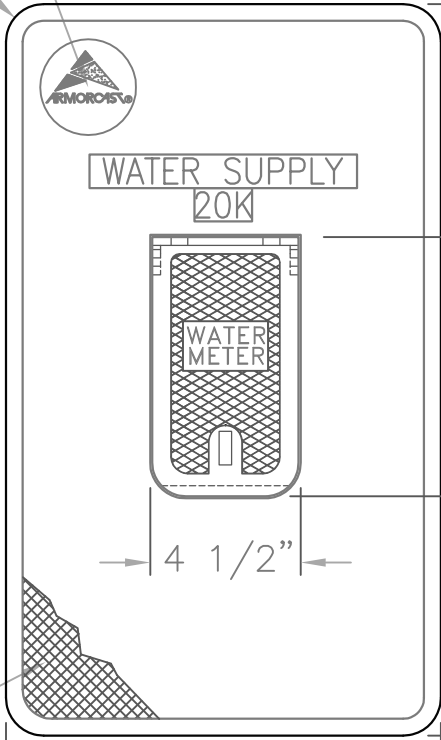

NON SKID
SURFACE



1/4"

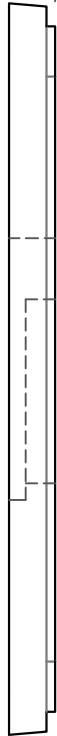

21 7/8"
7 3/4"

4 1/2"

1 3/8"

1 1/8"

TYPE X COVER W/ CAST IRON READ LID

FILE #
A6-1869TRCI-OAHU



13230 Satcoy Street,
North Hollywood, CA 91605
(818) 982-3600

ARMORCAST® PRODUCTS COMPANY

"THE INFORMATION IN THIS DRAWING IS CONFIDENTIAL. THE DRAWING IS NOT TO BE REPRODUCED OR ITS CONTENTS DIVULGED IN ANY WAY WHATSOEVER EXCEPT WITH THE PRIOR WRITTEN APPROVAL OF ARMORCAST PRODUCTS COMPANY. IT IS THE PROPERTY OF AND MUST BE RETURNED TO ARMORCAST PRODUCTS COMPANY, 13230 SATICOY STREET, NORTH HOLLYWOOD, CALIFORNIA 91605."

PART DESCRIPTION
13" X 21 7/8" X 1 1/8" POLYMER CONCRETE COVER

CUSTOMER
BOARD OF WATER SUPPLY - OAHU

DRAWN GL	DATE 12/06	SCALE NONE	MAX. LOAD 20K
APPROV. WS	DATE 12/06	MATERIAL POLYMER CONCRETE	DRAWING NUMBER A6001869TRCI

BOARD OF WATER SUPPLY

CITY AND COUNTY OF HONOLULU
630 SOUTH BERETANIA STREET
HONOLULU, HI 96843



December 4, 2008

MUFI HANNEMANN, Mayor

RANDALL Y. S. CHUNG, Chairman
SAMUEL T. HATA
ALLY J. PARK
ROBERT K. CUNDIFF
MARC C. TILKER

CRAIG J. NISHIMURA, Ex-Officio
BRENNON T. MORIOKA, Ex-Officio

CLIFFORD P. LUM
Manager and Chief Engineer

DEAN A. NAKANO
Deputy Manager and Chief Engineer

Mr. Paul H. Boghossian
Amorcast Products Company
13230 Saticoy Street
North Hollywood, California 91605

Dear Mr. Boghossian:

Subject: Your Letter Dated July July 28, 2008 Regarding Product Approval Request for
Polymer Concrete Type X and B Meter Box and Cover

We approve the following materials for inclusion in our Water System Standards:

	<u>Model No.</u>	<u>Description</u>
1.	A6000477	12"x21"x12" Polymer Concrete Type X Meter Box
2.	A6001869T	12"x21" Polymer Concrete Type X Cover
3.	A6000494	9"x14"x12" Polymer Concrete Type B Meter Box
4.	A6000482T	9"x14" Polymer Concrete Type B Cover

If you have any questions, please contact Michael Domion at (808)748-5740.

Very truly yours,

DEAN A. NAKANO
Deputy Manager

cc: Kauai, Maui, Hawaii Water Departments

M. Fuke, K. Shida
D. Ching, L. Fujikami, M. Domion, R. Remigio

08-0810

080810



ARMORCAST PRODUCTS COMPANY

13230 Saticoy Street
North Hollywood, California 91605
Telephone: (818) 982-3600
Fax #: (818) 982-7742

RECEIVED
BOARD OF WATER SUPPLY

2008 JUL 30 A 11: 16

Mar
Rep
Eng

Clifford P. Lum
Manager and Chief Engineer
Honolulu Board of Water Supply
630 S. Beretania Street
Honolulu, HI 96843

July 28, 2008

Re: Request for Product Approval

Mr. Lum,

Please accept this correspondence as a formal request for approval of Armorcast Products Company polymer concrete meter boxes and covers for use as equal to your current specification. We have supplied both standard sizes for field evaluation in January of 2007. Below are the product number references for your convenience:

A6000477	12"x21"x12" Polymer Concrete Type X Meter Box
A6001869T	12"x21" Polymer Concrete Type X Cover
A6000494	9"x14"x12" Polymer Concrete Type B Meter Box
A6000482T	9"x14" Polymer Concrete Type B Cover

A armorcast enclosures have been installed over the past 20 years in many of Hawaii's utility distribution systems such as Verizon (Hawaiian Telephone) and Hawaiian Electric. We would truly appreciate the opportunity to service the Honolulu Board of Water Supply as well.

Sincerely,



Paul H. Boghossian
Armorcast Products Company

CC: Lan Yoneda, P.E./Honolulu Board of Water Supply
Wally Sunnaa, P.E./Armorcast Products Company

APPROX. WT. = 25 LBS.

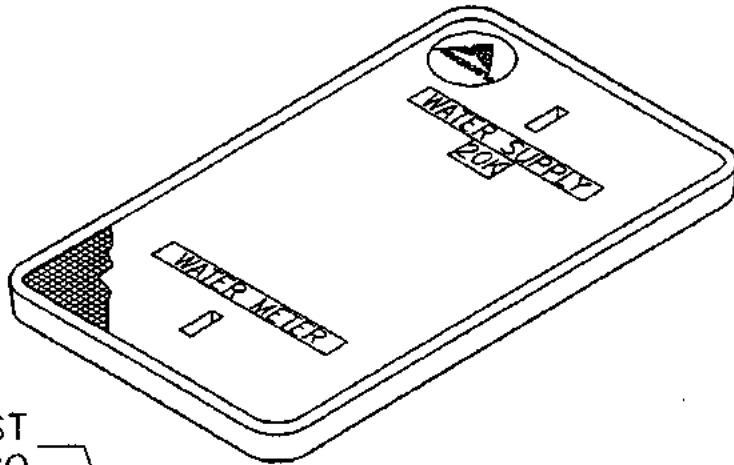

ARMORCAST
LOGO

R=1"

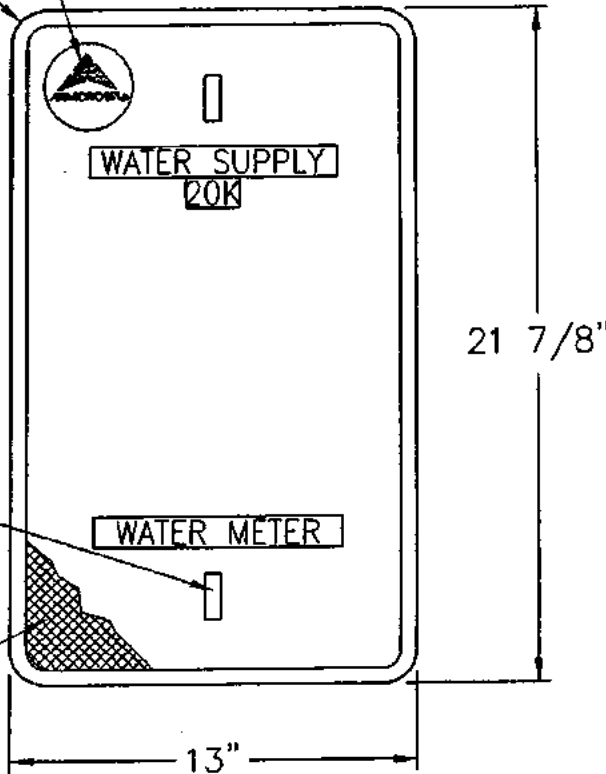

1/2" X 1 1/2"
PICK HOLE (2X)

NON SKID
SURFACE

1/4"

1 1/8"

1 3/8"

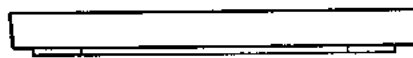

FILE #
AG-1869T-OAHU



13230 Saticoy Street,
North Hollywood, CA 91605
(818) 982-3800

ARMORCAST PRODUCTS COMPANY

PART DESCRIPTION

13" X 21 7/8" X 1 1/8" POLYMER CONCRETE COVER

CUSTOMER

BOARD OF WATER SUPPLY - OAHU

DRAWN
GL

DATE
12/06

SCALE
NONE

MAX. LOAD
20K

APPROV.
WS

DATE
12/06

MATERIAL
POLYMER CONCRETE

DRAWING NUMBER

A6001869T

THE INFORMATION IN THIS DRAWING IS CONFIDENTIAL. THE DRAWING IS NOT TO BE REPRODUCED OR ITS CONTENTS DISCLOSED IN ANY WAY WHATSOEVER EXCEPT WITH THE PRIOR WRITTEN APPROVAL OF ARMORCAST PRODUCTS COMPANY. IT IS THE PROPERTY OF AND MUST BE RETURNED TO ARMORCAST PRODUCTS COMPANY, 13230 SATICOY STREET, NORTH HOLLYWOOD, CALIFORNIA 91605.

APPROX. WT. = 25 LBS.

POLYMER CONCRETE
READER LID

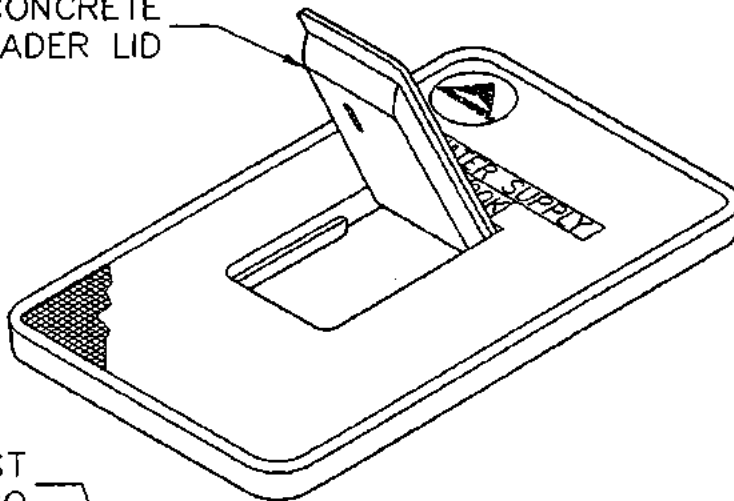

ARMORCAST
LOGO

R=1"

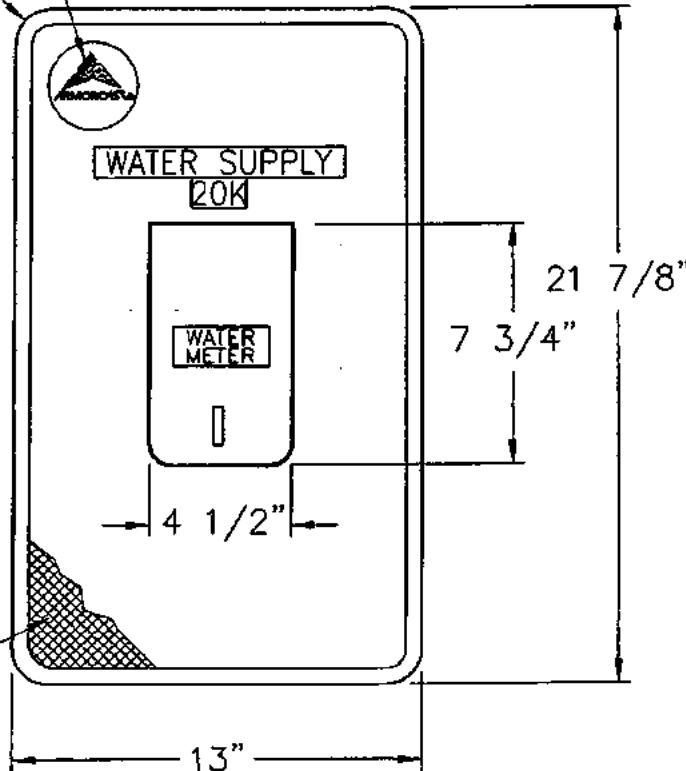

NON SKID
SURFACE

1/4"

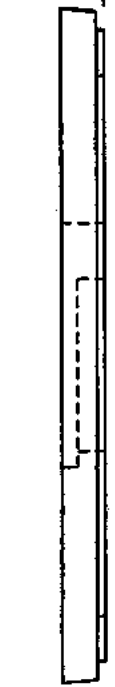

1 1/8"

1 3/8"

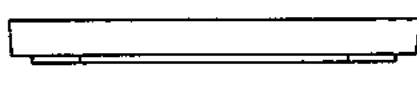

REV. 1
AS-1869TR-OAHU



13230 Sollicoy Street,
North Hollywood, CA 91605
(818) 982-3600
ARMORCAST PRODUCTS COMPANY

PART DESCRIPTION
13" X 21 7/8" X 1 1/8" POLYMER CONCRETE COVER

CUSTOMER
BOARD OF WATER SUPPLY - OAHU

"THE INFORMATION IN THIS DRAWING IS CONFIDENTIAL. THE DRAWING IS NOT TO BE REPRODUCED OR ITS CONTENTS DIVULGED IN ANY WAY WHATSOEVER EXCEPT WITH THE PRIOR WRITTEN APPROVAL OF ARMORCAST PRODUCTS COMPANY. IT IS THE PROPERTY OF AND MUST BE RETURNED TO ARMORCAST PRODUCTS COMPANY, 13230 SATICOY STREET, NORTH HOLLYWOOD, CALIFORNIA 91605."

DRAWN GL	DATE 12/06	SCALE NONE	MAX. LOAD 20K
APPROV. WS	DATE 12/06	MATERIAL POLYMER CONCRETE	DRAWING NUMBER A6001869TR

APPROX. WT. 10 LBS.

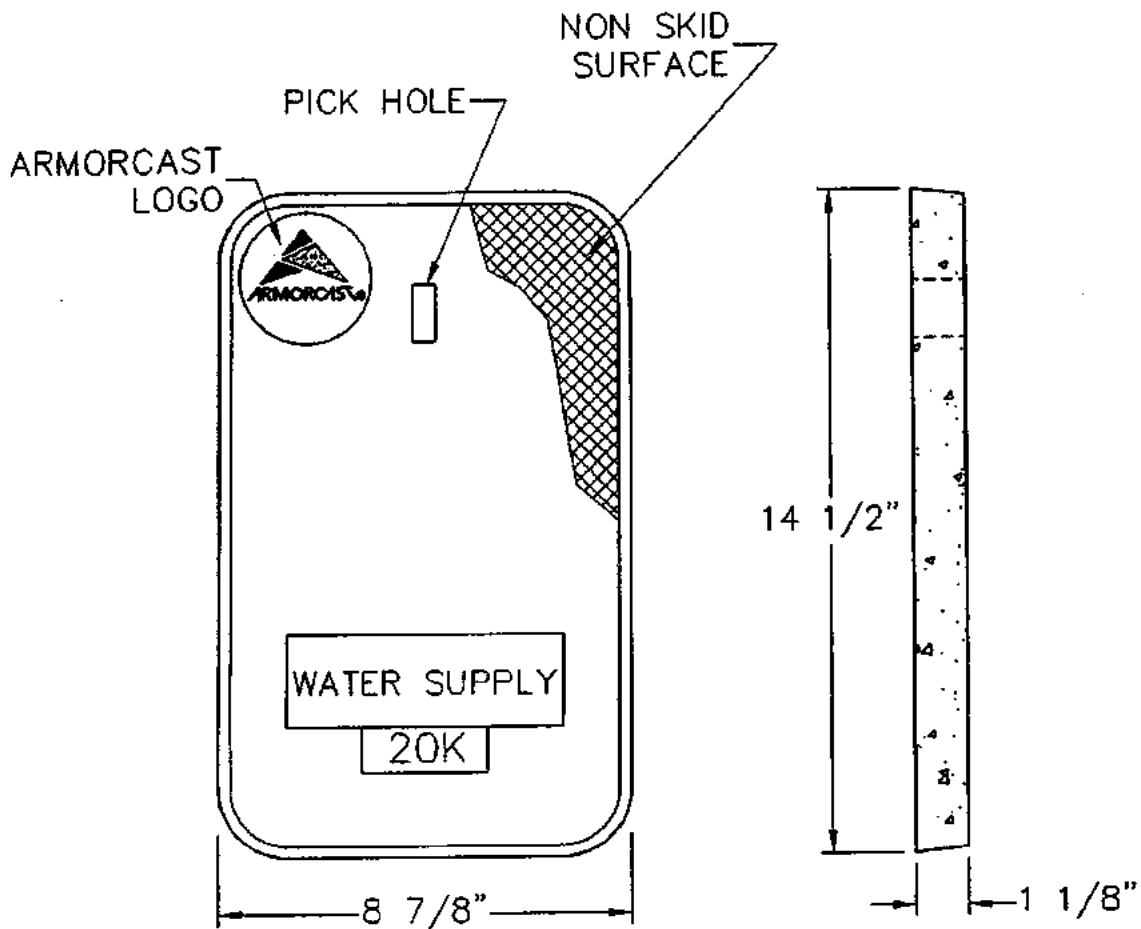
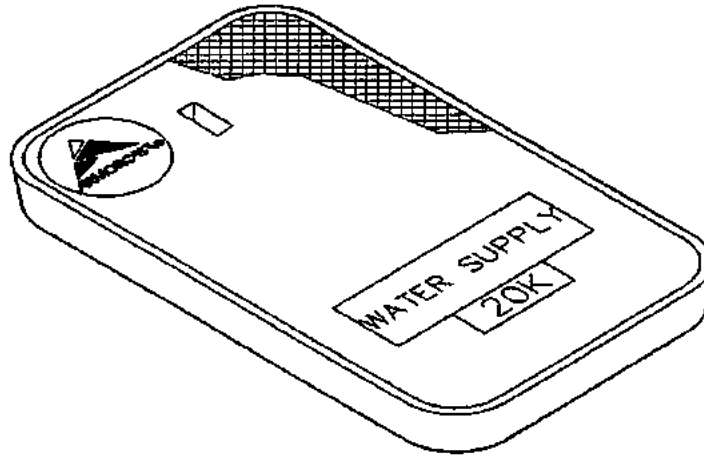

POLYMER CONCRETE COVER

FILE #
AS-0482T-OAHU



13230 Saticoy Street,
North Hollywood, CA 91605
(818) 982-3600

ARMORCAST PRODUCTS COMPANY

THE INFORMATION IN THIS DRAWING IS CONFIDENTIAL. THE DRAWING IS NOT TO BE REPRODUCED OR ITS CONTENTS DISCLOSED IN ANY WAY WHATSOEVER EXCEPT WITH THE PRIOR WRITTEN APPROVAL OF ARMORCAST PRODUCTS COMPANY. IT IS THE PROPERTY OF AND MUST BE RETURNED TO ARMORCAST PRODUCTS COMPANY, 13230 SATICOY STREET, NORTH HOLLYWOOD, CALIFORNIA 91605.

PART DESCRIPTION

9" X 14" X 1 1/8" POLYMER CONCRETE COVER

CUSTOMER

BOARD OF WATER SUPPLY - OAHU

DRAWN

DA

DATE

12/06

SCALE

NONE

MAX. LOAD

20K

APPROV.

WS

DATE

12/06

MATERIAL

POLYMER CONCRETE

DRAWING NUMBER

A6000482T

APPROX. BOX WT. = 40 LBS.

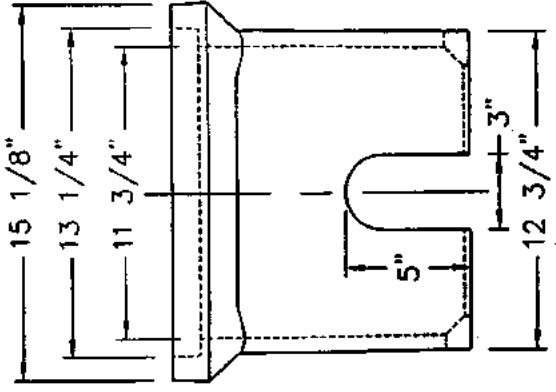
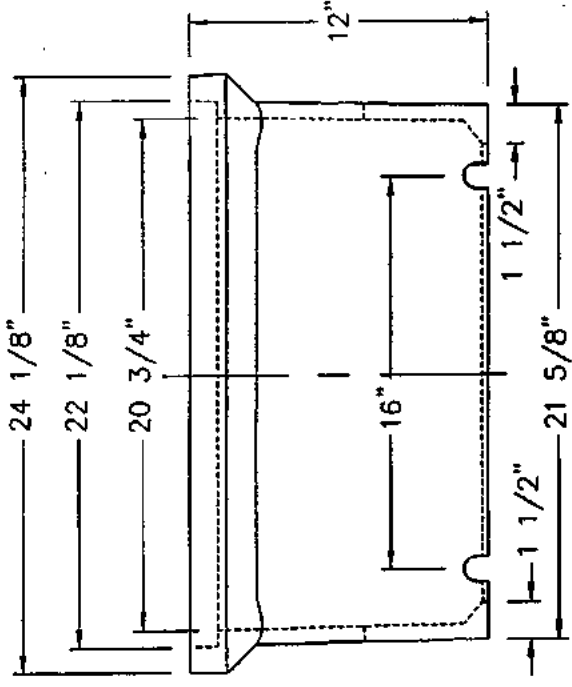
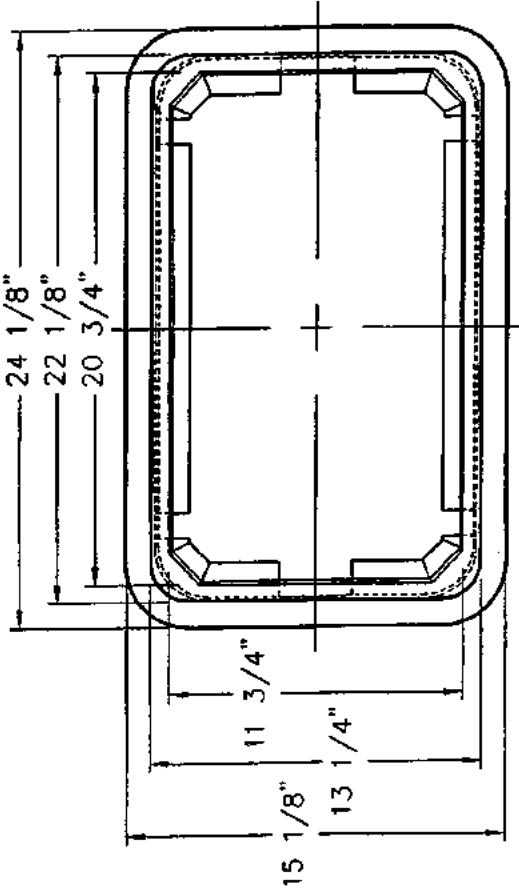
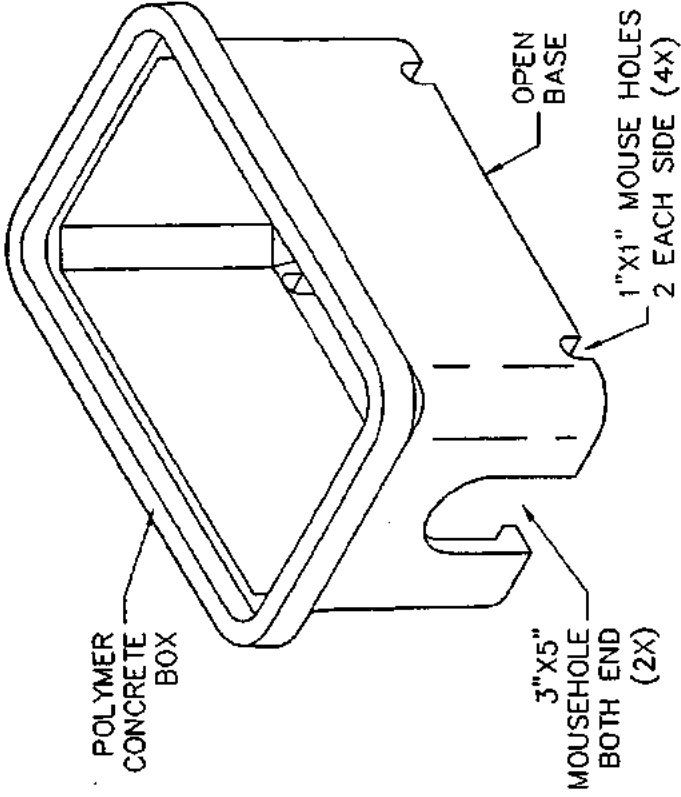

END VIEW FOR 1 1/2" & 2" METER

SIDE VIEW

		12320 Highway 27 West, Hayward, California 94545 (415) 883-3800	
POLYMER PRODUCTS COMPANY		TYPE X WATER METER BOX - 12" X 21" X 12"	
BOARD OF WATER SUPPLY - OAHU	DATE	ORDER NO.	QUANTITY
VS	12/06	12/06	12/06
POLYMER CONCRETE	POLYMER CONCRETE	POLYMER CONCRETE	POLYMER CONCRETE
A6000477	OAHU	A6000477	OAHU

A6-0477X12-OAHU

APROX. WT. 26 LBS

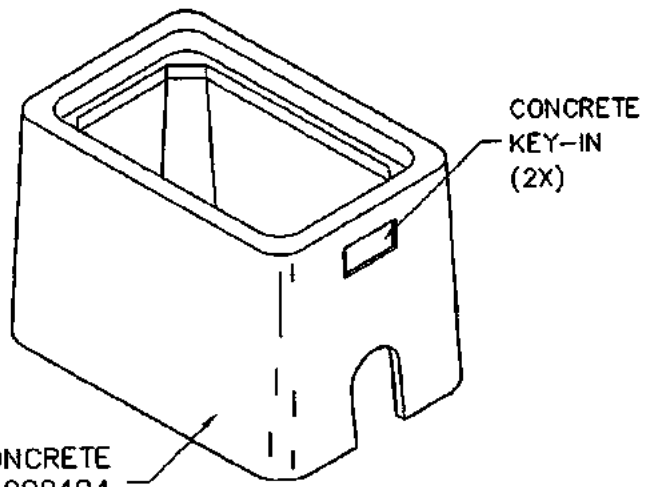
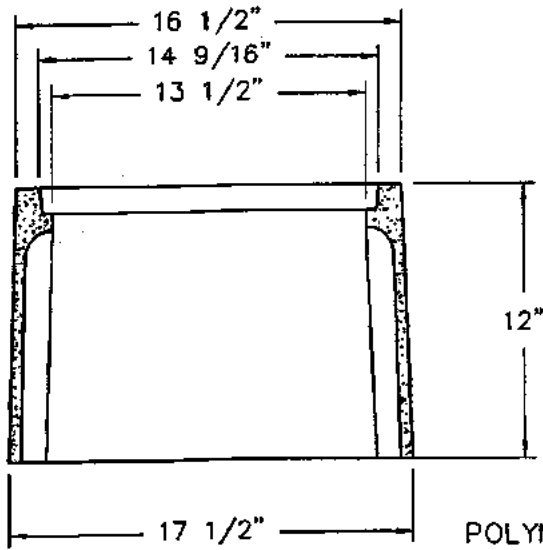

POLYMER CONCRETE BOX A6000494

SECTION A-A

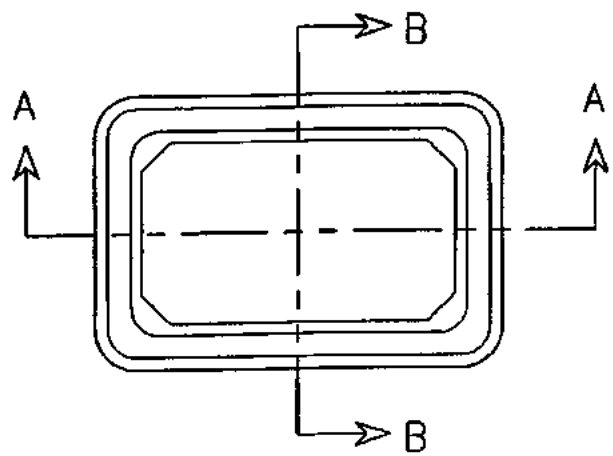

TOP VIEW

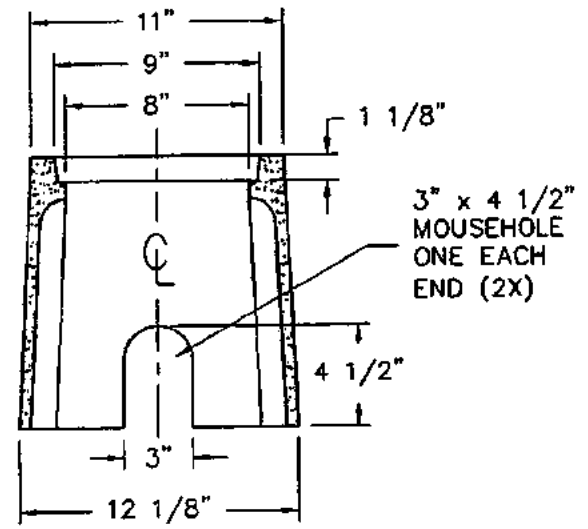

SECTION B-B

FILE # AS-0494-0411	 13230 Saticoy Street, North Hollywood, CA 91605 (818) 982-3600 ARMORCAST PRODUCTS COMPANY	PART DESCRIPTION		
		9" X 14" X 12" POLYMER CONCRETE BOX		
		CUSTOMER		
		BOARD OF WATER SUPPLY - OAHU		
DRAWN	DATE	SCALE	MAX. LOAD	
QA	9/02	NONE		
APPROV.	DATE	MATERIAL	DRAWING NUMBER	
WS	9/02	POLYMER CONCRETE	A6000494	

THE INFORMATION IN THIS DRAWING IS CONFIDENTIAL. THE DRAWING IS NOT TO BE REPRODUCED OR ITS CONTENTS DIVULGED IN ANY WAY WHATSOEVER EXCEPT WITH THE PRIOR WRITTEN APPROVAL OF ARMORCAST PRODUCTS COMPANY. IT IS THE PROPERTY OF AND MUST BE RETURNED TO ARMORCAST PRODUCTS COMPANY, 13230 SATICOY STREET, NORTH HOLLYWOOD, CALIFORNIA 91605.

BOARD OF WATER SUPPLY

CITY AND COUNTY OF HONOLULU
630 SOUTH BERETANIA STREET
HONOLULU, HI 96843



October 21, 2008

MUFI HANNEMANN, Mayor

RANDALL Y. S. CHUNG, Chairman
SAMUEL T. HATA
ALLY J. PARK
ROBERT K. CUNDIFF
MARC C. TILKER

CRAIG I. NISHIMURA, Ex-Officio
BRENNON T. MORIOKA, Ex-Officio

CLIFFORD P. LUM
Manager and Chief Engineer

DEAN A. NAKANO
Deputy Manager and Chief Engineer

TO: WHOM IT MAY CONCERN

FROM: 
CLIFFORD P. LUM, MANAGER AND CHIEF ENGINEER
BOARD OF WATER SUPPLY

SUBJECT: 2002 WATER SYSTEM STANDARDS AMENDMENT FOR DISTANCE
BETWEEN MAIN VALVES

The following amendments to the 2002 Water System Standards are effective immediately for **Oahu only**:

Division 100, Section 103 MAIN VALVES, Subsection 103.01 LOCATION, TYPE, WORKING PRESSURE :

1. Delete Table 100-9 and replace with the following:

Table 100-9 - MAXIMUM DISTANCE BETWEEN MAIN VALVES (FEET)		
Residential, Agricultural	Transmission Mains	All Others Districts
750	2,000 ^{a,d}	500 ^{b,c}

- a - *For Maui only: For mains 16-inch diameter or larger or as determined by the Manager, otherwise 1,000 feet.*
- b - *Or as determined by the Manager.*
- c - *For mains that provide a one-way feed to subdivisions with more than 100 lots as determined by the Manager.*
- d - *For Oahu only: For mains 16-inch diameter or larger, maximum distance between main valves shall be 1,000 feet.*

2. Delete Table 100-10 and replace with the following:

Table 100-10 - TYPES AND SIZE OF MAIN VALVES			
Island	Gate Valves	Bevel Geared	Butterfly
Maui	5 ^a	NA	6
Kauai, Oahu	1	2 ^b	2
Hawaii	3	NA	4

- 1 - 12-inch and smaller
- 2 - 16-inch and larger
- 3 - 8-inch and smaller
- 4 - Larger than 8-inch
- 5 - 16-inch and smaller (subject to pressure)
- 6 - 18-inch and larger
- NA - Not Allowed

- a - For 16-inch mains with working pressure of 100 psi or greater, use butterfly valves.
- b - *For Oahu Only: Install bevel-gated gate valves with bypass at key locations including, but not limited to, facilities, intersections (cluster valve locations) and every 2,000 feet spacing for long continuous transmission mains. The Manager may specify the type of valve to be used for transmission mains.*

If you have any questions, please contact Michael Domion at 748-5740.

cc: Kauai, Maui, Hawaii Water Departments

BOARD OF WATER SUPPLY

CITY AND COUNTY OF HONOLULU
630 SOUTH BERETANIA STREET
HONOLULU, HI 96843



March 18, 2008

MUFI HANNEMANN, Mayor

RANDALL Y. S. CHUNG, Chairman
SAMUEL T. HATA
ALLY J. PARK
ROBERT K. CUNDIFF
MARC C. TILKER

CRAIG I. NISHIMURA, Ex-Officio
BRENNON T. MORIOKA, Ex-Officio

CLIFFORD P. LUM
Manager and Chief Engineer

DEAN A. NAKANO
Deputy Manager and Chief Engineer

TO: WHOM IT MAY CONCERN

FROM: 
CLIFFORD P. LUM, MANAGER AND CHIEF ENGINEER
BOARD OF WATER SUPPLY

SUBJECT: 2002 WATER SYSTEM STANDARDS AMENDMENTS FOR NUTS AND BOLTS

The following amendments to the 2002 Water System Standards are effective immediately for Oahu only:

**Division 200, Section 202 DUCTILE IRON PIPE, FITTINGS AND APPURTENANCES,
Subsection 202.04 FLANGED JOINT:**

Delete the following (4th paragraph, page 202-5):

The bolts used for all flanged joints shall protrude beyond the nuts a minimum of 1/8-inch, but shall not exceed 1/2-inch. All stainless steel bolt and nut threads shall be pre-coated with anti-seizing graphite compound before installation. Should the bolts protrude more than 1/2-inch, the bolt ends shall be machine cut before installation. Bolts shall be with cut threads and American Standard heavy hexagon heads. Nuts shall be compatible with the bolts in strength and material characteristics. Nuts shall be hexagon. Bolts and nuts for flanges shall conform to one of the following:

1. Silicon bronze bolts and nuts shall conform to ASTM F467 and F468.
2. Stainless Steel bolts and nuts shall conform to ASTM F593 and F594, type 316.

Replace with the following:

The bolts used for all flanged joints shall protrude beyond the nuts a minimum of 1/8-inch, but shall not exceed 1/2-inch. All stainless steel bolt and nut threads shall be pre-coated with anti-seizing graphite compound before installation. Should the bolts protrude more than 1/2-inch, the bolt ends shall be machine cut before installation. Bolts shall be with cut threads and American Standard heavy hexagon heads. Nuts shall be compatible with the bolts in strength and material characteristics. Nuts shall be hexagon. Bolts and nuts for flanges shall conform to one of the following:

1. Silicon bronze bolts and nuts shall conform to ASTM F467 and F468.
2. For installations in vaults: Bolts and nuts shall be stainless steel, type 304, and shall conform to ASTM F593 and F594.
3. For buried installations: Bolts and nuts shall be corrosion resistant coated Cor-Ten®.

**Division 200, Section 206 HYDRANTS AND APPURTENANCES,
Subsection 206.01 GENERAL:**

Delete the following (6th paragraph, page 206-1):

Each hydrant body shall be furnished with a set of break-off bolts, nuts, and full face gasket. Bolts shall be stainless steel 5/8" x 3" machine bolts with hexagon heads American Standard heavy. Bolts shall be break-off type drilled 11/32" x 1-3/8". Nuts shall be stainless steel American Standard heavy cold punched, hexagon nuts. Gaskets shall be 1/8-inch cloth inserted rubber. Hydrant flange shall have six (6) 3/4-inch bolt holes on 9.375-inch diameter.

Replace with the following:

Each hydrant body shall be furnished with a set of break-off bolts, nuts, and full face gasket. Bolts shall be hot-dipped galvanized 5/8"x3" machine bolts with hexagon heads American Standard heavy. Bolts shall be break-off type drilled 11/32"x1-3/8". Nuts shall be hot-dipped galvanized American Standard heavy cold-punched, hexagon nuts. Gaskets shall be 1/8-inch cloth inserted rubber. Hydrant flange shall have six (6) 3/4-inch bolt holes on 9.375-inch diameter.

If you have any questions, please contact Jason Takaki at 748-5740.

cc: Kauai, Maui, Hawaii Water Departments
M. Fuke, E. Kawata, K. Shida
J. Takaki, D. Ching, R. Remigio, Design Section

MD:st

BOARD OF WATER SUPPLY

CITY AND COUNTY OF HONOLULU
630 SOUTH BERETANIA STREET
HONOLULU, HI 96843



October 31, 2007

MUFI HANNEMANN, Mayor

RANDALL Y. S. CHUNG, Chairman
SAMUEL T. HATA
ALLY J. PARK
ROBERT K. CUNDIFF
MARC C. TILKER

LAVERNE T. HIGA, Ex-Officio
BARRY FUKUNAGA, Ex-Officio

CLIFFORD P. LUM
Manager and Chief Engineer

DEAN A. NAKANO
Deputy Manager and Chief Engineer

Mr. Christopher King
Western Division Manager
Sigma Corporation
316 So. Bon View Avenue
Ontario, California 91761

Dear Mr. King:

Subject: Your Letter Dated January 9, 2007 Regarding Approval of
SIGMA AWWA C110 Fittings

We approve the SIGMA Full Body Mechanical Joint Fittings and the Flanged Fittings for inclusion in the Water System Standards. The mechanical and flanged joint fittings meet the requirements of the AWWA C110 Standard.

If you have any questions, please contact Jason Takaki at (808)748-5740.

Very truly yours,

HOWARD H. TANAKA, Head
Capital Projects Division – Engineering Branch

cc: County Departments of Water
Jon Franzmeier (HISCO, Inc.)

GS:em

cc: Design Sect., Construction, Admin., Field Op., Plant Op., Supp. Sect.

BOARD OF WATER SUPPLY

CITY AND COUNTY OF HONOLULU
630 SOUTH BERETANIA STREET
HONOLULU, HI 96843



May 4, 2007

Supp

MUFI HANNEMANN, Mayor

RANDALL Y. S. CHUNG, Chairman
HERBERT S. K. KAOPUA, SR.
SAMUEL T. HATA
ALLY J. PARK
ROBERT K. CUNDIFF

LAVERNE T. HIGA, Ex-Officio
BARRY FUKUNAGA, Ex-Officio

CLIFFORD P. LUM
Manager and Chief Engineer

DEAN A. NAKANO
Deputy Manager and Chief Engineer

Mr. Michael Berry
Western Division Manager
Star Pipe Products
263 Livorna Heights Road
Alamo, California 94507

Dear Mr. Berry:

Subject: Letter Dated March 23, 2005 Requesting Inclusion of the Star Pipe Products C110 FB MJ and Flanged Fittings in the Approved Materials List

We approve the Star Pipe Products C110 Full-body Mechanical and Flanged Joint Fittings for inclusion in the Water System Standards for Oahu only. The mechanical and flanged joint fittings meet the applicable requirements of the AWWA Standards as well as the testing and evaluation criteria being enforced during the probationary period.

This approval officially ends the two-year probationary period without reported incident. Henceforth, Star Pipe products, like any other products, shall be subject to normal material monitoring. If deficiencies reappear, appropriate action will be taken.

If you have any questions, please contact Jason Takaki at (808)748-5740.

Very truly yours,

HOWARD H. TANAKA, Head
Capital Projects Division – Engineering Branch

cc: Supp. Sect.

BOARD OF WATER SUPPLY

CITY AND COUNTY OF HONOLULU
630 SOUTH BERETANIA STREET
HONOLULU, HI 96843



August 25, 2006

MUFU HANNEMANN, Mayor

RANDALL Y. S. CHUNG, Chairman
HERBERT S. K. KAOPUA, SR.
SAMUEL T. HATA
ALLY J. PARK
ROBERT K. CUNDIFF

RODNEY K. HARAGA, Ex-Officio
LAVERNE T. HIGA, Ex-Officio

CLIFFORD P. LUM
Manager and Chief Engineer

TO: WHOM IT MAY CONCERN
FROM: 
CLIFFORD P. LUM, MANAGER AND CHIEF ENGINEER
BOARD OF WATER SUPPLY

SUBJECT: INSTALLATION OF ELECTRONIC MARKERS

Effective immediately, the Honolulu Board of Water Supply (BWS) requires the installation of electronic markers in conjunction with all installations of water mains within the municipal water system, including any mains that may be dedicated to the BWS in the future. Electronic markers shall be installed along all mains, 4-inch diameter and larger, including non-potable water mains and fire hydrant and meter laterals. Electronic markers shall be installed in lieu of copper toning wire, where specified by the Water System Standards. Installation of the markers will facilitate pinpointing the locations of water mains in the field.

Installations shall be in accordance with the latest special provision for Electronic Markers. A copy of the current specification is attached.

If you have any questions, please contact Jason Takaki at 748-5740.

Attachments

cc: Customer Care (R. Chun)
Field Operations
D. Ching
F. Fung
J. Takaki

JT:em

SECTION SP-17 ELECTRONIC MARKERS

17.1 DESCRIPTION

This item of work shall include the furnishing of all labor, materials, tools and equipment necessary for the installation and testing of electronic markers for “locating” purposes.

Electronic markers shall be installed over all new mains 4-inch and larger including non-potable water mains, concrete jackets, mains under concrete pavement, and fire hydrant and meter laterals.

For plastic pipe, electronic markers shall be installed in lieu of copper toning wire.

17.2 MATERIAL

Electronic markers shall be the “Omni Marker”, manufactured by Tempo, or approved equal.

Application	Color	Frequency	Model Number	UPC Number
Potable Water Main	Blue	145.7 kHz	Model 161	60766
Non-Potable Water Main	Purple	66.35 kHz	Model 168	11050

17.3 CONSTRUCTION REQUIREMENTS

1. Placement

Electronic markers shall be hand placed in the trench, centered over the pipe and covered with sufficient base course material to prevent shifting prior to backfilling of the trench. Installation shall be at a minimum depth of two (2) feet and a maximum depth of three (3) feet from finish grade.

2. Location

Installation of electronic markers shall be in accordance with the following:

a. One marker at all changes in horizontal alignment.

- (1) Tees with branches 4-inches and larger
- (2) Bends
- (3) Deflection couplings
- (4) Deflections at joints

b. One marker 10 feet prior to and one marker 10 feet after a change in horizontal alignment unless markers are required within the 10 feet distance.

- c. On straight runs, markers shall be placed at a maximum distance of 40 feet.
- d. One marker at the end of all mains.
- e. Markers at the beginning and end of all concrete jackets.
- f. Markers at the beginning and end of all sections of mains under concrete pavement.
- g. One marker at the connection of the new main to the existing main.
- h. Markers shall not be placed at crossings with electrical duct lines, gas lines or telephone duct lines. Install markers at a minimum clearance of 5 feet from these utility crossings.

3. Testing

Contractor shall test the electronic markers prior to installation to verify proper operation. BWS personnel shall verify the number and locations of placed electronic markers prior to final paving.

17.4 PAYMENT

Payment for ELECTRONIC MARKERS will be made at the Unit Price Bid based on the actual amount installed.

The Unit Price Bid for ELECTRONIC MARKERS shall be full compensation for all labor, materials, tools and equipment necessary for furnishing and installing ELECTRONIC MARKERS and all other incidentals required to complete the work.

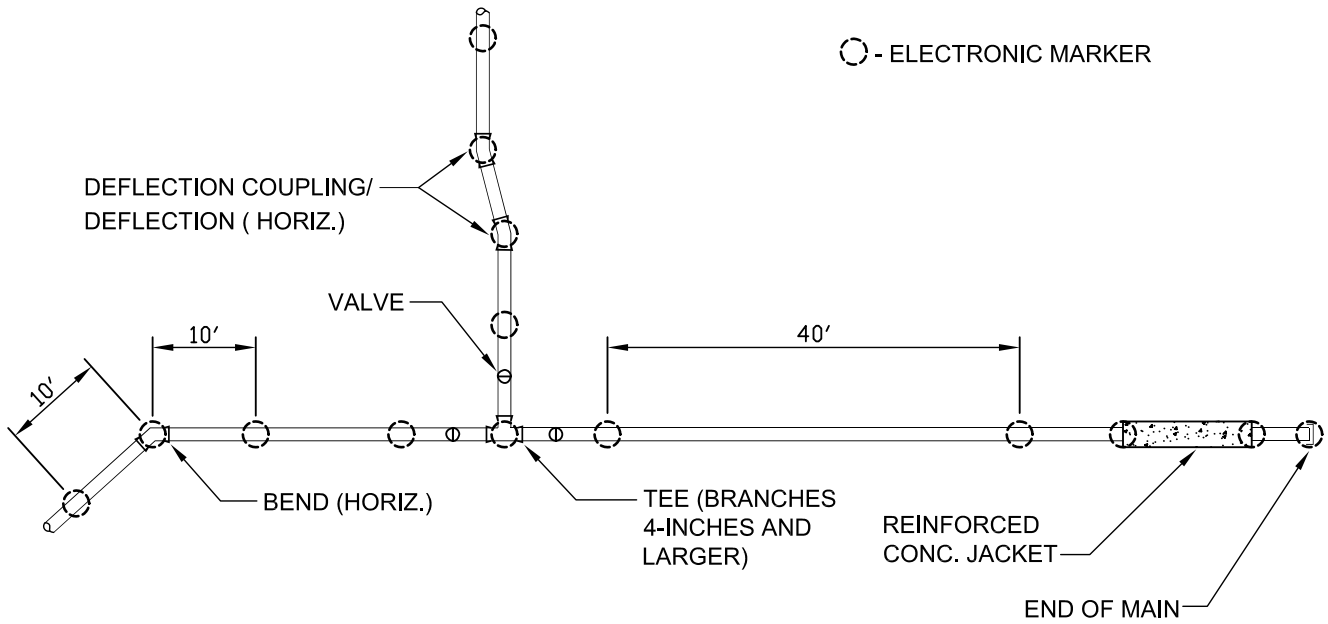

PLAN VIEW

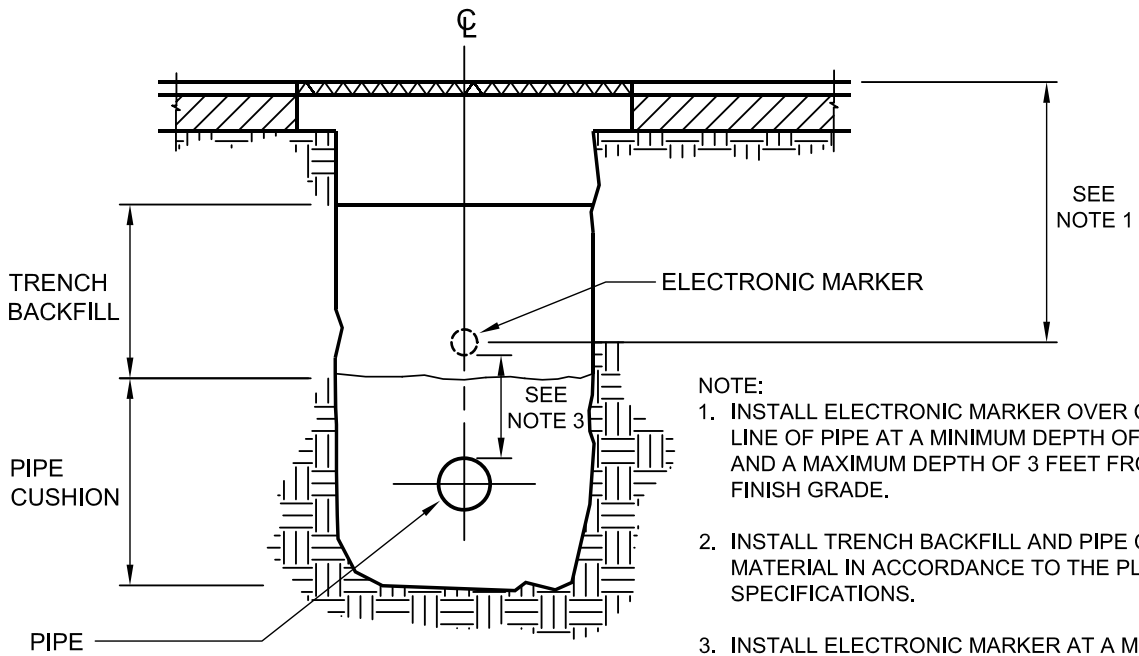

NOTE:

1. INSTALL ELECTRONIC MARKER OVER CENTER LINE OF PIPE AT A MINIMUM DEPTH OF 2 FEET AND A MAXIMUM DEPTH OF 3 FEET FROM FINISH GRADE.
2. INSTALL TRENCH BACKFILL AND PIPE CUSHION MATERIAL IN ACCORDANCE TO THE PLANS AND SPECIFICATIONS.
3. INSTALL ELECTRONIC MARKER AT A MINIMUM CLEARANCE OF 6-INCHES ABOVE THE PIPE OR CONCRETE JACKET.

SECTION VIEW

TYPICAL ELECTRONIC MARKER INSTALLATION

N.T.S.

DC

BOARD OF WATER SUPPLY

CITY AND COUNTY OF HONOLULU
630 SOUTH BERETANIA STREET
HONOLULU, HI 96843



January 27, 2004

JEREMY HARRIS, Mayor

EDDIE FLORES, JR., Chairman
CHARLES A. STED, Vice-Chairman
JAN M.L.Y. AMII
HERBERT S.K. KAOPUA, SR.
DAROLYN H. LENDIO

RODNEY K. HARAGA, Ex-Officio
LARRY J. LEOPARDI, Ex-Officio

CLIFFORD S. JAMILE
Manager and Chief Engineer

DONNA FAY K. KIYOSAKI
Deputy Manager and Chief Engineer

Mr. Dennis R. Yoshimura
Independent Dealer Group
575 Cooke Street, Suite 2606
Honolulu, Hawaii 96813

Dear Mr. Yoshimura

Subject: Your Letter Dated October 2, 2003 Requesting Approval of Pratt & Lambert Products

We approve the following paint schedules for inclusion in the water system standards:

A. NEW SCHEDULE FOR NEW SURFACES

1. Ferrous Metals (Interior and Exterior)

PAINT SCHEDULE

Prime: 1 coat Poxy-Gard HB Aluminum Mastic S3508 (5.0-10.0 mils DFT).

Prime: 1 coat Poxy-Gard HB Expoy Mastic S3500 series (5.0-10.0 mils DFT).

Top Coat Enduthane HB Acrylic Urethane S2800 series (3.00-4.0 mils DFT).

2. Galvanized Metals (Interior and Exterior)

Prime: 1 coat Z1 Latex Wash Primer 1.0 mil DFT

Top Coat Enduthane HB Acrylic Urethane S2800 series (3.0-4.0 mils DFT)

4. Aluminum Surfaces

Prime: 1 coat Z1 Latex Wash Primer 1.0 mil DFT

Top Coat Enduthane HB Acrylic Urethane S2800 series (3.0-4.0 mils DFT)

11. Wood, Other than Mahogany or Hardwood (Interior)

Prime: Interior Oil Primer S8161 (1.7-mils DFT)

Two coats Pro-Hide Gold Interior Alkyd
S/gloss S8800 (2.1-mils DFT)

Two coats Red Seal Interior Oil Satin Enamel
S5700 series (2.1-mils DFT)

12. Mahogany & Hardwood (Interior)

One coat Tonetic Wood Stain (if desired)

One or two coats Varmor Urethane Clear finish
R10 gloss

**B. PAINT SCHEDULE FOR
EXISTING SURFACES**

2. Existing Concrete, Masonry and
Plaster (Exterior)

PAINT SCHEDULE

Prime: Pro-Hide Gold Int./Ext. Acrylic
Concrete & Stucco Primer Z6300 (3.2-mils
DFT)

Two coats Red Seal Ext. Latex Flat Z1900
series (1.2 DFT per coat)

3. Existing Concrete, Masonry &
Plaster (Reservoir Exterior)

Prime: Exterior Acrylic & Stucco Primer
Z6300 (3.2-mils DFT)

Two coats Pro-Hide Gold Exterior S/gloss
Z8600 series (1.4-milsDFT)

We disapprove the following paint schedules:

**A. NEW SCHEDULE FOR NEW
SURFACES**

6. Masonry Surfaces (Exterior)

PAINT SCHEDULE

Prime: Pro-Hide Silver Heavy Duty Block
Filler Z8465 (50-80 sq. ft. per gallon)

Topcoat: 2 coats Pro-Hide Gold Exterior latex
Flat Z8400 series (1.2 mils DFT per coat)

7. Masonry Surfaces (Interior)

Prime: Pro-Hide Silver Heavy Duty Block
Filler Z8465 (50-80 sq. ft. per gallon)

Two coats Tech-Gard Water Borne Epoxy
Z5300 series (1.5-2.0 mils DFT per coat)

8. Concrete Surfaces (Exterior)

Prime: Pro-Hide Silver Heavy Duty Block Filler Z8465 (50-80 sq. ft. per gallon)

Top coat Pro-Hide Gold Exterior latex Flat Z8400 series (1.2 mils DFT per coat)

9. Concrete Surfaces (Interior)

Prime: Pro-Hide Silver Heavy Duty Latex Block Filler Z8465 (50-80 sq. ft. per gallon)

Two coats Tech-Gard Water Borne Epoxy Z5300 series (1.5-2.0 mils DFT)

10. Wood (Exterior)

Prime: Pro-Hide Gold Exterior Alkyd Wood Primer Z8460 (1.1-mils DFT)

Two coats Enducryl DDTM Z2900 Series 1.5-2.0 Series (1.5 -2.0 DFT)

**B. PAINT SCHEDULE FOR
EXISTING SURFACES**

**1. Ferrous Metal Items (Interior and
Exterior-Rust Retained)**

PAINT SCHEDULE

Prime: Poxy-Gard rust Inhibitive Epoxy Primer S3301 series (3.0-6.0 mils DFT)

Topcoat Enduthane HB Urethane S2800 series (4.0-6.0-mils DFT)

If you have any questions, contact Jason Takaki at 748-5740.

Very truly yours,



HOWARD H. TANAKA, Head
Maintenance Unit – Engineering Branch

Enclosure

cc: Hawaii, Kauai, Maui Water Departments
Maintenance-Field, F. Fung, Darwin Ching, J. Takaki GS:st

BOARD OF WATER SUPPLY

CITY AND COUNTY OF HONOLULU
630 SOUTH BERETANIA STREET
HONOLULU, HI 96843



October 15, 2003

JEREMY HARRIS, Mayor

EDDIE FLORES, JR., Chairman
CHARLES A. STED, Vice-Chairman
JAN M.L.Y. AMII
HERBERT S.K. KAOPUA, SR.
DAROLYN H. LENDIO

RODNEY K. HARAGA, Ex-Officio
LARRY J. LEOPARDI, Ex-Officio

CLIFFORD S. JAMILE
Manager and Chief Engineer

DONNA FAY K. KIYOSAKI
Deputy Manager and Chief Engineer

TO: WHOM IT MAY CONCERN

FROM: 
CLIFFORD S. JAMILE

SUBJECT: REVISION TO THE WATER SYSTEM EXTERNAL CORROSION CONTROL
STANDARDS, VOLUME 3, DATED 1991

Effective January 1, 2004, the Board of Water Supply (BWS) will require the installation of cathodic protection systems in conjunction with all installations of ductile iron pipes, unless otherwise directed by the Manager. The requirements of Part 2, Section 1.2, Table 3 "Exterior Corrosion Control Requirements" will be revised to eliminate the corrosion rating based on the soil resistivity. The corrosion control requirements for ductile iron pipe installation shall be designed to a corrosion rating of 1. Construction plans with ductile iron pipe installations submitted to the BWS for review and approval prior to January 1, 2004, shall not require cathodic protection system unless otherwise instructed.

If you have any questions, please contact Jason Takaki at 748-5740.

cc: Kauai, Maui, Hawaii Water Departments

Customer Care
Maintenance-Field
D. Ching
F. Fung
J. Takaki

MD:st

BOARD OF WATER SUPPLY

CITY AND COUNTY OF HONOLULU
830 SOUTH BERETANIA STREET
HONOLULU, HI 96843



August 12, 2003

JEREMY HARRIS, Mayor *JMH*

EDDIE FLORES, JR., Chairman
CHARLES A. STED, Vice-Chairman
JAN M.L.Y. AMII
HERBERT S.K. KAOPUA, SR.
DAROLYN H. LENDIO

RODNEY K. HARAGA, Ex-Officio
LARRY J. LEOPARDI, Ex-Officio

CLIFFORD S. JAMLE
Manager and Chief Engineer

DONNA FAY K. KIYOSAKI
Deputy Manager and Chief Engineer

Mr. Calvin Okinaka, Branch Manager
Fluid Systems Hawaii, Inc.
96-1407 Waihona Place
Pearl City, Hawaii 96782

Dear Mr. Okinaka:

Subject: Your Letter Dated April 10, 2003 Requesting Approval of
Corrosion Resistant Coated Cor-Ten T-Bolts and Nuts

We approve the Cor-Ten T-bolts and nuts with corrosion resistant Tripac 2000 Blue Coating System by Tripac Fasteners, and the Cor-Blue T-bolts by NSS Industries for inclusion into the Water System Standards. The Tripac 2000 Blue coated Cor-Ten T-bolts and nuts and Cor-Blue T-bolts and nuts shall be used for underground mechanical joint installations.

If you have any questions, please contact Jason Takaki at (808)748-5740.

Very truly yours,

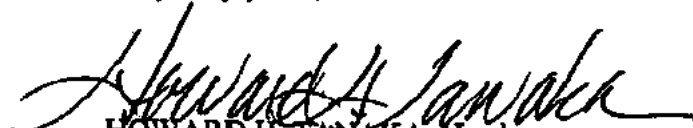
HOWARD H. TANAKA, Head
Maintenance Unit - Engineering

cc: County Depts. of Water
Maintenance Unit - Field
F. Fung
G. Matsunami
J. Takaki

FA:es

JT

BOARD OF WATER SUPPLY

CITY AND COUNTY OF HONOLULU
830 SOUTH BERETANIA STREET
HONOLULU, HI 96843



July 22, 2003

JEREMY HARRIS, Mayor

EDDIE FLORES, JR., Chairman
CHARLES A. STED, Vice-Chairman
JAN M.L.Y. AMHI
HERBERT S.K. KAOPUA, SR.
DAROLYN H. LENDIO

RODNEY K. HARAGA, Ex-Officio
LARRY J. LEOPARDI, Ex-Officio

CLIFFORD S. JAMILE
Manager and Chief Engineer

DONNA FAY K. KIYOSAKI
Deputy Manager and Chief Engineer

TO: WHOM IT MAY CONCERN

FROM: CLIFFORD S. JAMILE, MANAGER AND CHIEF ENGINEER
BOARD OF WATER SUPPLY

SUBJECT: WATER SYSTEM STANDARD AMENDMENT FOR NUTS AND BOLTS

Effective immediately, the Board of Water Supply (BWS) will allow the use of corrosion resistant coated Cor-Ten® T-Bolts and Nuts for underground mechanical joint installations in lieu of Type 316 stainless steel bolts and nuts as required in Division 200, Section 202.02, Mechanical Joint, of the 2002 Water System Standards (WSS). Until an amendment to the WSS Division 400, Section 402, Approved Material List, is approved to include Cor-Ten® T-Bolts and Nuts, material approvals shall be on a case-by-case basis. Materials shall be submitted to the BWS (Attn: Howard Tanaka) for review and approval.

If you have any questions, please contact Jason Takaki at 748-5740.

cc: Kauai, Maui, Hawaii Water Departments
Customer Care (J. Kaakua)
Maintenance-Field
G. Matsunami
F. Fung
J. Takaki

FA/JT:st

BOARD OF WATER SUPPLY

CITY AND COUNTY OF HONOLULU
630 SOUTH BERETANIA STREET
HONOLULU, HI 96843



June 20, 2003

JEREMY HARRIS, Mayor

EDDIE FLORES, JR., Chairman
CHARLES A. STED, Vice-Chairman
JAN M.L.Y. AMII
HERBERT S.K. KAOPUA, SR.
DAROLYN H. LENDIC

RODNEY K. HARAGA, Ex-Officio
LARRY J. LEOPARDI, Ex-Officio

CLIFFORD S. JAMILE
Manager and Chief Engineer

DONNA FAY K. KIYOSAKI
Deputy Manager and Chief Engineer

Mr. Joshua James Larkin
Romac Industries, Inc.
21919 20th Avenue SE, Suite 100
Bothell, Washington 98021

Dear Mr. Larkin:

Subject: Your Letter Dated April 15, 2003 Requesting Approval of Romac Style DJ 400 Ductile Iron Dismantling Joints

The Romac Style DJ 400 Ductile Iron Dismantling Joints, sizes 16-inch and larger are approved for inclusion into the Water System Standards.

If you have any questions, please contact Jason Takaki at (808)748-5741.

Very truly yours,

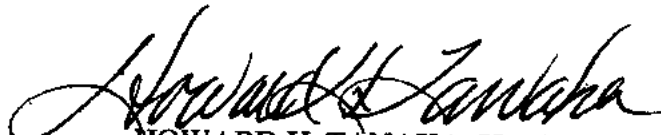
HOWARD H. TANAKA, Head
Maintenance Unit – Engineering

cc: County Departments of Water

Maint. Field, F. Fung, G. Matsunami, J. Takaki
FA:st

Supp

BOARD OF WATER SUPPLY

CITY AND COUNTY OF HONOLULU
630 SOUTH BERETANIA STREET
HONOLULU, HI 96843



May 23, 2003

JEREMY HARRIS, Mayor

EDDIE FLORES, JR., Chairman
CHARLES A. STED, Vice-Chairman
JAN M.L.Y. AMII
HERBERT S.K. KAOPUA, SR.
DAROLYN H. LENDIO

RODNEY K. HARAGA, Ex-Officio
LARRY J. LEOPARDI, Ex-Officio

CLIFFORD S. JAMILE
Manager and Chief Engineer

DONNA FAY K. KIYOSAKI
Deputy Manager and Chief Engineer

Mr. John Miller
The Sherwin-Williams Company
1311 Kalani Street
Honolulu, Hawaii 96817

Dear Mr. Miller:

Subject: Your Letter Dated December 23, 2002 Requesting Approval of
Sherwin Williams Coatings

We approve the following Sherwin Williams paint schedules for inclusion in the Water System Standards:

A. NEW SURFACES

PAINT SCHEDULES

- | | |
|--|--|
| 1. Ferrous Metals (Int. and Ext.) | Prime Coat: 1 coat Zinc Clad II HS (B69VZ3) @ 3-5 mils DFT
Intermediate: 1 coat Macropoxy 646 Fast Cure (B58-600 Series) @ 5-10 mils DFT
Finish Coat: 1 coat Hi-solids Polyurethane (B65-300 Series) @ 3-4 mils DFT |
| 2. Galvanized Metals (Int. and Ext.) | Prime Coat: 1 coat DTM Wash Primer (B71Y1) @ 0.7-1.3 mils DFT
Finish Coat: 1 coat Acrolon 218 HS Acrylic Polyurethan (B65-600 Series) @ 3-6 mils DFT |
| 3. Factory Finished Metals (Int. & Ext.) | Prime Coat: 1 coat W.B. Tile Clad Epoxy Primer (B73A200 Series) @ 2-4 Mils DFT
Finish Coat: 1 coat Centurion WB Urethane (B65-700 Series) @ 2-3 mils DFT, or 1 COAT Macropoxy HS (B58-400 Series) @ 3-6 mils DFT (B58-400 Series) |
| 4. Aluminum Surfaces | Prime 1 coat: DTM Wash Primer (B71Y1) @ 0.7-1.3 mils DFT
Finish Coat: 1 coat Corothane II Polyurethane (B65-200/400 Series) @ 2-4 mils DFT |

5. Masonry Surfaces (Exterior) Prime Coat: 1 coat Loxon Masonry Primer (A24 Series) @ 2.5-3.2 mils DFT.
Finish Coat: 2 coats DTM Acrylic (B66 Series) @ 2.5-4 mils DFT
6. Masonry Surfaces (Interior) Prime Coat: 1 coat Loxon Masonry Primer (A24 Series) @ 2.5-3.2 mils DFT.
Finish Coat: 2 coats DTM Acrylic (B66 Series) @ 2.5-4 mils DFT
7. Concrete Surfaces (Exterior) Prime Coat: 1 coat Loxon Block Surfacer (A24 Series) @ 2.5-3.2 mils DFT
Finish Coat: 2 coats DTM Acrylic (B66 Series) @ 2.5-4 mils DFT, or 2 coats W.B. Tile Clad Epoxy Finish (B73W111 Series) @ 2-4 Mils DFT
8. Concrete Surfaces (Interior) Prime Coat: 1 coat Loxon Block Surfaces (A24 Series) @ 2.5-3.2 mils DFT
Finish Coat: 2 coats DTM Acrylic (B66 Series) @ 2.5-4 mils DFT, or 2 coats W.B. Tile Clad Epoxy Finish (B73W111 Series) @ 2-4 Mils DFT
9. Wood (Exterior) Prime Coat: 1 coat A100 Alkyd Primer (Y24 Series) @ 2.3 mils DFT
Finish Coat: 2 coats A100 Latex (A6, A82, A8 Series) @ 1.2 mils DFT, or 2 coats DTM Acrylic (B66 Series) @ 2.5-4 mils DFT
10. Wood Other than Mahogany (Int.) Prime Coat: 1 coat PreRite Classic Int. Ltx. Primer (B28W101) @ 1.6 mils DFT
Finish Coat: 2 coats ProMar 200 Int. Ltx. Semi-Gloss (B31-200) @ 1.4 mils DFT
11. Mahogany (Interior Only) Prime Coat: 1 coat Wood Classic Stain (A49 Series)
Finish Coat: 2 coats Wood Classic Polyurethane (A67 Series) @ 1.7 mils DFT

B. EXISTING SURFACES

PAINT SCHEDULE

- | | |
|--|--|
| 1. Ferrous Metals (Interior & Exterior Rust Retained) | Prime Coat: 1 coat Macropoxy 920 PrePrime (B58T101) @ 1.5-2 mils DFT
Finish Coat: 1 coat HS Polyurethane (B65-300 Series) @ 3-4 mils DFT |
| 2. Concrete, Masonry, and Plaster (Exterior) | Prime Coat: WB Catalyzed Epoxy Ultradeep (B70200 Series) @ 2.5-3 mils DFT
Finish Coat: 2 coats A100 Ltx Acrylic (A6, A8, A82 Series) @ 1.2 mils DFT, or 2 coats DTM Acrylic (B66 Series) @ 2.4 mils DFT |
| 3. Concrete, Masonry, and Plaster (Reservoir Exterior) | Prime Coat: WB Catalyzed Epoxy Ultradeep (B70-200 Series) @ 2.5-3 mils DFT
Finish Coat: 2 coats A100 Ltx Acrylic (A6, A8, A82 Series) @ 1.2 mils DFT or 2 coats DTM Acrylic (B66 Series) @ 2.4 mils DFT |

We disapprove the treatment for reservoir interiors. The Board of Water supply does not paint the interior of its reservoirs as a standard practice.

If you have any questions, please contact Jason Takaki at 748-5741.

Very truly yours,



HOWARD H. TANAKA, Head
Maintenance Unit – Engineering

--
cc: Hawaii, Kauai, and Maui Water Departments
Maintenance – Field
G. Matsunami
F. Fung
Support Section

FA:em

Support

BOARD OF WATER SUPPLY

CITY AND COUNTY OF HONOLULU
630 SOUTH BERETANIA STREET
HONOLULU, HI 96843



May 12, 2003

JEREMY HARRIS, Mayor

EDDIE FLORES, JR., Chairman
CHARLES A. STED, Vice-Chairman
JAN M.L.Y. AMII
HERBERT S.K. KAOPUA, SR.
DAROLYN H. LENDIO

RODNEY K. HARAGA, Ex-Officio
LARRY J. LEOPARDI, Ex-Officio

CLIFFORD S. JAMILE
Manager and Chief Engineer

DONNA FAY K. KIYOSAKI
Deputy Manager and Chief Engineer

Mr. Teddy Pascual
FSC Coatings, Inc.
5360 Eastgate Mall Road, Suite F
San Diego, California 92121

Dear Mr. Pascual:

Subject: Your Letter Dated January 24, 2003 Requesting Approval of FSC High Performance Coatings

We approve the following paint schedules for inclusion in the water system standards:

A. NEW SURFACES

PAINT SCHEDULE

- 1. Ferrous Metals (Int. and Ext.)
 - Prime Coat: Zero-Rust Modified Phenolic Primer – Black (2.5 – 3.0 mils DFT)
 - Intermediate: Zero-Rust Modified Phenolic Primer – Red (2.5 –3.0 mils DFT)
 - Finish Coat: Silicone Polyplus Topcoat (Int.) (3.0 mils DFT). Silicone Polyplus Ultimate UV (Ext.) (3.0 mils DFT).

- 2. Galvanized Metals (Int. and Ext.)
 - Prep: Zero-Rust Prep Step Concentrate.
 - Prime Coat: Zero-Rust Modified Phenolic Primer – Black (2.5 – 3.0 mils DFT)
 - Intermediate: Zero-Rust Modified Phenolic Primer – Red (2.5 –3.0 mils DFT)
 - Finish Coat: Silicone Polyplus Topcoat (Int.) (3.0 mils DFT). Silicone Polyplus Ultimate UV (Ext.) (3.0 mils DFT).

3. **Factory Finished Metals (Int. & Ext.)**
Prep: Zero-Rust Prep Step Concentrate.
Prime Coat: Zero-Rust Modified Phenolic Primer – Black (2.5 – 3.0 mils DFT)
Finish Coat: Silicone Polyplus Topcoat (Int.) (3.0 mils DFT). Silicone Polyplus Ultimate UV (Ext.) (3.0 mils DFT).
4. **Aluminum Surfaces**
Prep: FSC Wax and Grease Remover
Prime Coat: Zero-Rust Modified Phenolic Primer – Black (2.5 – 3.0 mils DFT)
Finish Coat: Silicone Polyplus Topcoat (Int.) (3.0 mils DFT).
5. **Masonry Surfaces (Exterior)**
Prime Coat: FSC Mildew Sealer
Intermediate: Maxlife 2400 Series/2800 Series.
Finish Coat: Maxlife 2400 Series/2800 Series.
6. **Masonry Surfaces (Interior)**
Prime Coat: FSC Prime and Seal.
Intermediate: Maxlife 2400 Series/2800 Series.
Finish Coat: Maxlife 2400 Series/2800 Series.
7. **Concrete Surfaces (Exterior)**
Prime Coat: FSC Mildew Sealer
Intermediate: Maxlife 2400 Series/2800 Series.
Finish Coat: Maxlife 2400 Series/2800 Series.
8. **Concrete Surfaces (Interior)**
Prime Coat: FSC Prime and Seal.
Intermediate: Maxlife 2400 Series/2800 Series.
Finish Coat: Maxlife 2400 Series/2800 Series.
9. **Wood (Exterior)**
Prime Coat: Silicone Polyplus (1.5 – 2.0 mils DFT)
Intermediate: Silicone Polyplus (1.5 – 2.0 mils DFT)
Finish Coat: Silicone Polyplus Topcoat Ultimate UV (3.0 mils DFT)
10. **Wood Other than Mahogany (Int.)**
Prime Coat: Silicone Polyplus (1.5 – 2.0 mils DFT)
Intermediate: Silicone Polyplus (1.5 – 2.0 mils DFT)
Finish Coat: Silicone Polyplus Topcoat (3.0 mils DFT)
11. **Mahogany (Interior Only)**
Prime Coat: TWP 300 Series/400Series
Finish Coat: FSC Quick Dry Varnish

B. EXISTING SURFACES

1. Ferrous Metals (Interior & Exterior Rust Retained)
Prime Coat: Zero-Rust Modified Phenolic Primer – (2.5 mils DFT)
Intermediate: Zero-Rust Modified Phenolic Primer – (2.5 mils DFT)
Finish Coat: Silicone Polyplus Topcoat (Int.) (3.0 mils DFT). Silicone Polyplus Ultimate UV (Ext.) (3.0 mils DFT).
2. Concrete, Masonry, and Plaster (Exterior)
Prep: Silox-Seal Part "A"
Prime Coat: FSC Modified Mildew Sealer
Intermediate: Maxlife Series PC550
Finish Coat: Maxlife Series PC550
3. Concrete, Masonry and Plaster (Reservoir Exterior)
Prep: Silox-Seal Part "A"
Prime Coat: FSC Modified Mildew Sealer
Intermediate: Maxlife Series PC550
Finish Coat: Maxlife Series PC550

We disapprove the Anti-Graffiti paint schedule for use in the Water System. The Board of Water Supply does not paint the exterior of its facilities with anti-graffiti coating at this time.

If you have any questions, contact Jason Takaki at (808) 748-5741.

Very truly yours,



HOWARD H. TANAKA, Head
Maintenance Unit - Engineering

cc: Hawaii, Kauai, and Maui Water Departments
Maint. – Field
G. Matsunami
F. Fung
Support

FA:em

BOARD OF WATER SUPPLY

CITY AND COUNTY OF HONOLULU
630 SOUTH BERETANIA STREET
HONOLULU, HI 96843



March 24, 2003

JEREMY HARRIS, Mayor *JH*

EDDIE FLORES, JR., Chairman
CHARLES A. STED, Vice-Chairman
JAN M.L.Y. AMII
HERBERT S.K. KAOPUA, SR.
DAROLYN H. LENDIO

RODNEY K. HARAGA, Ex-Officio
LARRY J. LEOPARDI, Ex-Officio

CLIFFORD S. JAMILE
Manager and Chief Engineer

DONNA FAY K. KIYOSAKI
Deputy Manager and Chief Engineer

Mr. Dennis Graham
Valve Service & Supply
91-210 Olai Street
Kapolei, HI 96707

Dear Mr. Graham:

Subject: PowerSeal Transition Couplings

The following PowerSeal Transition Couplings will not be allowed for use in our water system and will be removed from the Approved Material List of the Water System Standards:

Styles 3501, 3502, 3503, 3504, 3511, and 3512.

Samples representing the current shipment of the Style 3501 couplings show casting defects at critical locations that would impair their service in the water system.

Please remove the shipment of the Style 3501 couplings completely from the Board of Water Supply yard at your own expense. We will evaluate any future approval request to use the PowerSeal Couplings in the water system once the casting problem has been resolved.

If you have any questions, contact Jason Takaki at 748-5741.

Very truly yours,

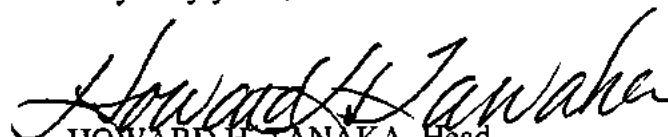
HOWARD H. TANAKA, Head
Maintenance Unit - Engineering

cc: PowerSeal
Maintenance - Field
F. Fung
G. Matsunami
J. Takaki

Support

BOARD OF WATER SUPPLY

CITY AND COUNTY OF HONOLULU
630 SOUTH BERETANIA STREET
HONOLULU, HI 96843



JEREMY HARRIS, Mayor
EDDIE FLORES, JR., Chairman
CHARLES A. STED, Vice Chairman
JAN M.L.Y. AMII
HERBERT S.K. KAOPUA, SR.
DAROLYN H. LENDIO

BRIAN K. MINAAI, Ex-Officio

CLIFFORD S. JAMILE
Manager and Chief Engineer

DONNA FAY K. KIYOSAKI
Deputy Manager and Chief Engineer

November 27, 2002

Mr. John L. Hawkins
James Jones Company
4127 Temple City Boulevard
El Monte, California 91731

Dear Mr. Hawkins:

Subject: Your Letter Dated October 8, 2002 Requesting Approval of
James Jones Company's Service Saddles, Couplings and Ball Valves

We approve the following materials for inclusion into our Water System Standards:

James Jones Compression Couplings: Models J-2605, J-2607, and J-2609.

James Jones Ball Valves: Model J-1905.

James Jones Meter Coupling: Model J-130.

The Ball Valve Model J-1905, when used as property valve, should be provided with a handle that would fit inside the required Type "A" or Type "B" box.

The Service Saddle, Model J-979, has already been approved and included in the Approved Material List of the Water System Standards (Refer to enclosed approval letter dated April 8, 1987).

If you have any questions, please contact Jason Takaki at 527-6196.

Very truly yours,

HOWARD H. TANAKA, Head
Maintenance Unit - Engineering

Enclosure
cc: Hawaii, Kauai, and Maui DWS

G. Matsunami, F. Fung, Support FA:st

Frank/ file KK

April 8, 1987

Mr. Harry Imai
Fluid Systems Hawaii, Inc.
96-1407 Waihona Place
Pearl City, Hawaii 96782

Dear Mr. Imai:

Subject: Your Letter of March 23, 1987 Requesting Additions
and Amendments to the Approved Material List of the
1985 Water System Standards

We approve the Mueller Company H-619 Tapping Valve and Sleeve for asbestos-cement pipe and James Jones J-979 Bronze Double Strap Service Saddle for ductile iron and asbestos-cement pipes for use in our water system.

Our comments regarding the rest of your fittings will be sent to you by April 30, 1987.

If you have any questions, please contact Kenneth Kawamoto at 527-6144.

Very truly yours,

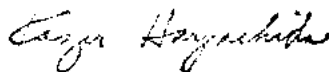

KAZU HAYASHIDA
Manager and Chief Engineer

FI:ki

cc: K. Hayashida
Finance
Field Operations
J. Yamauchi
R. Matsui
D. Ching
~~K. Kawamoto~~

BOARD OF WATER SUPPLY

CITY AND COUNTY OF HONOLULU
630 SOUTH BERETANIA STREET
HONOLULU, HI 96843



JEREMY HARRIS, Mayor

EDDIE FLORES, JR., Chairman
CHARLES A. STED, Vice Chairman
JAN M.L.Y. AMI
HERBERT S.K. KAOPUA, SR.
DAROLYN H. LENDIO

BRIAN K. MINAAI, Ex-Officio

November 22, 2002

CLIFFORD S. JAMILE
Manager and Chief Engineer

DONNA FAY K. KIYOSAKI
Deputy Manager and Chief Engineer

Fluid Systems Hawaii, Inc.
96-1407 Waihona Place
Pearl City, Hawaii 96782

Attention: Mr. Calvin Okinaka

Gentlemen:

Subject: Globe Valves for Property Valves

Henceforth, the Honolulu Board (BWS) of Water Supply will require the use of globe valves for property valves.

Attached is the list of approved globe valves. However, the BWS is still considering switching to ball valves with handles when a suitable design that would fit inside the Type "A" valve box is available.

If you have any questions, please contact Jason Takaki at 527-6196.

Very truly yours,

A handwritten signature in black ink, reading "Howard H. Tanaka". The signature is fluid and cursive, with the first letters of the first and last names being capitalized and prominent.

HOWARD H. TANAKA, Head
Maintenance Unit – Engineering

Enc.

FA:em

cc: Maintenance – Field
Customer Care (J. Kaakua, D. Shimizu)
F. Fung
J. Takaki
G. Matsunami
Support Section

APPROVED GLOBE VALVES FOR OAHU ONLY

<u>Manufacturer</u>	<u>Catalog or Model No.</u>
Globe Valves	
A. 125-Pound Steam	
1. Crane Co.	Model 1, Bronze
2. Fairbanks	Model 45 & U-01
3. Hammond Valve Corp.	Model 440
4. Kennedy	Catalog 86, Model 150
5. A.Y. McDonald Mfg. Co.	Catalog PB-73, Model 9510
6. Milwaukee Valve Corp.	Catalog I172, Model 502
7. Nibco	T-211-B
8. Ohio Brass Co.	Catalog 58, Models 101, 30I-T
9. Ohio Injector Co.	Catalog 53, Model 234
10. Powell	Catalog 11, Model 650
11. Red & White Valve Co.	Catalog C/I, Model 211
12. (Stockham) Crane Co.	Catalog 57, Model B-16
	Model B-13T
13. Walworth	Catalog 52, Model 58
B. 150-Pound Steam	
1. Lunkenheimer	Catalog 66, Model 123 (No. 20 disc.)
2. Nibco	T-235

BOARD OF WATER SUPPLY

CITY AND COUNTY OF HONOLULU
630 SOUTH BERETANIA STREET
HONOLULU, HI 96843



July 11, 2002

JEREMY HARRIS, Mayor

EDDIE FLORES, JR., Chairman
CHARLES A. STED, Vice-Chairman
JAN M.L.Y. AMII
HERBERT S.K. KAOPIA, SR.

BRIAN K. MINAAI, Ex-Officio
ROSS S. SASAMURA, Ex-Officio

CLIFFORD S. JAMILE
Manager and Chief Engineer

Mr. Jose A. Casarez
Pittsburgh Paint Center
425 Kalihi Street
Honolulu, Hawaii 96819

Dear Mr. Casarez:

Subject: Your Letter Dated May 13, 2002 Requesting
Approval of PPG Industries High Performance Products

We approve the following paint schedules for inclusion in the water system standards:

A. NEW SURFACES

PAINT SCHEDULE

- | | | |
|----|---------------------------------------|--|
| 1. | Ferrous Metals (Int. and Ext.) | Prime Coat: PPG 95-245 PITTGUARD Direct-to-rust Epoxy Coating @ 5.0 to 7.0 mils DFT.

Finish Coat: PPG 95-850 PITTHANE 35 Aliphatic Urethane Gloss Enamel @ 2.0 to 3.0 mils DFT. |
| 2. | Galvanized Metals (Int. and Ext.) | Prime Coat: PPG 95-245 PITTGUARD Direct-to-rust Epoxy Coating @ 5.0 to 7.0 mils DFT.

Finish Coat: PPG 95-850 PITTHANE 35 Aliphatic Urethane Gloss Enamel @ 2.0 to 3.0 mils DFT. |
| 3. | Factory Finished Metals (Int. & Ext.) | Prime Coat: PPG 95-245 PITTGUARD Direct-to-rust Epoxy Coating @ 5.0 to 7.0 mils DFT.

Finish Coat: PPG 95-850 PITTHANE 35 Aliphatic Urethane Gloss Enamel @ 2.0 to 3.0 mils DFT. |

4. Aluminum Surfaces
Pretreatment: In accordance with SSPC SP1

Prime Coat: PPG 95-245 PITTGUARD Direct-to-rust Epoxy Coating @ 5.0 to 7.0 mils DFT.

Finish Coat: PPG 95-850 PITTHANE 35 Aliphatic Urethane Gloss Enamel @ 2.0 to 3.0 mils DFT.
5. Masonry Surfaces (Exterior)
Prime Coat: PPG 6-7 SPEEDHIDE Interior/Exterior Acrylic Masonry Block Filler @ 4.8 to 14.0 mils DFT

Finish Coat: Two coats PPG 78-45 SUN-PROOF Exterior 100% Acrylic Semi-Gloss House and Trim Paint @ 1.5 to 2.0 mils DFT.
6. Concrete Surfaces (Exterior)
Prime Coat: PPG 98-46 AQUAPON WB Water Based Epoxy Primer Coating @ 3.0 to 4.0 mils DFT.

Finish Coat: PPG 78-45 SUN-PROOF Exterior 100% Acrylic Semi-Gloss House and Trim Paint @ 1.5 to 2.0 mils DFT.
7. Wood (Exterior)
Prime Coat: PPG 6-809 SPEEDHIDE Exterior Alkyd Wood Primer @ 1.5 to 2.0 mils DFT.

Finish Coat: PPG 90-374 PITTECH Interior/ Exterior Waterborne DTM Industrial High Gloss Enamel @ 2.0 to 3.0 mils DFT.
8. Mahogany (Interior Only)
Prime Coat: PPG 77-30 REZ Interior QD Wood Sanding Sealer @ .5 to 1.0 mils DFT.

Finish: PPG 77-10 REZ Interior/Exterior Alkyd Spar Varnish @ 1.10 to 1.5 mils DFT.

B. EXISTING SURFACES

1. Ferrous Metals (Interior & Exterior Rust Retained) Prime Coat: PPG 95-245 PITTGUARD Direct-to-rust Epoxy Coating @ 5.0 to 7.0 mils DFT.
Finish Coat: PPG 95-850 PITTHANE 35 Aliphatic Urethane Gloss Enamel @ 2.0 to 3.0 mils DFT.

We had previously approved the following paint schedules in the attached letter dated April 9, 2002:

A. NEW SURFACES

PAINT SCHEDULE

1. Masonry Surfaces Interior Prime Coat: PPG 16-90 PITT-GLAZE Interior/Exterior Acrylic Block Filler @ 12.0 to 25.0 mils DFT.
Finish Coat: Two coats PPG 98-1 AQUAPON Waterborne Polyamide Epoxy @ 2.0 to 3.0 mils DFT.
2. Concrete Surfaces (Interior) Prime Coat: PPG 16-90 PITT-GLAZE Interior/Exterior Acrylic Block Filler @ 12.0 to 25.0 mils DFT.
Finish Coat: Two coats PPG 98-1 AQUAPON Waterborne Polyamide Epoxy @ 2.0 to 3.0 mils DFT.
3. Wood Other than Mahogany (Int.) Prime Coat: PPG 6-6 SPEEDHIDE Interior Alkyd Enamel Undercoater @ 1.8 to 2.2 mils DFT.
Finish Coat: Two coats PPG 6-1110 SPEEDHIDE Interior Semi-Gloss Alkyd Enamel @ 1.8 to 2.2 mils DFT.

B. EXISTING SURFACES

1. Concrete, Masonry, and Plaster (Exterior) Prime Coat: PPG 6-603 SPEEDHIDE Interior/ Exterior Acrylic Alkali Resistant Primer @ 1.2 to 1.5 mils DFT.
Finish Coat: Two coats PPG 6-900 SPEEDHIDE Exterior Semi-Gloss Latex @ 1.2 to 1.5 mils DFT.

2. Concrete, Masonry and Plaster (Reservoir Exterior) Prime Coat: PPG 6-603 SPEEDHIDE Interior/ Exterior Acrylic Alkali Resistant Primer @ 1.2 to 1.5 mils DFT.
- Finish Coat: Two coats PPG 6-900 SPEEDHIDE Exterior Semi-Gloss Latex @ 1.2 to 1.5 mils DFT.

As stated in our letter of April 9, 2002, we disapprove the paint schedules for Concrete Reservoir (Interior) and Anti-Graffiti. As standard practice, we do not paint the interior of reservoirs or the exterior of our facilities with anti-graffiti coatings at this time.

If you have any questions, contact Jason Takaki at 527-6196.

Very truly yours,

HOWARD H. TANAKA, Head
Maintenance Unit - Engineering

Enclosure (Letter dated 4/9/02)

cc: Hawaii, Kauai, and Maui Water Departments
Maintenance - Field
G. Matsunami
F. Fung
Support

BOARD OF WATER SUPPLY

CITY AND COUNTY OF HONOLULU
630 SOUTH BERETANIA STREET
HONOLULU, HI 96843



JEREMY HARRIS, Mayor

EDDIE FLORES, JR., Chairman
CHARLES A. STED, Vice-Chairman
JAN M.L.Y. AMII
HERBERT S.K. KAOPIA, SR.

BRIAN K. MINAAI, Ex-Officio
ROSS S. SASAMURA, Ex-Officio

CLIFFORD S. JAMILE
Manager and Chief Engineer

April 9, 2002

Mr. Dan Davis
PPG Industries, Inc.
24832 San Doval Lane
Mission, Viejo, CA 92691

Dear Mr. Davis:

Subject: Your Letter Dated November 2, 2001 Requesting
Approval of PPG Industries High Performance Coatings

We approve the following paint schedules for inclusion into the Water System Standards:

1. Paint Schedule for New Surfaces
 - a. Schedule 7 – Masonry Surfaces: (Interior)
 - b. Schedule 9 – Concrete Surfaces: (Interior)
 - c. Schedule 11 – Wood, Other than Mahogany or Hardwood: (Interior)
2. Paint Schedule for Existing Surfaces
 - a. Schedule 2 – Existing Concrete, Masonry and Plaster: (Exterior)
 - b. Schedule 3 – Existing Concrete, Masonry and Plaster: (Reservoir Exterior)

We disapprove the following paint schedules:

1. Paint Schedule for New Surfaces
 - a. Schedule 5 – Overflow Pipe. The paint specified is not recommended for use for potable water.
 - b. Schedule 13 – Concrete Reservoir: (Interior). The interior of concrete reservoirs is not painted as a standard practice.
2. Remaining Paint Schedules
 - a. Schedules 1, 2, 3, 4, 6, 8, 10, 12 & 14 for New Surfaces and Schedule 1 for Existing Surfaces. The Technical Data Sheets for the finish coats list a recommended primer; the prime coat selected in the paint schedules is not listed as one of the recommended primers.

Mr. Dan Davis
PPG Industries, Inc.
April 9, 2002
Page 2

If you have any questions, contact Jason Takaki at (808)527-6196.

Very truly yours,

A handwritten signature in cursive script, reading "Howard H. Tanaka".

HOWARD H. TANAKA, Head
Maintenance Unit - Engineering