

Red Hill Bulk Fuel Storage Facility Final Groundwater Protection Plan

Pearl Harbor, Hawaii

January 2008

Prepared for:
Department of the Navy, Commander
Naval Facilities Engineering Command, Pacific
Pearl Harbor, HI 96860-3134



Indefinite Delivery/ Indefinite Quantity Contract
Contract Number N62742-02-D-1802, CTO 007

Red Hill Bulk Fuel Storage Facility Final Groundwater Protection Plan

Pearl Harbor, Hawaii

January 2008

Prepared for:



**Department of the Navy, Commander
Naval Facilities Engineering Command, Pacific
258 Makalapa Drive, Suite #100
Pearl Harbor, HI 96860-3134**

Prepared by:

**TEC Inc.
1001 Bishop Street
American Savings Bank Tower, Suite 1400
Honolulu, HI 96813**

Prepared under:

**Indefinite Delivery/ Indefinite Quantity Contract
Contract Number N62742-02-D-1802, CTO 007**

TABLE OF CONTENTS

	Page
EXECUTIVE SUMMARY	1
1 INTRODUCTION.....	1-1
1.1 Description of the Facility	1-1
1.2 Description of the Problem	1-2
1.3 Groundwater Protection Plan Scope and Objectives	1-3
1.4 Groundwater Protection Plan Updates	1-4
1.5 Navy Region Hawaii Integrated Contingency Plan	1-4
1.6 Water System Emergency Response Plan	1-4
1.7 Conceptual Site Model and Risk.....	1-4
1.7.1 Description of the Facility	1-5
1.7.2 Nature and Extent of Contamination	1-6
1.7.2.1 Rock Boring Sample Results.....	1-6
1.7.2.2 Groundwater Sample Results	1-6
1.7.2.3 Soil Vapor Sample Results.....	1-6
1.7.3 Comprehensive Conceptual Site Model.....	1-7
1.7.3.1 Groundwater Usage.....	1-8
1.7.3.2 Contaminant Fate and Transport and Groundwater Modeling.....	1-8
1.7.3.3 Risk Summary	1-10
2 APPLICABLE REGULATIONS AND GUIDANCE	2-1
2.1 Federal Regulations and Guidance	2-1
2.1.1 Drinking Water and Potable Water Systems.....	2-1
2.1.2 USTs	2-1
2.1.2.1 Regulations Applicable to the Facility	2-1
2.1.2.2 Regulations “To Be Considered” at the Facility	2-2
2.2 Hawaii Regulations and Guidance.....	2-3
2.2.1 Drinking Water and Potable Water System Regulations	2-3
2.2.2 Hawaii Environmental Response Law and State Contingency Plan Regulations.....	2-3
2.2.3 UST Regulations.....	2-4
2.2.4 EALs as “To Be Considered” Guidance	2-4
2.3 Non-Regulatory Guidance on Release Detection To Be Considered for the Facility.....	2-7
2.3.1 Alternative Leak Detection Methods for Bulk Field Constructed Tanks	2-7
2.4 Regulatory History of the Facility	2-8
3 TANK PREVENTIVE MAINTENANCE AND LEAK MONITORING PROGRAM.....	3-1
3.1 Tank Maintenance and Repair Program.....	3-2
3.1.1 Tank Maintenance and Repair Histories.....	3-2
3.1.2 Tank Inspections and Repairs	3-5
3.1.3 Current Status of the USTs	3-6
3.2 Current Petroleum Release Monitoring Systems	3-6
3.2.1 Soil Vapor Monitoring System	3-6
3.2.2 Groundwater Monitoring at the Facility	3-7
3.3 Ongoing Groundwater Protection Activities.....	3-7
3.3.1.1 Reporting Tank Inspections, Leaks, and Releases to HDOH.....	3-8
4 GROUNDWATER MONITORING PROGRAM, EVALUATION OF RESULTS, AND RESPONSE ACTIONS	4-1
4.1 Groundwater Monitoring Program.....	4-1
4.1.1 Regulatory Requirements	4-1

4.1.2	Groundwater Monitoring Network	4-1
4.1.3	Groundwater Sampling and Analysis Protocol.....	4-2
4.2	Groundwater Analytical Results	4-2
4.3	Groundwater Action Levels	4-3
4.3.1	STEP 1: Compare Analytical Results to Action Levels and Conduct Trend Evaluation	4-3
4.3.2	STEP 2: Take Actions for Results That Exceed the Specified Action Levels.....	4-4
4.4	Responsibilities	4-6
5	CONTINGENCIES FOR CONTAMINATION OF POTABLE WATER.....	5-1
5.1	Potential Alternative Sources of Potable Water.....	5-1
5.2	Water Treatment Options.....	5-1
5.2.1	Summary of Potable Water Treatment Facility Technologies.....	5-3
5.2.2	Summary of Groundwater Treatment Technologies.....	5-3
5.2.2.1	Pump and Treat Evaluation	5-4
5.2.2.2	Enhanced Bioremediation Evaluation	5-5
6	REFERENCES.....	6-1

LIST OF TABLES

Table 1-1. Total Soil Vapor	1-7
Table 2-1. Reporting Requirements for UST Release Response	2-6
Table 3-1. Tank Inspections and Scheduling	3-9
Table 4-1. Action Levels.....	4-4
Table 4-2. Responses to Groundwater Monitoring Results	4-5
Table 4-3. Navy Chain of Command and Responsibilities for Implementing the Groundwater Protection Plan	4-7
Table 5-1. Summary of Pearl Harbor Water System	5-2
Table 5-2. Summary of Pearl Harbor Water System Components	5-2

LIST OF FIGURES

Figure 1-1 Regional Location Map.....	1-11
Figure 1-2 Site Plan Map	1-12
Figure 1-3 Area Wells and Aquifer Systems	1-13
Figure 1-4 Project Well Location Map	1-14
Figure 1-5 Conceptual Site Model.....	1-15
Figure 5-1 Pearl Harbor Water System Schematic	5-7

LIST OF APPENDICES

Appendix A Hawaii Department of Health Correspondence
Appendix B Modified API 653 Tank Inspection Procedure Completed Forms
Appendix C Groundwater Monitoring Field Sampling and Analysis Plan
Appendix D HDOH Quarterly Deliverables Examples
Appendix E Groundwater Treatment Technologies

LIST OF ACRONYMS AND ABBREVIATIONS

3-D	Three Dimensional	gpm	Gallons per minute
AFHAC	Automatic Fuel Handling and Control	HAR	Hawaii Administrative Rules
AFHE	Automatic Fuel Handling Equipment	HBWS	Honolulu Board of Water Supply
AMEC	AMEC Earth and Environmental, Inc.	HDOH	Hawaii Department of Health
AOR	Area of Responsibility	HERL	Hawaii Environmental Response Law, UST Program
API	American Petroleum Institute	HI	Hawaii
ATG	Automatic Tank Gauging	HPWS	Hawaii Potable Water Systems
AVGAS	Aviation gas	ICP	Integrated Contingency Plan
bgs	Below ground surface	ICS	Incident Command System
BTEX	Benzene, Toluene, Ethylbenzene, Xylene	JP	Jet Propulsion
CAP	Corrective Action Plan	JP-5	Jet Propulsion fuel 5
CERCLA	Comprehensive Environmental Response, Compensation, and Liability Act	JP-8	Jet Propulsion fuel 8
CFR	Code of Federal Regulations	KWA	Ken Wilcox Associates, Inc.
COMNAV	Commander, Navy Region	LNAPL	Light Non-Aqueous Phase Liquid
REG HI	Hawaii	LRDP	Low Range Differential Pressure
COPC	Constituent of Potential Concern	LUST	Leaking Underground Storage Tank
CSM	Conceptual Site Model	MCL	Maximum Contaminant Level
CTO	Contract Task Order	Mgal	Million gallons
DoN	Department of the Navy	mgd	Million gallons per day
EAL	Environmental Action Level (State of Hawaii)	mg/L	Milligrams per liter
EPC	Exposure Point Concentration	mL/hour	Milliliters per hour
EPH	Extractable Petroleum Hydrocarbon	µg/L	Micrograms per liter
°F	Degrees Fahrenheit	MOGAS	Motor gas
F-76	Marine diesel fuel	MP	Monitoring Point
FIC	Facility Incident Commander	msl	Mean sea level
FIMP	Fuel Integrity Management Program	MtBE	Methyl tert butyl ether
FISC	Fleet and Industrial Supply Center	MTG-TGI	Mass Tank Gauging – Tank Gauging Interface
FSP	Field Sampling Plan	NA	Not Applicable
GAC	Granular Activated Carbon	NAVFAC	Naval Facilities Engineering Command
gpd	Gallons per day	NCP	National Contingency Plan
gph	Gallons per hour	ND	Navy Distillate
		NELAC	National Environmental Laboratory Accreditation Conference

NFESC	Naval Facilities Engineering Service Center	SPAWAR	Navy Space and Naval Warfare Center
NOSC	Navy On-Scene Coordinator	SSRBL	Site-Specific, Risk-Based Levels
NPL	National Priorities List		
NPDW	National Primary Drinking Water	SVMP	Soil Vapor Monitoring Point
		SVMS	Soil Vapor Monitoring System
NSFO	Navy Special Fuel Oil	SVOC	Semi-Volatile Organic Compound
OHS	Oil and Hazardous Substances		
PACDIV	Pacific Division	SPCC	Spill Prevention Control and Countermeasure
PAH	Polynuclear Aromatic Hydrocarbons	SWAP	Source Water Assessment Program
PD	Probability of Detection		
PFA	Probability of False Alarm	TCE	Trichloroethylene
PHWS	Pearl Harbor Water System	TEC	TEC, Inc.
PIE	Precision Instrumentation Equipment	TGM	Technical Guidance Manual
PIMP	Pipeline Integrity Management Program	TGM-UST	Technical Guidance Manual for UST Closure and Release Response
POE	Point of Entry	TIMP	Tank Integrity Management Program
POL	Petroleum, Oils, and Lubricants		
ppbV	Parts per billion, Vapor	TPH-DRO	Total Petroleum Hydrocarbons, Diesel Range Organics
PRG	Preliminary Remediation Goal		
PWS	Public Works Center	TPH-GRO	Total Petroleum Hydrocarbons, Gasoline Range Organics
RBAL	Risk Based Action Levels		
RCRA	Resource Conservation and Recovery Act	TVH	Total Volatile Hydrocarbons
RFS	Removed From Service	UH	University of Hawaii
The Facility	Red Hill Fuel Storage Facility	UIC	Underground Injection Control
SAP	Sampling and Analysis Plan	U.S.	United States
SARA	Superfund Amendments and Reauthorization Act	USEPA	United States Environmental Protection Agency
SCP	State Contingency Plan	UST	Underground Storage Tank
SDG	Sample Delivery Group	UV	Ultraviolet
SDWA	Safe Drinking Water Act	VOC	Volatile Organic Compound
SDWB	Safe Drinking Water Branch	VPH	Volatile Petroleum Hydrocarbons
SI	Site Investigation		

This page intentionally left blank.

EXECUTIVE SUMMARY

This Groundwater Protection Plan was developed to mitigate the risk associated with inadvertent releases of fuel from the United States (U.S.) Navy Red Hill Bulk Fuel Storage Facility, Oahu, Hawaii (the Facility). Previous environmental Site Investigations (SIs) at the Facility showed that past inadvertent releases have contaminated the fractured basalt, basal groundwater, and soil vapor beneath the Facility with petroleum hydrocarbons. In response to these findings, the State of Hawaii Department of Health (HDOH) requested that the U.S. Navy:

- Conduct a detailed environmental SI at the Facility;
- Develop a groundwater model of the surrounding aquifers to evaluate the risk associated with petroleum releases to the groundwater; and
- Prepare a contingency plan to protect the U.S. Navy well 2254-01, which lies down gradient from the Facility and provides drinking water to the U.S. Navy Pearl Harbor Water System (PHWS).

The Facility consists of 20 underground storage tanks (USTs), each with the capacity to hold 12.5 million gallons (Mgal) of petroleum-based fuel as a reserve for the U.S. Navy Pacific Fleet. It was constructed in the field, entirely underground within the Red Hill Ridge for security and confidentiality reasons and was activated in 1943 to maintain the war effort. At the same time, the U.S. Navy well 2254-01 was installed approximately 3,000 feet downgradient from the Facility, and included a water tunnel, known as an infiltration gallery, which extends across the water table to within 1,560 feet of the Facility. The U.S. Navy well 2254-01 currently provides approximately 24 percent of the potable water to the PHWS, which serves approximately 52,200 military consumers. Model simulations of the measured contaminant concentrations beneath the Facility did not show contaminants entering the infiltration gallery at measurable concentrations. However, similar simulations showed hypothetical future releases of the jet propellant (JP-5 and JP-8) most commonly stored in the Facility USTs had the potential to contaminate the water that enters the infiltration gallery, if they are not identified quickly. In addition, the SI concluded that the aging of the Facility will increase the possibility that such a release could occur as a result of leaks breaching both the steel liners and concrete containment of the tanks. While the tank steel liners have been repaired, the concrete containment cannot be maintained.

Both the Facility and the U.S. Navy well 2254-01 are critical to the mission of the U.S. Navy in the Pacific and there are no alternative facilities to replace them. This Groundwater Protection Plan presents a strategy for ensuring that both the Facility and the U.S. Navy well 2254-01 can continue to operate at optimum efficiency into the future. This Groundwater Protection Plan focuses on long-term mitigation. It is not an emergency response plan.

The Facility USTs are deferred from many of the Federal and State UST regulations, including the requirement for release detection, because they are field constructed bulk fuel tanks. However, following the notification of releases from the Facility, HDOH strongly recommended

the installation of a leak detection system to protect U.S. Navy well 2254-01. Due to the importance of the groundwater resource, the U.S. Navy has evaluated methods to detect leaks at the Facility in the past and continues to do so. A final recommendation is expected in FY2008.

In addition, the U.S. Navy has installed three groundwater monitoring wells within the lower access tunnel of the Facility and conducted a soil vapor monitoring pilot study under seven of the 18 active USTs. In accordance with this Groundwater Protection Plan, the U.S. Navy has implemented a groundwater monitoring program in which groundwater samples are collected quarterly from three groundwater monitoring wells installed in the Facility lower access tunnel and the U.S. Navy well 2254-01. Samples are analyzed for specific petroleum compounds and mixtures in accordance with the HDOH EALs (HDOH, 2005). The U.S. Navy will:

- Maintain a complete database of chemical results from the groundwater sampling events;
- Evaluate concentration trends for chemicals of concern over time, evaluate chemical concentrations with respect to HDOH drinking water EALs;
- Monitor the groundwater for concentrations that may indicate that liquid fuel may be in direct contact with groundwater beneath the tanks; and
- Submit concentration trend data and comparisons of sampling results to drinking water EALs to HDOH quarterly.

In groundwater model simulations, an extended light non-aqueous-phase liquid (LNAPL) fuel plume of jet propellant (JP-5 or JP-8) within 1,099 feet of the U.S. Navy well 2254-01 infiltration gallery resulted in benzene concentrations greater than the Federal maximum contaminant level (MCL) of 5 µg/L in the infiltration gallery. It was estimated that a release as small as 16,000 gallons of JP-5 near Tanks 1 or 2 could result in this condition. The groundwater monitoring program provides Site-Specific, Risk-Based Levels (SSRBLs) for total petroleum hydrocarbons (4.5 mg/L) and benzene (0.75 mg/L). These are used as indicators that LNAPL is present. In addition, this Groundwater Protection Plan provides a table of recommended responses to contaminant levels and trends in each of the four wells that are sampled quarterly.

In accordance with this Groundwater Protection Plan, the U.S. Navy will implement a soil vapor monitoring program using the existing boreholes beneath each of the active tanks in the Facility to support leak detection and the groundwater monitoring program. Soil vapor monitoring beneath each tank can provide quick confirmation of potential leaks identified by the automatic system. This will potentially limit the size of a hypothetical fuel release, by shortening the confirmation and response time. Soil vapor will be analyzed for total volatile hydrocarbons (TVH) with calibrated field instruments, and data will be evaluated for changes in concentration which would indicate a release of fuel from the associated tank. Along with confirmation sampling at suspected leaking tanks on an as needed basis, the U.S. Navy will collect soil vapor samples from slant borings beneath each tank quarterly. These data will also be provided to

HDOH quarterly. The U.S. Navy will maintain a complete database of SVMP results to evaluate trends.

The U.S. Navy will continue to conduct a rigorous maintenance schedule for all USTs in the Facility in accordance with the modified American Petroleum Institute (API) 653. The U.S. Navy will provide the results of the API inspections and maintenance reports to HDOH with the quarterly reports associated with groundwater and soil vapor monitoring.

Finally, the Groundwater Protection Plan provides an overview of actions that would be required to remediate the basal drinking water aquifer if a large release of fuel were to migrate to the water table. Well head treatment facilities at the U.S. Navy well 2254-01 may be required to ensure that adequate water is available to meet the U.S. Navy mission at Pearl Harbor. The U.S. Navy estimated \$28,300,000 would be required for a granular activated carbon water purification plant for the U.S. Navy Waiawa well shaft. This system was proposed to remove low levels of agri-chemicals for a system with a maximum pumping capacity of 18 million gallons per day (mgd), and included a testing laboratory (see Appendix E). The U.S. Army estimated costs for an air stripping water purification facility in Schofield Barracks to remove low levels of trichloroethylene for a system with a maximum capacity of 4.3 mgd including capital costs and operations for 30 years at \$3,990,000 (see Appendix E).

Under site conditions, remediation of a large fuel release would be extremely costly and technically difficult, due to the underground nature of the Facility, the steep ridgeline upon which the Facility is located, the distance from ground surface to the aquifer (between 400 and 500 feet on the Red Hill ridgeline), and finally because of the complex hydrogeology associated with the fractured basalt aquifers. Pump and treat methods could be implemented but would be costly and inefficient in this environment. Multi-phased extraction may be more efficient, but very complex at the depths required.

Downgradient enhanced bioremediation was considered through the addition of dissolved oxygen to the groundwater. An array of wells between the Facility and the potable water infiltration gallery would be required as oxygen distribution points to create a reactive permeable barrier to the transmission of dissolved petroleum compounds. Air sparging, while economical, is inefficient in saturating the groundwater to enhance bioremediation. Oxygen release compounds or gas infusion technology could be considered to increase the efficiency of the barrier by increasing the dissolved oxygen content of the groundwater and the radius of influence.

This page intentionally left blank.

1 INTRODUCTION

The Naval Facilities Engineering Command (NAVFAC) Pacific, tasked TEC Inc. (TEC) with the development of this Groundwater Protection Plan to evaluate the impact of inadvertent releases of petroleum, oils and lubricants (POL) from the Fleet and Industrial Supply Center (FISC), Pearl Harbor bulk fuel storage facility located at Red Hill, Oahu, Hawaii (herein referred to as the Facility). This report has been prepared under Contract No. N62742-02-D-1802, Amendment 6, Revision 3 Dated 12 October 2005 for Contract Task Order (CTO) 007.

This plan addresses procedures for evaluating and responding to releases to soil/rock or groundwater that are not an imminent threat but that could cause harm to human health or the environment due to subsequent contamination of various media.

1.1 Description of the Facility

The Facility is located approximately 2.5 miles northeast of Pearl Harbor (Figure 1-1). The Facility lies along the western edge of the Koolau Range and is situated on a topographic ridge that divides the Halawa Valley and the Moanalua Valley. The site is bordered to the south by the Salt Lake volcanic crater, and the Site occupies approximately 144 acres of land. The majority of the surface topography of the Site lies at an elevation of approximately 200 to 500 feet above mean sea level (msl), however, much of the work conducted onsite is in underground tunnels, which are located between 100 to 120 feet msl (Figure 1-2).

The Facility was originally built to support World War II war efforts in the Pacific. Since then the Facility has been instrumental in storing and transporting fuel to support the U.S. Navy's mission throughout the world.

The Facility consists of 20 12.5-million gallon (Mgal) underground storage tanks (USTs) constructed by the U.S. Government in the early 1940s. At the time of this report, 5 tanks (1, 6, 15, 16 and 19) were out of service. The steel tank storage system, constructed in-place, is comprised of two parallel rows of vertical tanks sloping south southeast towards Pearl Harbor and measuring approximately 245 feet in height and 100 feet in diameter. The upper domes of the tanks lie at depths varying between approximately 100 feet and 200 feet below the existing ground surface, and are accessed by interconnected tunnels. The pipelines extend 2.5 miles from the tanks to Pearl Harbor.

The tanks currently contain Jet Propulsion fuel no. 5 (JP-5), Jet Propulsion fuel no. 8 (JP-8) and F-76 (Diesel marine fuel), however they historically contained diesel oil, Navy Special Fuel Oil (NSFO), Navy distillate (ND), F-76, aviation gas (AVGAS), motor gas (MOGAS), JP-5 and JP-8. Originally, Tanks 3 through 20 contained NSFO and Tanks 1 and 2 contained diesel oil. Over time, all tanks have been used to store a variety of fuel (TEC, 2005).

1.2 Description of the Problem

The potential impact of an inadvertent fuel release to the groundwater system is the main risk driver for the Facility. The Facility is approximately 100 feet above the basal groundwater table on the boundary of the Waimalu and Moanalua Aquifer Systems of the Pearl Harbor and Honolulu Aquifer Sectors, respectively. Both aquifers are sources of potable water for several public water systems. The Moanalua Aquifer and Waimalu Aquifer systems are classified by Mink and Lau as unconfined, basal, and flank (Figure 1-3). Their status is listed as currently used, fresh (chloride content below 250 milligrams per liter [mg/L]) drinking water sources that are irreplaceable and has a high vulnerability to contamination (Mink and Lau 1990). The nature of the fractured basalt beneath the site would make cleanup of a future petroleum release difficult.

There are several potable water supply wells in the vicinity of the Facility (Figure 1-4). The impact of a large release would be very costly and would jeopardize Navy mission by potential loss of the potable water supplied by U.S. Navy well 2254-01. The U.S. Navy well 2254-01 is located approximately 3,000 feet west and hydraulically downgradient from the USTs at the Facility. According to the Commission on Water Resources data for 1989-2005, on average approximately 4.4 million gallons per day (mgd) are withdrawn from this location. This well supplies approximately 24 percent of the total Pearl Harbor Water System (PHWS), which serves approximately 52,200 military consumers on Oahu. The Honolulu Board of Water Supply (HBWS) Halawa Shaft well 2354-01 is located approximately 5,000 feet northwest of the Facility. On average, 11.8 mgd of potable water is withdrawn from this location, approximately 12 percent of the total supply that serves 607,542 people on Oahu. In addition, the HBWS Moanalua wells (2153-10, 2153-11, 2153-12) lay approximately 6,700 feet south of the Facility (Figure 1-3) and deliver potable water to the HBWS.

Due to the previously classified status of Facility, public access and independent investigations were not conducted prior to 1995. However, records indicate that one or more tanks may have leaked and were repaired. A maintenance program is currently evaluating the condition of specific tanks (TEC, 2005). Previous investigations (Ogden, 1995; AMEC, 2002; TEC, 2007) indicated that past inadvertent releases of POL have reached the basal aquifer. Based on the results of these investigations, the State of Hawaii Department of Health (HDOH), Solid Waste Branch, UST Division recommended in a letter dated October 10, 2003 that the U.S. Navy develop a contingency plan “to protect the Navy’s Halawa Adit No. 3 Drinking Water Pumping Station” (U.S. Navy well 2254-01). Although the Facility is addressed in the Navy Region Hawaii Integrated Contingency Plan (ICP), The Water Systems Emergency Response Plan (Earth Tech, 2005), and the Spill Prevention and Countermeasure (SPCC) Plan for COMNAVREG Hawaii (Hawaii Pacific Engineers, 2006), none of these plans addressed response actions to releases of POL to soil/rock or groundwater that could potentially threaten this drinking water supply (United States Environmental Protection Agency [USEPA] Safe Drinking Water Act [SWDA]). In addition, HDOH requested documentation of any structural

integrity or other engineering investigations that documented the condition of the Facility UST system as provided in the modified American Petroleum Institute (API) 653 and presented in Section 3.1.1, Tank Maintenance and Repair History. HDOH also recommended installation of a leak detection system for the USTs. These elements are all addressed in this Groundwater Protection Plan.

1.3 Groundwater Protection Plan Scope and Objectives

This Groundwater Protection Plan is the culmination of a comprehensive environmental site investigation (SI) to evaluate the impact of past releases of POL from the Facility. The SI included the construction of a network of groundwater monitoring wells to evaluate the impact of fuel on the basal aquifer (Figure 1-4), development of a three-dimensional (3-D) groundwater flow and contaminant transport model, and evaluation the risk to nearby drinking water wells from mobile petroleum contaminants using a Tier 3 risk assessment. The conceptual site model (CSM) and risk assessment indicated that the Facility was geologically isolated from the ground surface and that the only migration pathway of significant concern resulting from non-catastrophic releases was via groundwater to drinking water wells.

This Groundwater Protection Plan is intended to document the steps that are being taken or are planned for future implementation to prevent unacceptable risks associated with use of the groundwater potentially impacted by releases from the Facility to human health and the environment.

These steps will include the following:

- Implementation of a tank inspection and maintenance program.
- Description of vapor monitoring results.
- Description of groundwater sampling and risk assessment.
- Implementation of a consistent, documented groundwater monitoring program that will provide adequate warning of any potential unacceptable risks to human health.
- Establishment of a decision system, including responsibilities and specific response actions that will be implemented when risk-based groundwater action levels are exceeded.
- Implementation of a market survey to evaluate best available leak detection technologies available for large field constructed fuel storage facilities, such as Red Hill.

These steps are in accordance with the Hawaii Environmental Response Law (HERL), UST Program, and State Contingency Plan (SCP). These steps are intended to protect human health and the environment from non-catastrophic past, present and future releases of POL which are chronic in nature, defined as on the scale of 10 gallons per minute or less. Due to the nature of the Facility, releases of this size are very difficult to detect, but over time may cause severe damage to the groundwater resource and negatively impact the mission of the U.S. Navy. These

steps are not intended to address risks associated with a catastrophic release of fuel to the environment resulting from a large rupture in the steel tanks or piping system. These catastrophic events would require emergency response actions that are not within the scope of this document.

1.4 Groundwater Protection Plan Updates

This groundwater protection plan will be reviewed every five years after the date of approval by HDOH to determine if it needs to be updated to meet the objectives stated above. Either the document will be updated or it will be documented that no update is required. In either situation, the decision or update shall be submitted to HDOH for approval.

1.5 Navy Region Hawaii Integrated Contingency Plan

The Navy Region Hawaii ICP addresses potential catastrophic releases from the Pearl Harbor Fuel Storage Facilities that have the potential to impact navigable waters. This plan does not seek to protect groundwater resources that can be used for human consumption or for irrigation purposes. The ICP specifies the use of the National Incident Management System Incident Command System (ICS) during the response to address catastrophic oil and hazardous substances (OHS) releases from the Facility that have the potential to impact navigable water.

The Commander, Navy Region Hawaii (COMNAVREG HI) ICS organization is utilized when responding to large spills or emergency release incidents posing a substantial threat to the public or the environment at the Facility. COMNAVREG HI, as the Navy On-Scene Coordinator (NOSC), is responsible for directing and/or coordinating responses to OHS releases when it is beyond the spiller's capability. The Facility Incident Commander (FIC) will direct the response efforts of the Facility Release Response Management Team for releases at the Facility. If the response is beyond this team's capability, the NOSC will be notified and the Facilities Release Response Management Team will become part of the NOSC ICS organization. The FIC can activate personnel as required depending on the incident size and complexity.

1.6 Water System Emergency Response Plan

The Water System Emergency Response Plan was developed as part of the USEPA SWDA to respond to terroristic attacks. It provides an independent set of procedures for the PHWS to respond in the event of natural or man-made emergencies impacting this potable water system (Earth Tech, 2005). This plan provides procedures to mitigate the risk of exposure to contaminated water within the storage and transport facilities of the PHWS, but does not address procedures to mitigate risk associated with contamination within the groundwater resource.

1.7 Conceptual Site Model and Risk

This Section describes the results of recent studies completed at the Facility (TEC, 2007). The subsections below include site-specific descriptions of the source, CSM, exposure pathways and receptors, contaminant fate and transport using groundwater modeling, and risk assessment.

1.7.1 Description of the Facility

The potential source of contamination at the Facility are the 20 12.5-Mgal USTs and associated buried piping that hold petroleum products. The Facility began operating in 1943 and has the capacity to hold approximately 250 million gallons of fuel. It currently contains JP-5, JP-8, and F-76. The tank storage system is comprised of two parallel rows of vertical tanks sloping south southeast towards Pearl Harbor. The tanks are installed into native basalt, each measuring 245 feet in height and 100 feet in diameter. They are located approximately 100 to 200 feet below ground surface (bgs), and are accessed by interconnected tunnels. The fuel pipelines extend 2.5 miles within the tunnels to Pearl Harbor. The Facility is located between Moanalua Valley to the southeast and the North Halawa Valley to the northwest. These valley fills dip beneath the basal water table in the vicinity of the Facility. According to MODPATH simulations using the 3-D groundwater model developed for the Facility, the valley fills present semi-permeable barriers to the lateral migration of groundwater. For the purposes of this report, the groundwater sub-basin between these two valley fills will be called the Red Hill sub-basin. In addition, these simulations indicate that these valley fills are protective of the HBWS Halawa Shaft (2354-01) and HBWS Moanalua wells (2153-10, -11, and -12). The ten-year capture zones of these wells are contained by the valley fill barriers.

According to the *Aquifer Identification and Classification for Oahu: Groundwater Protection Strategy For Hawaii* (Mink and Lau, 1990), produced to support the HDOH groundwater protection program, the Red Hill ridgeline makes up the boundary between the Waimalu System of the Pearl Harbor Aquifer Sector and the Moanalua System of the Honolulu Aquifer Sector. No known groundwater divide exists along this geomorphic boundary and groundwater is believed to flow freely between these two aquifer designations at this boundary. As indicated in the previous paragraph, a more realistic geomorphic boundary for these two aquifers is the North Halawa Valley fill, which dips below the basal water table in upper North Halawa Valley and is estimated to be between 300 and 400 feet below msl at the base of Halawa Valley (Oki, 2005).

According to Mink and Lau (1990), both the Waimalu and Moanalua Systems are basal, unconfined, in flank lavas, and are currently used, drinking water sources, fresh, irreplaceable, and highly vulnerable to contamination.

The tanks in the Facility have historically contained diesel oil, NSFO, ND, F-76, AVGAS, MOGAS, JP-5 and JP-8. Originally, Tanks 3 through 20 contained NSFO, and Tanks 1 and 2 contained diesel oil. Over time, all tanks have been used to store a variety of fuel (TEC, 2005a). Due to the previously classified status of the Facility, public access and independent investigations of the Facility were previously not conducted. However, some records indicate that the tanks may have leaked and were repaired (TEC, 2005a; see Section 3).

The pipelines associated with the Facility tanks run along tunnels where they can be inspected, except for pipelines immediately adjacent to the tanks, which are underground. Records do not indicate any major releases occurred from the external pipelines that could be a source of contamination reaching basal groundwater.

1.7.2 Nature and Extent of Contamination

1.7.2.1 Rock Boring Sample Results

A slant borehole was advanced at an angle of 10- to 15-degrees from the floor of the lower tunnel directly adjacent to each of the USTs in the Facility, to a distance of approximately 125 feet from the point of entry (POE). These boreholes run from the inside edge to the outside edge, and approximately 10 to 20 feet below each UST. Petroleum contamination was evident in several of the cores, particularly beneath Tanks 1, 6, 14, and 16 based on testing of the rock. (AMEC Earth and Environmental, Inc. [AMEC], 2002). The most likely source of the petroleum contamination was from the USTs, although it is possible that the leaks could have originated from buried piping or spills in the tunnels that seeped into the rock. Core samples collected during subsequent drilling activities to install monitoring wells RHMW02 and RHMW03 within the Facility lower access tunnel showed no evidence of petroleum in the unsaturated rock at these locations.

1.7.2.2 Groundwater Sample Results

The first SI groundwater sampling event was conducted in September of 2005 from the three wells within the Facility, the background well and the U.S. Navy well 2254-01. Total Petroleum Hydrocarbons in the Diesel Range Organics (TPH-DRO) exceeded State of Hawaii Environmental Action Levels (EALs) for drinking water at all wells except U.S. Navy well 2254-01. No evidence of petroleum was observed at U.S. Navy well 2254-01.

Groundwater from RHMW02, located upgradient from Tanks 5 and 6, had the highest concentrations of petroleum compounds. RHMW02 was the only well in which target Volatile Organic Compounds (VOCs) and Semi-Volatile Organic Compounds (SVOCs) were observed. Concentrations of TPH-DRO, Total Petroleum Hydrocarbons in the Gasoline Range Organics (TPH-GRO), trichloroethylene (TCE), naphthalene, 1-methylnaphthalene and 2-methylnaphthalene all exceeded one or more drinking water action levels (EALs or USEPA Region 9 Preliminary Remediation Goals [PRGs]) in this well.

Lead exceeded drinking water action levels in unfiltered samples, though filtered samples did not. According to the HDOH (March 2000) groundwater action levels for inorganics are based on dissolved constituents, therefore unfiltered sample results are not appropriate for comparison.

The second SI groundwater sampling event was conducted in July 2006. Results were similar, except TCE was not observed.

1.7.2.3 Soil Vapor Sample Results

As part of the SI, a soil vapor pilot study was conducted in which soil vapor monitoring points (SVMPs) were constructed within the slant borings beneath seven of the 12.5-Mgal USTs. Although results from the first SVMP sampling events indicated soil gas concentrations were less than HDOH EALs protective of worker health at the Facility, the range in concentrations and chemicals detected indicated:

1. Soil vapor beneath the USTs contains petroleum-related compounds;
2. SVMPs could be used to sample for these volatile chemicals;
3. SVMPs sample results identified potential release areas beneath the USTs where petroleum concentrations in soil gas were elevated, compared to concentrations indicative of ambient conditions beneath the USTs.

Based on these results, the SVMPs with the highest soil vapor readings are beneath Tanks 6, 16, 14, 11, and 12. Soil vapor results are shown in Table 1-1.

Table 1-1. Total Soil Vapor

Sample	Soil Vapor Total (ppbV)	Ranking based on ppbV	Soil Vapor Total ($\mu\text{g}/\text{m}^3$)	Ranking based on $\mu\text{g}/\text{m}^3$
RHSV02-15-40	17	11	42	11
RHSV02-46-73	43	7	129	7
RHSV02-79-110	20	10	39	12
RHSV06-15-35	127	2	557	1
RHSV06-40-56	7	15	29	13
RHSV10-13-30	6	16	22	15
RHSV10-40-130	8	14	22	16
RHSV11-13-30	14	12	66	10
RHSV11-40-131	63	4	257	4
RHSV12-15-40	50	6	206	5
RHSV12-46-68	2	17	9	17
RHSV12-76-133	10	13	27	14
RHSV14-15-40	2	18	5	18
RHSV14-46-73	117	3	438	3
RHSV14-79-110	52	5	152	6
RHSV16-15-40	175	1	452	2
RHSV16-46-73	26	8	69	9
RHSV16-79-110	23	9	72	8

1.7.3 Comprehensive Conceptual Site Model

A CSM was developed for the Facility in accordance with the USEPA's Risk Assessment Guidance for Superfund (USEPA, 1988, 1991). A graphic representation of the CSM is shown in

Figure 1-5. The CSM provides a framework for evaluating sources, potential exposure pathways, and receptors.

The current CSM is based on the recent investigation of the Facility (TEC, 2007). The CSM illustrates the migration pathways of potential concern for this Groundwater Protection Plan. Potential receptors include persons utilizing the basal groundwater. Migration pathways are described below:

- Vertical movement through basalt to basal groundwater;
- Movement in basal groundwater to downgradient potable water wells; and
- Expected isolation of the Red Hill groundwater basin from HBWS wells (Halawa Shaft well 2354-01 and Moanalua wells 2153-10, -11, and -12) due to the depth of the North Halawa Valley and Moanalua Valley fills.

1.7.3.1 Groundwater Usage

The Facility is located up-gradient of the Hawaii State Underground Injection Control Line (UIC), which separates potable from non-potable groundwater. The nearest public drinking water well (HBWS Halawa Shaft well 2354-01) is located hydraulically cross-gradient of the site. This drinking water well is approximately 5,000 feet to the northwest of the Facility and pumps water from the basal aquifer. On average, 11.8 mgd are withdrawn from this location. This well is part of a water system that serves 607,542 people on Oahu and this particular well supplies approximately 12% of the water to that system.

The U.S. Navy well 2254-01 is located near the site. This well is approximately 3,000 feet to the west of the site and is potentially down-gradient from the Facility. Between 4.4 and 16 mgd are withdrawn from this location. The U.S. Navy well 2254-01 currently provides approximately 24 percent of the potable water to the PHWS, which serves approximately 52,200 military consumers.

1.7.3.2 Contaminant Fate and Transport and Groundwater Modeling

TEC, the University of Hawaii at Manoa (UH) and NAVFAC Hawaii collaborated on development of a local 3-D finite difference model based on an existing MODFLOW regional groundwater model developed by the UH for HDOH Safe Drinking Water Branch (SDWB) Source Water Assessment Program (SWAP). The localized model focused on modeling the contacts for local valley fills in the saturated zone because several important municipal water supply wells lie within a mile of the Facility, but on opposite sides of these low-flow barriers from the Facility. Once the model was developed, a pumping test was performed using the U.S. Navy well 2254-01 as the drawdown well, and monitoring points north of the Halawa Valley fill, south of the Moanalua Valley fill, and within the Red Hill ridge zone (unaffected by valley fills). The pumping test results were simulated using the 3-D flow model to calibrate the transient state of the model with reasonable precision.

Contaminant transport simulations were conducted using MODPATH to evaluate conservative particle transport, and RT3D (Clement, 1997), a high level transport model that accounts for all major transport processes, including advection, diffusion, dispersion, decay and sorption. The objective was to estimate the dissolved concentrations at the Facility monitoring wells that would result in exceedences at the nearby municipal water supply wells. Simulations were run under an average pumping scenario, in which area supply wells were pumped at average pumping rates for the period of 1996 to 2005. In addition, once the critical concentrations within the Facility were estimated, a drought condition was simulated in which the U.S. Navy well 2254-01 was pumped at maximum rates to determine the worst case scenario, and sensitivity of the system to pumping conditions.

An important factor in evaluating the risk of a fuel release from the Facility is the type of fuel that is stored in the USTs. Although AVGAS and MOGAS were stored at the Facility between 1964 and 1969 in two tanks, since then, JP-5 and JP-8 have been the on-site fuels with the most potential to impact human health and the environment. JP-5 and JP-8 are jet propellants, similar to kerosene, with a total solubility of about 4.5 mg/L, very low concentrations of benzene, toluene, ethylbenzene, and xylenes (BTEX), and an effective solubility of benzene of approximately 0.75 mg/L. Although polynuclear aromatic hydrocarbons (PAHs) make up a small component of jet fuels, they are significantly less mobile than BTEX and not risk drivers for migration in the dissolved phase for this reason. Naphthalene, a mobile PAH common in JP-5, has an effective solubility of 0.25 mg/L, much less than TPH and benzene. Other fuels stored are diesel and less soluble NSFO types.

The results of the modeling, using TPH and benzene as the surrogate risk drivers showed that:

- Simulation of maximum concentrations in infiltrating groundwater through a contaminated vadose zone did not present a risk at adjacent drinking water wells;
 - Valley fills represented by North Halawa Valley and Moanalua Valley are effective barriers to particle migration from the Facility to HBWS wells that lie outside these valley fills (HBWS Halawa Shaft, and HBWS Moanalua wells);
 - Simulations in which fuel as light non-aqueous phase liquid (LNAPL) extended downgradient of monitoring well (RHMW01) showed concentrations that exceeded action levels at the infiltration gallery for U.S. Navy well 2254-01;
 - Site-Specific, Risk Based Levels (SSRBLs) at RHMW01, RHMW02 and RHMW03 coincide with solubility limits of JP-5, where benzene is 0.75 mg/L and TPH is 4.5 mg/L; and
 - Groundwater action levels at the U.S. Navy well 2254-01 are the HDOH drinking water EALs.
-

1.7.3.3 Risk Summary

Current and future ecological risk is considered negligible because the Facility is underground and the migration pathway to ground surface or surface water via seeps is not complete.

The human health risk assessment was conducted assuming that future storage will remain JP-5 (kerosene) and heavier fuel mixtures. If lighter fuels, such as AVGAS or MOGAS were to be stored at the Facility in the future, risks due to volatilization would need to be reconsidered. Under the JP-5 and heavier assumption, the following determinations were made:

- The current and future risk of exposure via migration from soil gas to indoor air is considered negligible.
 - The primary environmental risks at the Facility were determined to be due to a future scenario in which groundwater from beneath the site was extracted for residential tapwater use, including drinking. Currently, no extraction wells lie in the vicinity of the current groundwater plume.
 - In addition, if a future release produced a large secondary source of LNAPL on the water table, dissolved contaminants or free-product may result in unacceptable concentrations of petroleum in the Red Hill sub-basin, which feeds into the U.S. Navy well 2254-01 potable water system, decreasing the amount of potable water available to PHWS consumers by 4.5 to 16 mgd.
-

\\Projects\Red Hill\Figures\Figure 1-1 Regional Location Map - 4/16/2007

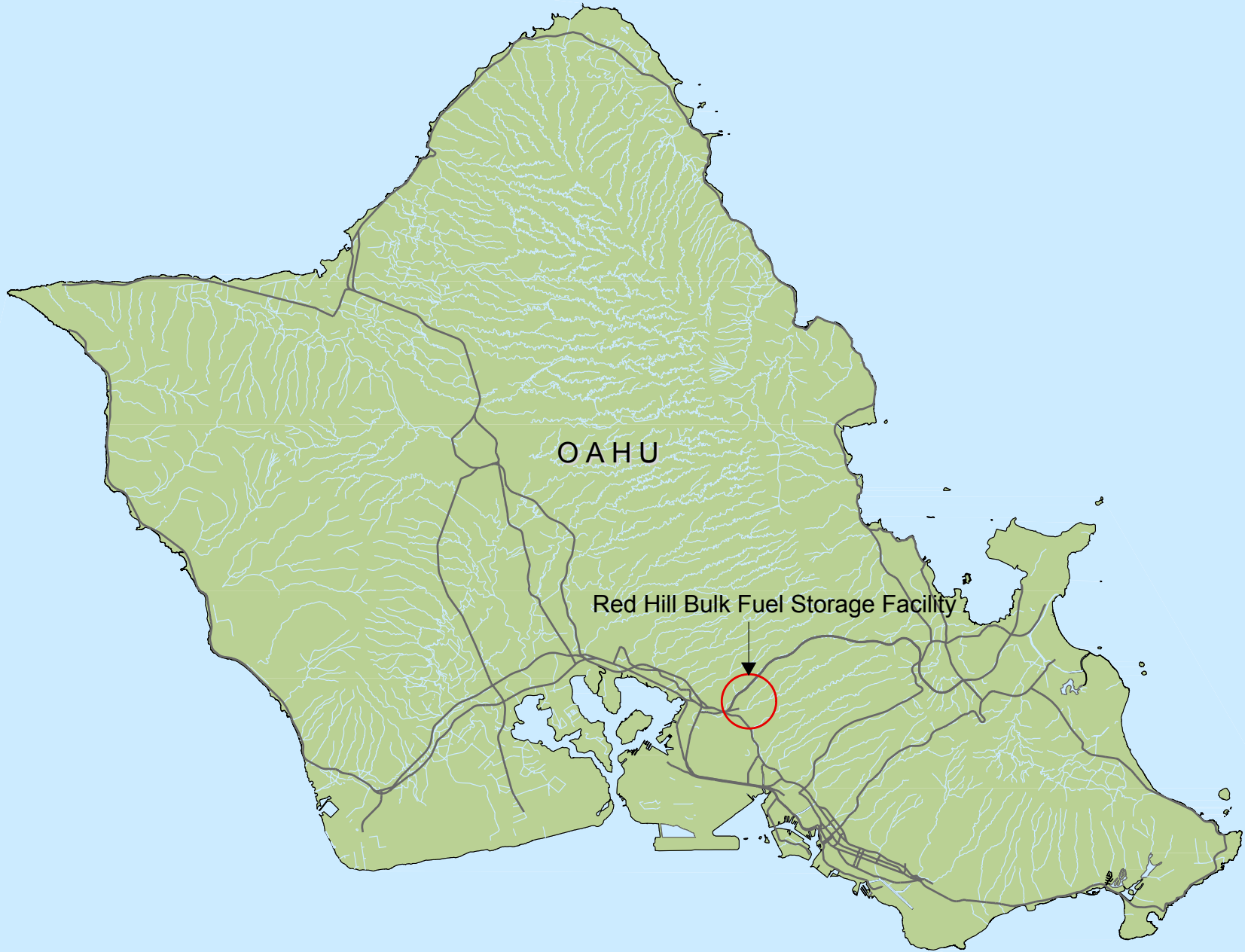
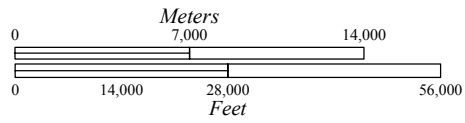
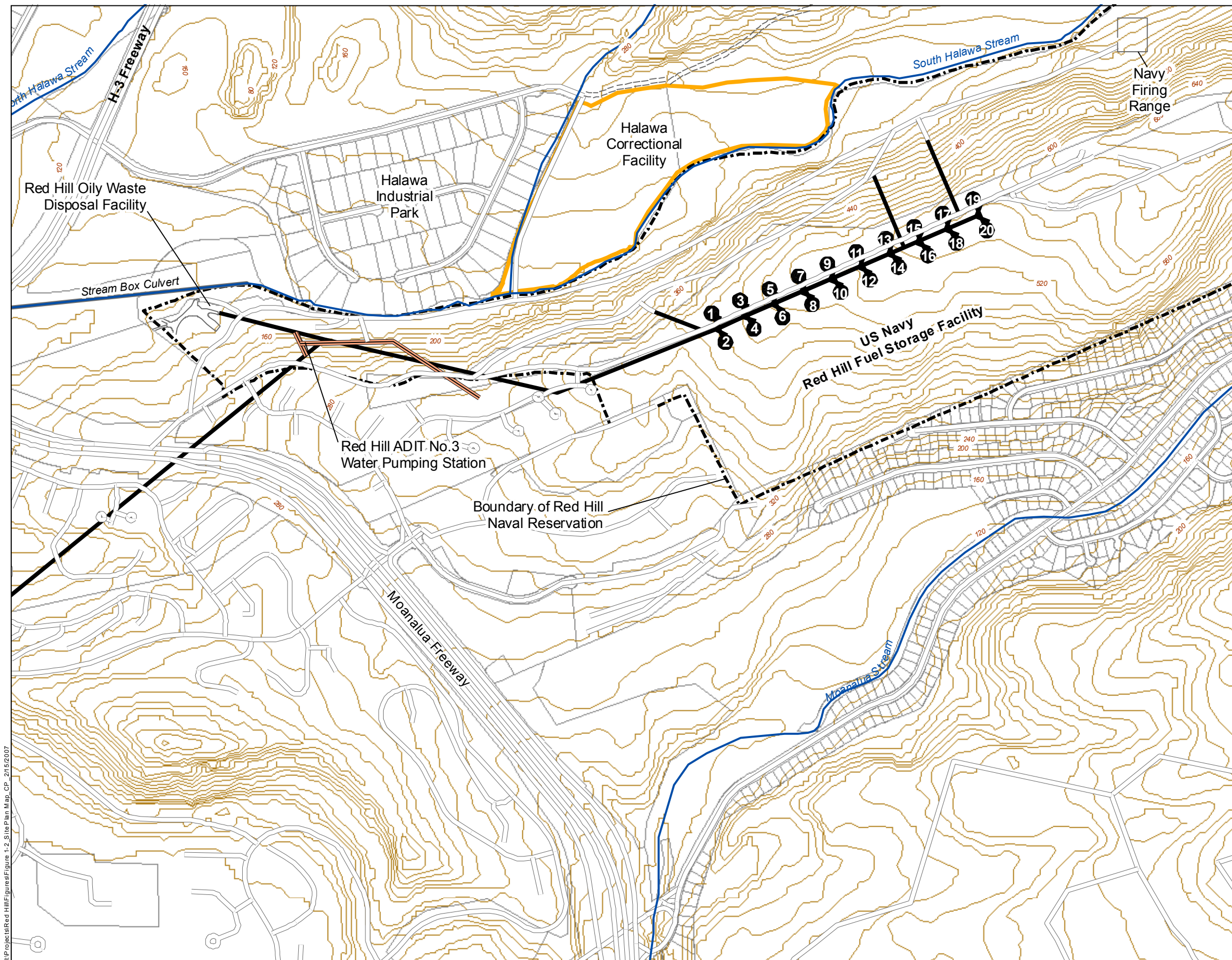

Figure 1-1
Regional Location Map
Red Hill Contingency Plan
Oahu, Hawaii





Legend	
	Red Hill UST ID Number
	Parcel
	40-foot Interval Contour Line
	Unpaved Road
	Road
	Stream
	Red Hill Navy Installation Boundary
	Red Hill Tunnels
	2254-01 Infiltration Gallery
	Halawa Correctional Facility Boundary

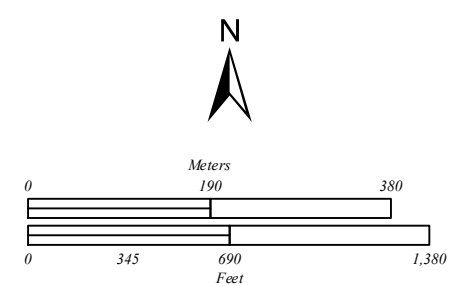
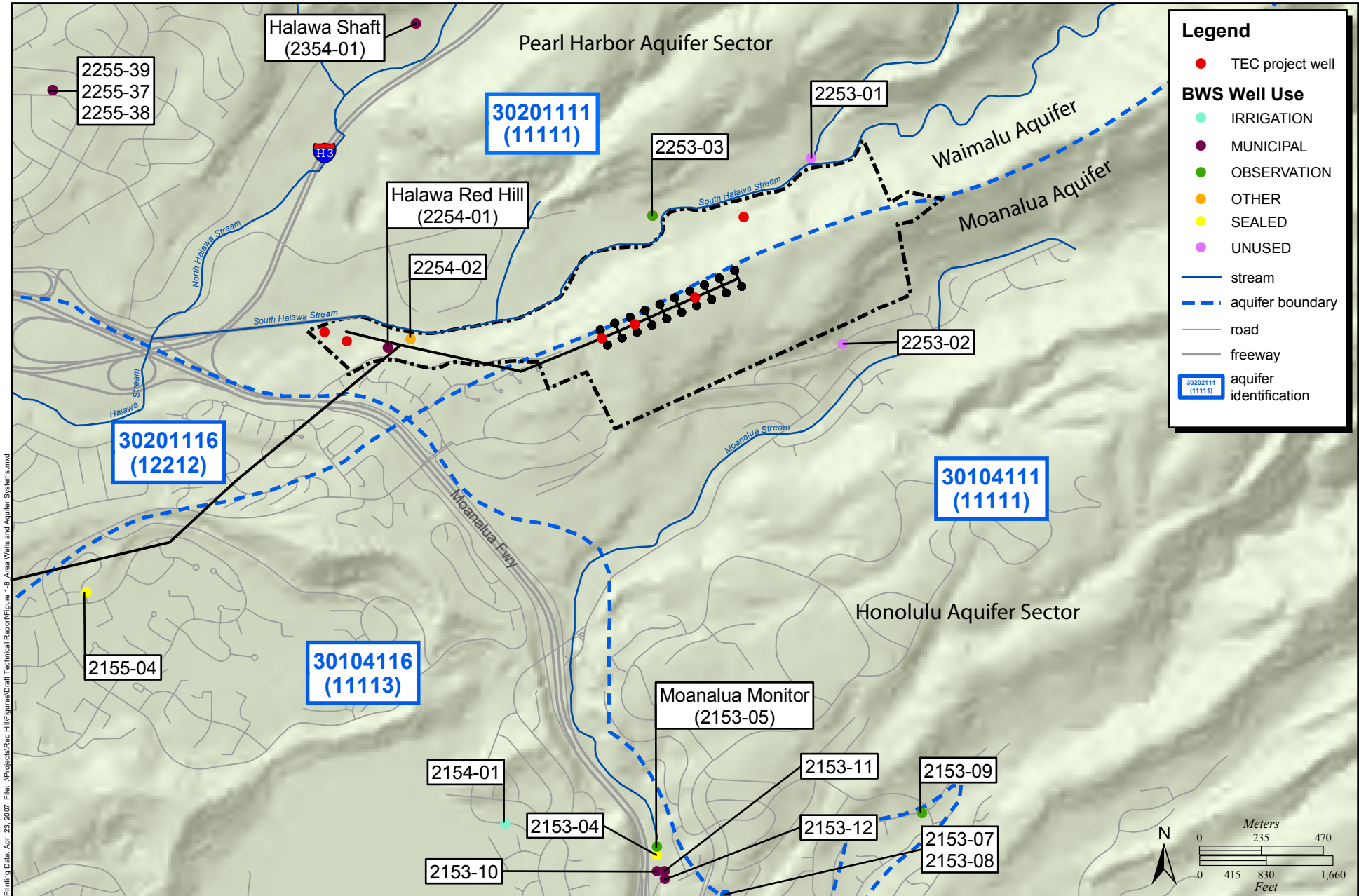

Figure 1-2

Site Plan Map
 Red Hill Fuel Storage Facility
 Oahu, Hawaii

U:\Projects\Red Hill\Figures\Figure 1-2_Site Plan Map_CP_2/15/2007



Printing Date: Apr. 23, 2007, File: \\Projects\Red Hill\Figures\Draft Technical Report\Figure 1-3 Area Wells and Aquifer Systems.mxd

Figure 1-3
Area Wells and Aquifer Systems
 Red Hill Contingency Plan
 Oahu, Hawaii

Source Data:
 City & County of Honolulu,
 GIS base layers
 DLNR Board of Water Supply,
 2005 water supply well IDs



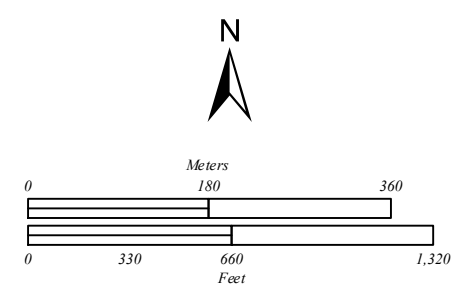
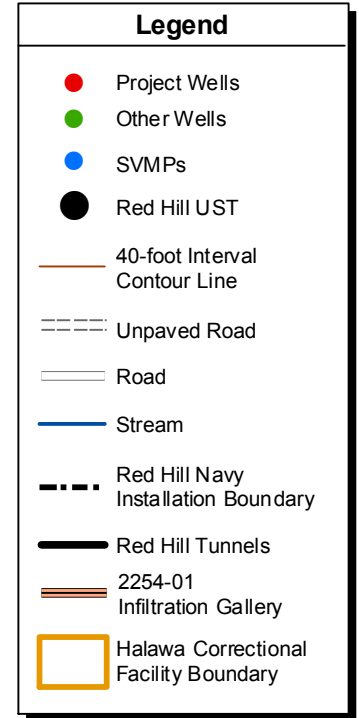
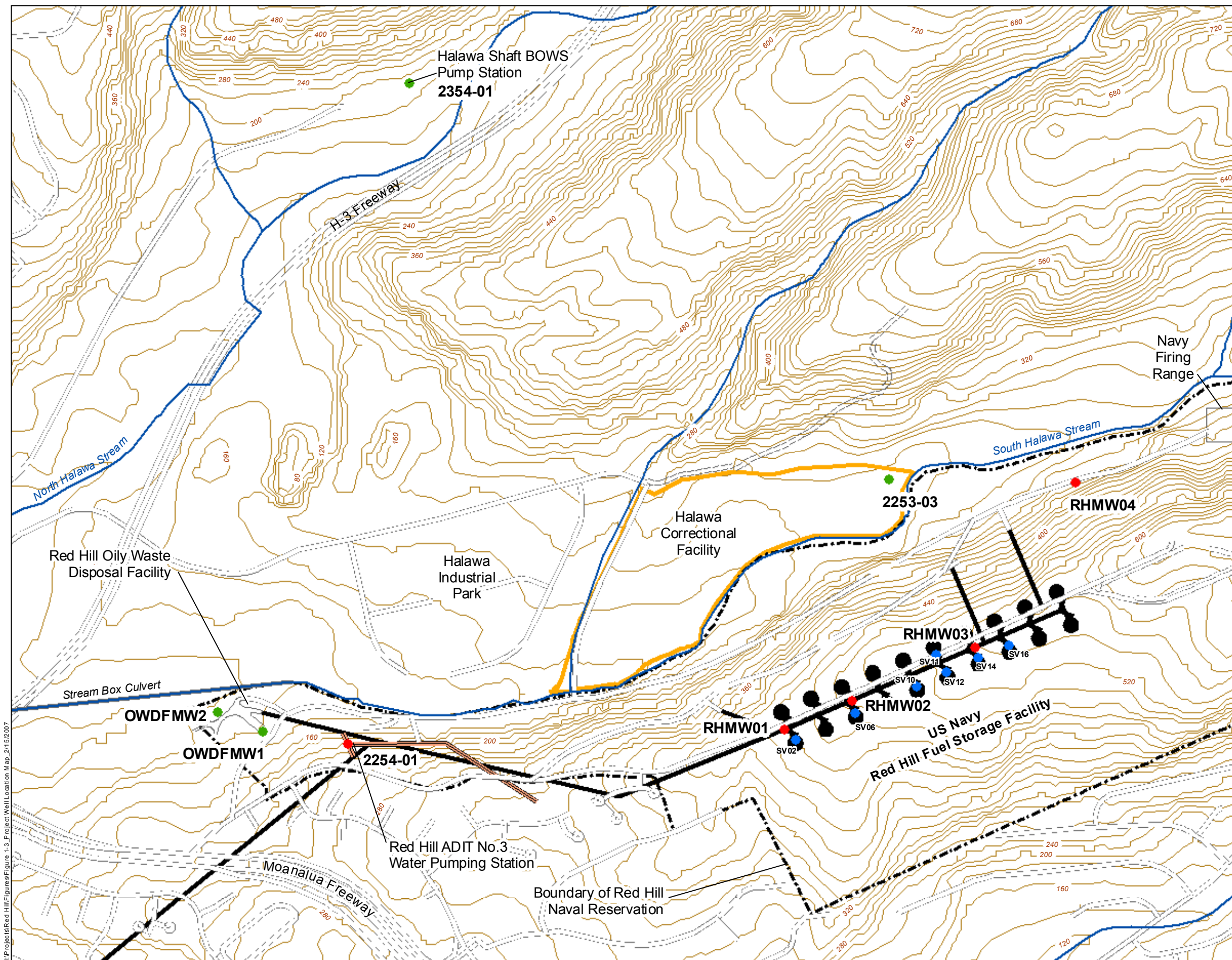

U:\Projects\Red Hill\Figures\Figure 1-3 Project Well Location Map_2/15/2007

Figure 1-4

Project Well Location Map
 Red Hill Contingency Plan
 Oahu, Hawaii

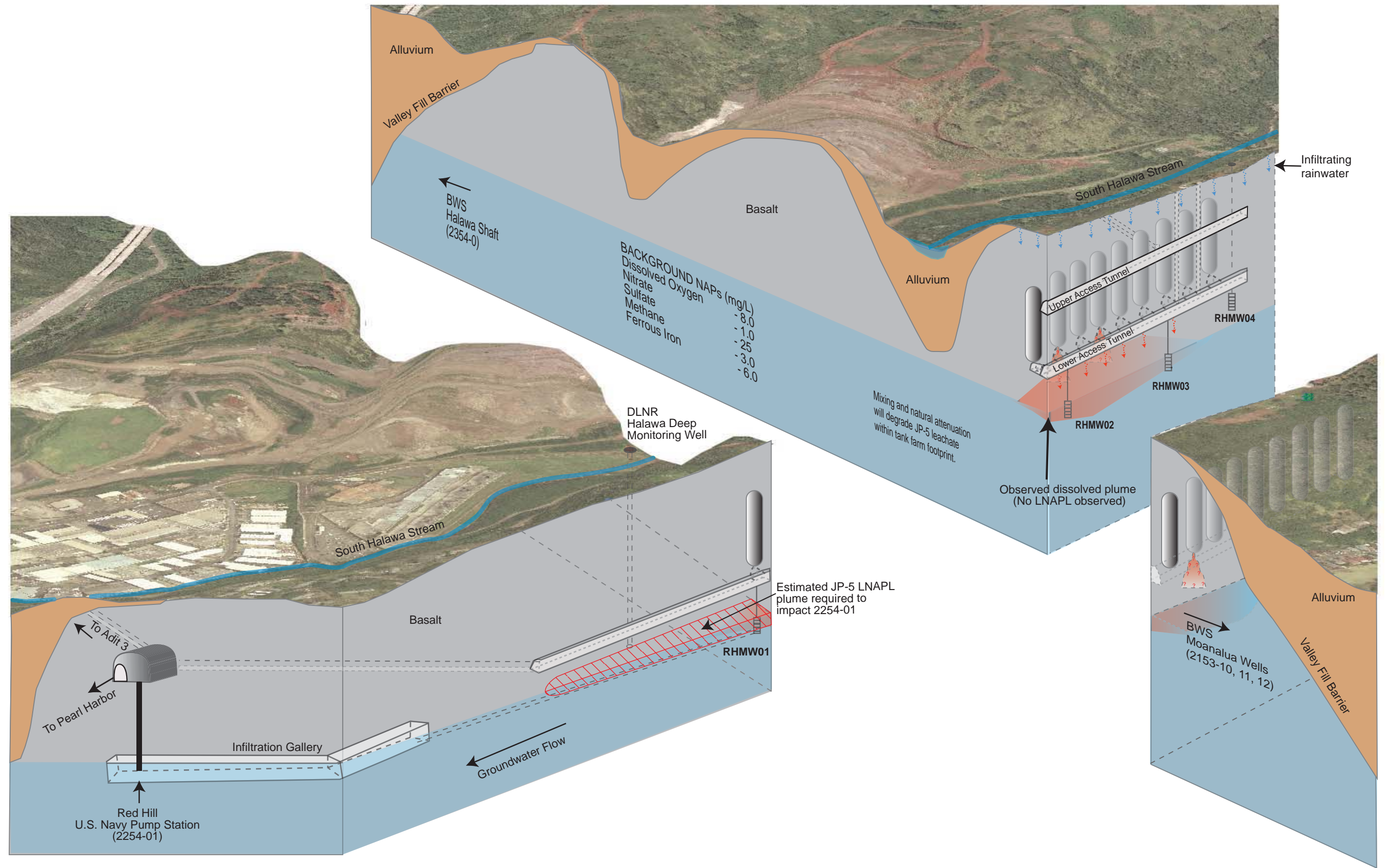

Figure 1-5
Conceptual Site Model
 Red Hill Contingency Plan
 Oahu, Hawaii

This page intentionally left blank.

2 APPLICABLE REGULATIONS AND GUIDANCE

Based on the current knowledge of the Facility and the CSM provided in Section 1, the Federal and state regulatory requirements and guidelines that apply to the Facility include those relating to drinking water and potable water systems; environmental response and contingency plans; and USTs. They are described in the paragraphs below.

2.1 Federal Regulations and Guidance

2.1.1 Drinking Water and Potable Water Systems

The National Primary Drinking Water (NPDW) regulations at 40 Code of Federal Regulations (CFR) Part 141 carries out provisions of the USEPA SDWA. They establish maximum contaminant levels (MCLs) for various substances in potable water.

2.1.2 USTs

The Resource Conservation and Recovery Act (RCRA), established in 1979 and amended with the Hazardous and Solid Waste Amendments of 1984, established a comprehensive regulatory program for USTs.

Most of the regulations concerning USTs are contained in 40 CFR Part 280 and 40 CFR Part 281, although codification of individual state and territorial programs is found in 40 CFR Parts 282.50-282.105. The list of hazardous substances is in 40 CFR Part 302.4.

2.1.2.1 Regulations Applicable to the Facility

Regulations for USTs are found at 40 CFR PART 280—TECHNICAL STANDARDS AND CORRECTIVE ACTION REQUIREMENTS FOR OWNERS AND OPERATORS OF UNDERGROUND STORAGE TANKS (UST). Part 280 contains numerous subparts. Part 280.10(c)(5) states that parts B, C, D, E, and G are deferred and do not apply to UST systems with field-constructed tanks (which is the case for the Facility). The complete list of subparts is listed below with those applicable to the Facility underlined:

- Subpart A - 280.10-280.12 - "Program Scope and Interim Prohibition"
 - Subpart B - 280.20-280.22 - "UST Systems: Design, Construction, Installation and Notification"
 - Subpart C - 280.30-280.34 - "General Operating Requirements"
 - Subpart D - 280.40-280.45 - "Release Detection"
 - Subpart E - 280.50-280.53 - "Release Reporting, Investigation, and Confirmation"
 - Subpart F - 280.60-280.67 - "Release Response and Corrective Action for UST Systems Containing Petroleum or Hazardous Substances"
 - Subpart G - 280.70-280.74 - "Out-of-Service UST Systems and Closure"
-

- Subpart H - 280.90-280.116 - "Financial Responsibility"
- Subpart I - 280.200-280.230 - "Lender Liability"

Subpart F does apply; sections in this subpart are:

- § 280.61 Initial response.
- § 280.62 Initial abatement measures and site check.
- § 280.63 Initial site characterization.
- § 280.64 Free product removal.
- § 280.65 Investigations for soil and ground-water cleanup.
- § 280.66 Corrective action plan (CAP).
- 280.67 Public participation. (required only if a CAP is required)

The CAP section § 280.66(a) states “At any point after reviewing the information submitted in compliance with §§ 280.61 through 280.63, the implementing agency may require owners and operators to submit additional information or to develop and submit a corrective action plan for responding to contaminated soils and ground water. If a plan is required, owners and operators must submit the plan according to a schedule and format established by the implementing agency.”

2.1.2.2 Regulations “To Be Considered” at the Facility

Certain regulations do not apply specifically to the Facility, but do have performance criteria that were considered in the preparation of this Groundwater Protection Plan. These parts are described below.

Subpart D (Release Detection) § 280.40 General requirements for all UST systems

- (a) Owners and operators of new and existing UST systems must provide a method, or combination of methods, for release detection that:
- (1) Can detect a release from any portion of the tank and the connected underground piping that routinely contains product;
 - (2) Is installed, calibrated, operated, and maintained in accordance with the manufacturer’s instructions, including routine maintenance and service checks for operability or running condition; and
 - (3) Meets the performance requirements in § 280.43 or 280.44, with any performance claims and their manner of determination described in writing by the equipment manufacturer or installer. In addition, methods used after the date shown in the following table corresponding with the specified method except for methods permanently installed prior to that date, must be capable of detecting the leak rate or quantity specified for that
-

method in the corresponding section of the rule (also shown in the table) with a probability of detection (PD) of 0.95 and a probability of false alarm (Pfa) of 0.05.

Subpart D (Release Detection) § 280.43 Methods of release detection for tanks

- (a) Inventory control. Product inventory control (or another test of equivalent performance) must be conducted monthly to detect a release of at least 1.0 percent of flow-through plus 130 gallons on a monthly basis in the following manner.
- (d) Automatic tank gauging (ATG). Equipment for automatic tank gauging that tests for the loss of product and conducts inventory control must meet the following requirements:
 - (1) The automatic product level monitor test can detect a 0.2 gallon per hour leak rate from any portion of the tank that routinely contains product; and
 - (2) Inventory control (or another test of equivalent performance) is conducted in accordance with the requirements of § 280.43.
- (h) Other methods. Any other type of release detection method, or combination of methods, can be used if:
 - (1) It can detect a 0.2 gallon per hour leak rate or a release of 150 gallons within a month with a probability of detection (PD) of 0.95 and a probability of false alarm (PFA) of 0.05; or
 - (2) The implementing agency may approve another method if the owner and operator can demonstrate that the method can detect a release as effectively as any of the methods allowed in paragraphs (c) through (h) of this section. In comparing methods, the implementing agency shall consider the size.

2.2 Hawaii Regulations and Guidance

2.2.1 Drinking Water and Potable Water System Regulations

The HDOH Rules Relating to Hawaii Potable Water Systems (HPWS) (Hawaii Administrative Rules [HAR] Title 11, Chapter 20) set forth MCLs of certain chemicals in public and private drinking water systems. These MCLs are analogous to the NPDW regulations but additional substances are regulated.

2.2.2 Hawaii Environmental Response Law and State Contingency Plan Regulations

The Hawaii Revised Statutes Title 19, Chapter 128D and SCP (HAR Title 11, Chapter 451) is intended to identify releases and other situations that may endanger public health or welfare, the environment, or natural resources; prescribe notification requirements; and establish methods to address such releases. The SCP is intended to address contaminants and releases not addressed by other State of Hawaii Laws and Rules. It establishes reportable quantities for hazardous substances, pollutants, and contaminants for release purposes. The HERL definition of a hazardous substance includes petroleum. Methods and criteria for investigations and response actions conducted under the SCP are described in the technical guidance manual (TGM) for the

Implementation of the Hawaii State Contingency Plan (HDOH, 1997). The TGM indicates that the following four criteria should be evaluated to determine whether further action is necessary for a site:

1. There has been no release of a hazardous substance, pollutant, or contaminant to the environment.
2. There is no threat of release of a hazardous substance, pollutant, or contaminant to the environment.
3. The site is adequately characterized, and no hazardous substances remain on site, or no significant threat to human health or the environment exists.
4. Response actions are complete, and adequate measures have been taken to protect human health and the environment.

2.2.3 UST Regulations

The State of Hawaii adopted its own UST statutes and regulations (Hawaii Revised Statutes, Title 19, Chapter 342L and HAR, Title 11, Chapter 281, Subchapters 1 through 10) to implement these laws in Hawaii. Owners and operators of USTs that contain regulated substances such as petroleum are required to take specific actions when investigating releases from their USTs. Regulations and requirements are explained in detail in the TGM for Underground Storage Tank Closure and Release Response (HDOH, 2000), hereafter referred to as the TGM-UST.

2.2.4 EALs as “To Be Considered” Guidance

Where no specific regulatory standards exist for a chemical or situation, or where such standards are insufficiently protective, other guidance should be considered in determining the necessary level of cleanup to protect human health or the environment. Under the risk assessment process conducted in support of a UST site characterization, EALs, rather than the 1995 action levels in HAR Title 11, Chapter 281, subchapter 78 can be used to screen for constituents of potential concern (COPCs) as described in *Screening For Environmental Concerns At Sites With Contaminated Soil and Groundwater* (HDOH, 2005b).

According to HDOH (2005b):

The EALs are considered to be conservative. Under most circumstances, and within the limitations described, the presence of a chemical in soil, soil gas or groundwater at concentrations below the corresponding EAL can be assumed to not pose a significant, long-term (chronic) threat to human health and the environment. Additional evaluation will generally be necessary at sites where a chemical is present at concentrations above the corresponding EAL. Active remediation may or may not be required, however, depending on site-specific conditions and considerations.

and

The EALs are intended to serve as an update and supplement to the HDOH document Risk-Based Corrective Action and Decision Making at Sites With Contaminated Soil and Groundwater (June 1996). The change in terminology from "Risk-Based Action Levels" to "Environmental Action Levels" is intended to better convey the broad scope of the document and clarify that some action levels are not "risk-based" in a strict toxicological definition of this term. Use of the EALs is recommended not mandatory.

Table 2-1. Reporting Requirements for UST Release Response

REPORTING REQUIREMENTS FOR RELEASE RESPONSE (HAR 11-281, Subchapter 7)			
Report Description	How to Notify	When Report(s) Must be Submitted	Purpose of Report
Release Response Work Plan	Work Plan	Only when specifically requested by DOH	To provide DOH with detailed information on plans for undertaking any and all release response actions.
Confirmed Release Notification (CRN)	Phone or Fax	Within 24 hours after discovery of a release	To notify DOH of the UST release and response actions taken to date. Provides DOH with an opportunity to advise owners and operators on release response requirements.
	CRN Form	Within 7 days after discovery of a release	
Initial Release Response Report	Report	Within 90 days after discovery of a release	To inform DOH of all actions taken within the first 90 days in response to a UST release.
Quarterly Release Response Report	Report	Within 180 days after discovery of a release and every 90 days thereafter, in cases where release response actions exceed 90 days	To inform DOH of additional actions taken beyond the first 90 days.
Corrective Action Plan (CAP)	Work Plan	Submit workplan within 30 days following its request by DOH	To demonstrate that remedial action will be safe and protective of human health and the environment
Corrective Action Plan Quarterly Monitoring Report	Quarterly Release Response Report	CAP monitoring reports are required every 90 days	To demonstrate that CAP is operating and performing as anticipated and to describe the progress of cleanup

OPTIONS TO DEMONSTRATE PROTECTIVENESS OF HUMAN HEALTH AND THE ENVIRONMENT			
OPTION 1: COMPLIANCE WITH DOH'S TIER 1 ACTION LEVELS			
Report Description	How to Notify	When Report Must be Submitted	Purpose of Report
Tier 1 evaluation of soil and groundwater	Initial or Quarterly Release Response Report	When residual contamination is less than DOH's Tier 1 action levels	To verify adequacy of site characterization and that concentrations of any contaminants remaining on site are below Tier 1 action levels
OPTION 2: DEVELOPMENT OF TIER 2 SOIL ACTION LEVELS			
Site specific Tier 2 evaluation of soil contamination	Initial or Quarterly Release Response Report	When residual soil contamination is less than site specific Tier 2 action levels	To verify adequacy of site characterization and that the concentration of any soil contaminants remaining on site are below Tier 2 action levels for soil
OPTION 3: DEVELOPMENT OF TIER 3 RISK ASSESSMENT			
Risk Assessment	Initial or Quarterly Release Response Report	When alternative levels of risk can be demonstrated to be acceptable	To demonstrate through a formal and site specific risk assessment that residual contamination does not present an unacceptable risk to human health or the environment
OPTION 4: DEVELOPMENT OF EXPOSURE PREVENTION PLAN			
Exposure Pathway Assessment	Report	When exposure prevention can be shown to be a suitable remedy	To establish that no current exposure pathways to human and non-human receptors exists
Exposure Prevention Management Plan	Report	When exposure prevention can be shown to be a suitable remedy	To formalize all monitoring and response actions that will be taken to prevent exposure of human and non-human receptors to residual contaminants

2.3 Non-Regulatory Guidance on Release Detection To Be Considered for the Facility

Two important factors that must be taken into account in providing release detection at the Facility are given below.

1. Each UST in the Facility is field-constructed and has dome-shaped ends which are atypical for fuel tanks of this size. The large volume associated with each tank requires high resolution detectors to assess small changes in level, temperature and pressure. Algorithms for evaluating fuel movement must account for the atypical design.
2. The USTs within the Facility are interconnected with each other and with other facilities in Pearl Harbor. Fuel movement may be due to:
 - An inadvertent leak;
 - Fuel inflow or outflow, which should be accounted for via inventory management; and/or;
 - Movement between tanks within the Facility.

Procedures to account for these factors are not part of standard USEPA testing protocol for UST leak detection systems, which evaluate individual tanks. Guidance for certification is available for alternative testing methods for bulk field constructed tanks. In addition, differentiating chronic leaks from other fuel movement or other systemic sources require analysis of trends from multiple sensors and trained fuels specialists and a dedicated program. In this regard, FISC will implement a fuel management program that will include sensor specifications, data transfer systems, data storage, data analysis algorithms, and a user interface to allow the fuel specialist to evaluate unexplained fuel movement and determine whether a leak is occurring.

2.3.1 Alternative Leak Detection Methods for Bulk Field Constructed Tanks

There are several reasons why an alternative method is often required for bulk field constructed tanks.

1. Some release detection systems cannot be evaluated using the procedures described in the EPA Standard Methods for Evaluating Leak Detection Methods.
2. For some types of equipment, there is no EPA protocol available.
3. The cost to conduct the EPA Standard Method may be cost-prohibitive for some Fuel Storage Systems.

The following systems have been tested at the Red Hill Facility to date.

- Asteroid Corporation has tested their Comet system.
 - The Low Range Differential Pressure (LRDP) system developed by Naval Facilities Engineering Service Center (NFESC) was tested in a single tank configuration by a third-party certifier (Ken Wilcox Associates [KWA], 2002). The general protocol for these
-

single tank configuration tests have followed *Alternative Test Procedures For Evaluating Leak Detection Methods: For Bulk Field-constructed Tanks*, KWA, revised November 2000. This document is available at:

http://www.kwaleak.com/protocols/KWA_Bulk_Tank_Protocol_11_28_00_fonts_fixed.pdf.

- As part of an overall management system to evaluate fuel movement at the Pearl Harbor fuel storage and transmission facilities, Asteroid Corporation developed the concept of a Fuel Integrity Management Program (FIMP) with two major parts; Tank Integrity Management Program (TIMP) and Pipeline Integrity Management Program (PIMP). FIMP is a schematic description of a comprehensive release detection program for pipelines and tanks throughout the Pearl Harbor integrated fuel system.

The U.S. Navy is evaluating these and other methods in an effort to develop a viable leak detection system at the Facility.

2.4 Regulatory History of the Facility

This subsection provides a chronological listing of regulatory issues and documents submitted regarding the Facility UST petroleum releases. These documents can be found in Appendix A.

Date	Activity
December 7, 2000	HDOH Letter to Navy: Response to telephone report of release of jet fuel. Release ID No. 010011.
April 16, 2002	Confirmed Release Notification Form for Tank 6, JP-5 Fuel.
July 17, 2002	Confirmed Release Notification.
September 5, 2002	HDOH Letter to Navy: Thank you for briefing and visit to Red Hill Tank Complex on August 1, 2002. Note that petroleum contamination exceeding HDOH Tier 1 Action Levels was found beneath Tanks 1, 2, 6, 14, and 17 in 2001.
November 26, 2002	Navy Letter to HDOH: Transmittal letter, Final Red Hill Bulk Fuel Storage Facility Investigation Report, August 2002. Release ID Nos. 990051, 010011, 020028.
April 4, 2003	HDOH Letter to Navy: Comments on the Facility Investigation Report and requesting quarterly release reports and a comprehensive risk assessment.
July 21, 2003	HDOH Letter to Navy: Acknowledgement of receipt of Sampling and Laboratory Reports for testing at the Red Hill Adit No. 3 pumping station and request for additional sampling at the Facility, scale maps and figures, and a comprehensive risk assessment for the Facility.
October 10, 2003	HDOH Letter to Navy: Request for risk assessment, conceptual site model, scale maps and figures, quarterly monitoring reports of monitoring wells and the Adit No. 3 well, copies of documentation of engineering investigations of structural integrity or leakage at the Facility, and installation of a leak detection system for the tanks.
June 2, 2004	Scale Drawings of Red Hill Tanks Piping System.

Date	Activity
June 10, 2004	HDOH Letter to Navy: Request for the information listed in the October 10, 2003 letter.
July 8, 2004	Navy Letter to HDOH: Response to October 10, 2003 HDOH letter.
October 8, 2004	Navy Report Submitted to HDOH: Quarterly Progress Report.
August 12, 2004	HDOH Letter to Navy: Acknowledgement of receipt of April 29 Statement of Work for Long-term Monitoring/Remedial Action; May 4, 2004 Statement of Work for A-E Services for Planning Documents and Related Technical Services; May 6, 2004 email update; and July 8, 2004 Letter Report from the Navy.
January 13, 2005	Navy Report Submitted to HDOH: Quarterly Progress Report.
April 13, 2005	Navy Report Submitted to HDOH: Quarterly Progress Report.
May 4, 2005	Navy Letter to HDOH: Draft Work Plan.
July 12, 2005	Navy Report Submitted to HDOH: Quarterly Progress Report.
August 25, 2005	HDOH Letter to Navy: Acknowledgement of receipt of First Quarter 2005 Groundwater Sampling and June 2005 Red Hill Bulk Fuel Storage Facility Work Plan.
September 7, 2005	Navy Report Submitted to HDOH: Second Quarter 2005 Groundwater Sampling Report.
October 12, 2005	Navy Report Submitted to HDOH: Quarterly Progress Report.
November 28, 2005	Navy Report Submitted to HDOH: Third Quarter 2005 Groundwater Sampling Report.
January 13, 2006	Navy Report Submitted to HDOH: Red Hill Tank Complex Quarterly Progress Report.
January 25, 2006	Navy Report Submitted to HDOH: Red Hill Bulk Fuel Storage Facility, Draft –Addendum Planning Documents. Navy Report Submitted to HDOH: September 2005 Groundwater Sampling Results.
March 31, 2006	Navy Report Submitted to HDOH: Fourth Quarter 2005 Groundwater Sampling Report.
April 13, 2006	Navy Report Submitted to HDOH: Quarterly Progress Report.
April 19, 2006	HDOH Letter to Navy: Acknowledgement of receipt of June 2005 Red Hill Bulk Fuel Storage Facility Planning Documents; August 2005 and November 2005. Groundwater Sampling Reports; January 2006 Red Hill Bulk Fuel Storage Facility, Draft –Addendum Planning Documents; and January 2006 Red Hill Tank Complex Quarterly Progress
June 1, 2006	Navy Letter to HDOH: Red Hill Bulk Fuel Storage Facility, Final – Work Plan Addendum Planning Documents.
July 17, 2006	Navy Report Submitted to HDOH: Quarterly Progress Report.
September 5, 2006	Navy Report Submitted to HDOH: July 2006 Groundwater Sampling Results.
October 12, 2006	Navy Report Submitted to HDOH: Quarterly Progress Report.
January 8, 2007	Navy Letter to HDOH: Notification for USTs for Tanks 1 and 19.
January 11, 2007	Navy Report Submitted to HDOH: Red Hill Tank Complex Quarterly Progress Report.

Date	Activity
January 25, 2007	Navy Report Submitted to HDOH: December 2006 Groundwater Sampling Results.
April 13, 2007	Navy Report Submitted to HDOH: Quarterly Progress Report.
May 4, 2007	Navy Report Submitted to HDOH: March 2007 Groundwater Sampling Results.
July 13, 2007	Navy Report Submitted to HDOH: Quarterly Progress Report.
August 20, 2007	Navy Report Submitted to HDOH: June 2007 Groundwater Sampling Results.
August 23, 2007	Navy Letter to HDOH: Red Hill Bulk Fuel Storage Facility Final Technical Report
October 12, 2007	Navy Report Submitted to HDOH: Quarterly Progress Report.
October 16, 2007	Navy Report Submitted to HDOH: September 2007 Groundwater Sampling Results.

3 TANK PREVENTIVE MAINTENANCE AND LEAK MONITORING PROGRAM

The Facility overlies a very valuable groundwater resource that produces between 4.5 and 16 mgd of potable water for the PHWS and its military consumers via U.S. Navy well 2254-01. This water resource is virtually irreplaceable, considering the present limitations of the sustainable yield of the Pearl Harbor and Honolulu Aquifer Sectors, the available water, land, as well as construction costs for new sources.

A large release of petroleum LNAPL to groundwater from the Facility can eliminate the Red Hill sub-basin as a water resource to PHWS via U.S. Navy well 2254-01. Currently there is no effective way to quickly determine whether a release is occurring. Groundwater samples are collected quarterly; a chronic release of 8 gallons per hour over a period of 90 days is approximately 17,280 gallons. Groundwater model simulations indicate that a release of this size has the potential to allow contaminated water to enter the infiltration gallery and contaminate the U.S. Navy well 2254-01 at concentrations greater than the MCL for benzene (TEC 2007). Such contamination would require the well to be withdrawn from domestic service until a treatment plant and associated by-pass water transmission system were put in place.

The age of the Facility and the mission-critical requirements for its storage capacity combine to present a significant future risk of a moderate to large release of fuel to the underlying groundwater. In order to mitigate the risk associated with future releases, the U.S. Navy will:

1. Implement a rigorous tank maintenance program, and
2. Continue to research and investigate a viable leak detection system for the Facility. Deployment of a leak detection system is dependent on the suitability of available technologies and budget constraints.

Although the Facility USTs are deferred from many of the State and Federal regulations, including the requirement for release detection (HAR, Title 11, Chapter 281, Subchapter 5, "Release Detection") deployment of a reliable leak detection system would reduce the potential for a chronic release to the Red Hill sub-basin. The impact of a future chronic release of fuel over a prolonged period of time would:

1. Eliminate 4.5 mgd to 16 mgd of potable water from the PHWS, which would severely impact the U.S. Navy mission in the Pacific;
2. Be extremely difficult and costly to remediate in accordance with the HDOH UST regulations (HAR, Title 11, Chapter 281, Subchapter 7, "Release Response"); and
3. Remove the Red Hill sub-basin as a source of potable water for an undetermined period of time.

Although there is currently a network of three groundwater monitoring wells within the Facility, these wells are only sampled every three months, and each monitors approximately 200,000 square feet of the water table beneath the Facility. A release from Tank 12 could potentially

impact an area of the water table of 150,000 square feet before being intercepted at RHMW02 at Tank 6. For these reasons, it is clear that every effort must be made to ensure that these releases do not occur, and this will be accomplished by instituting a rigorous maintenance schedule, and continuing the effort to identify and implement state of the art release detection procedures.

3.1 Tank Maintenance and Repair Program

3.1.1 Tank Maintenance and Repair Histories

Data from modified API 653 Inspection Reports and existing written site histories (see Appendix B) are summarized here. In addition to actual leaks from the tanks, it should be noted that in some cases, reported leaks in histories were leaks into the tell-tale system piping itself (which are internal to the tank) and were not external tank leaks.

Dates	Tank 1 Activity
August 1953	Leak found on tell-tale no. 7 and crack found in tank during cleaning; no indication given of leakage rates.
8/64 to 9/67	Various leaks from tell-tale; unknown quantity of leakage.
8/70 to 4/72	Unexplained fuel drops amounting to 31,294 gallons.
5/75 to 8/78	Unexplained fuel drops amounting to 32,765 gallons.
10/81	Tank modernization repair project starts.
7/82 to 1/83	Leak tests result in fuel drops amounting to 5517 gallons.
9/99	End of history.
Dates	Tank 2 Activity
10/47	Tell-tale leak noted, unknown amount; tank emptied.
12/81	Tank removed from service for repair and lining.
4/83	End of history.
Dates	Tank 3 Activity
3/53 to 12/81	No leaks reported.
Dates	Tank 4 Activity
1/53 to 4/83	No leaks reported.

Dates	Tank 5 Activity
3/65	Tell-tale leak at 1 gallon per 1.25 hours; tank worked on intermittently for 6 months but no leak found; suspect leak in tell-tale system.
2/72	Tell-tale leak at 2 quarts per day; response uncertain.
4/83	End of history.
Dates	Tank 6 Activity
6/63	Problems with tell-tale system; no clear indication of external leaks.
3/83	End of history.
Dates	Tank 7 Activity
11/73	Tell-tale leakage, tank emptied; leak may have been internal only.
5/78	Significant tell-tale leakage, tank emptied.
2/80	After filling leak rates measured and approx. 6505 gallons leakage measured until rate dropped to < 13 gallons per day (gpd) below 207' fill level.
4-5/81	Tank removed from service for repairs and put back in service; end of history.
Dates	Tank 8 Activity
3/52 to 4/83	No leaks reported.
Dates	Tank 9 Activity
4/58 to 5/58	Approximately 1500 gallons leaked from tell-tale.
4/96	Report of a hole found under middle pipe support for 18" line; no details provided.
7/78 to 2/81	Tank repair project and installation of telemetering system; leak test rates after project range from 4.5 to 17.9 gpd; no documentation of any actions
Dates	Tank 10 Activity
1/73	Suspected leak; tank emptied.
4/76	Tell-tale leak; tank emptied and removed from service.
10/78 to 4/80	Tank repair project and installation of telemetering system.
1/81	During refill a severe leak detected somewhere near top of tank; fuel ran out on concrete near first platform on stairway to top of dome; tank emptied.
10/81	Started refilling tank after repair.
4/83	End of history.

Dates	Tank 11 Activity
8-9/80	Leak testing after repair and upgrade; rates from 165 to 2412 gpd over 1 month; based on these valued estimated fuel loss between 10,000 and 20,000 gallons.
9/80	Tank emptied and repaired.
1/81	End of history.
Dates	Tank 12 Activity
1/64	Reported that there is a known leak in the dome section; no other information
3/73	Tank emptied, suspected leak; no additional information given.
2/81	Leak testing after repair and upgrade showed leak rate of 1,400 gpd; Unknown amount of leakage.
5/81	Tank was removed from service for a second time for leak repairs; end of history.
Dates	Tank 13 Activity
5/76	Leak reported, no details.
9/81	Tank returned to service after lining and repairs; leaks found above 188 foot level; repaired.
2/82	End of history.
Dates	Tank 14 Activity
3/49 to 2/82	No leaks reported.
Dates	Tank 15 Activity
7/81	Tank leaked badly upon refilling after tank repair and lining, no details.
8/81 to 10/81	Removed from service, repaired; leak test still showed leak and repaired again.
1/82	End of history.
Dates	Tank 16 Activity
7/48	Leak reported, no details; emptied tank.
7/49	Tell-tale leak, lost 2.25" in 11 days (approx. 11,000 gallons); no additional information.
12/49	Tank refilled, lost 3.63" in 4 days (approx. 18,000 gallons); no information on when leakage was stopped.
5/73	Tell-tale leakage at 1 drop per 20 seconds; no additional information.
1/75	Emptied tank.

Dates	Tank 16 Activity (continued)
10/81	Tank refilled after repairs and lining and found to leak badly.
11/81	Tank removed from service.
12/81	Tank reworked and returned to service; end of history.
Dates	Tank 17 Activity
6/69	Leak reported by gauger; tell-tale leaking at 1 gallon per 1.5 minutes; fuel transferred.
1/75	Tell-tale started leaking; no additional information.
5/79	End of history.
Dates	Tank 18 Activity
12/50 to 9/75	No leaks reported.
Dates	Tank 19 Activity
6/64	Leak discovered around weld in tank bottom, 5 mL per hour (mL/hr); other small holes discovered during inspection; rewelded.
1998	“Back seepage” was observed from holes in steel liner during a tank maintenance project.
Dates	Tank 20 Activity
8/60 to 3/79	No leaks reported.

Based on various types of leak tests conducted since 1997, other releases may have occurred that are not reflected in the histories above. However, the accuracies of these tests are not known and in some cases leakage through gate valves has been determined as the cause of unexplained changes in fuel levels. In 2004, gate valves on fuel lines were replaced with twin seal plug valves (double block bleed valves). These replacements are believed to have eliminated leaky valves as a factor to explain unexpected changes in fuel levels.

3.1.2 Tank Inspections and Repairs

To date, five tanks (Tanks 7, 8, 10, 15 and 16) have been inspected and repaired in accordance with a modified protocol for USTs based on the API 653. API 653, *Tank Inspection, Repair, Alteration and Reconstruction*, is a maintenance and inspection program developed by the API to provide for an ongoing assessment of a facility’s above ground storage tanks. This protocol was modified to be appropriate for USTs. API 653 provides minimum requirements for maintaining the integrity of welded steel storage tanks. It applies specifically to aboveground tanks, but the principles also apply to field-constructed underground tanks. Tanks 7, 8, and 10 underwent the

modified API 653 process and were completed in 1998. Tanks 15 and 16 underwent the modified API 653 process and were completed early in 2007. The modified API 653 reports are provided in Appendix B.

3.1.3 Current Status of the USTs

At the date of this report, 17 of the 20 tanks at the Facility are in operation. Three tanks (1, 6 and 19) are currently out of service (Table 3-1). Tanks 1 and 19 have been taken out of service permanently (Appendix B). Tank 6 is presently undergoing modified API 653 tank inspection procedure (Appendix B).

3.2 Current Petroleum Release Monitoring Systems

3.2.1 Soil Vapor Monitoring System

The soil vapor monitoring system (SVMS) is not an ATG system. As implemented in the pilot study, the SVMS consists of two or more probes located at various points in existing boreholes beneath seven of the Facility tanks (2, 6, 10, 11, 12, 14 and 16). Each probe is used to draw vapor from isolated segments of the borehole associated with the front, middle, and back of the tanks. Vapors are withdrawn from each probe via a pump and sampled in the field using a hand-held organic compound detector. Total volatile organic vapors are measured down to 1 part per billion and compared to baseline measurements from the same location. Increasing concentrations over time are an indication of fuel leaks at the tested tank. The SVMPs can be monitored periodically (quarterly) or when data from the ATG leak detection system indicates a potentially leaking tank. All 20 tanks have horizontal borings underneath them from earlier investigations, therefore full scale implementation would require removal of the existing casing and SVMP installation in eleven additional boreholes (Tank 1 and Tank 19 are out of service indefinitely). Limitations of the SVMPs as currently designed are described below.

- Currently only one boring exists under each UST. Additional borings under each UST would increase the probability of detection by increasing the coverage.
 - In the case of multiple releases from a single UST, vapors from a previous release may mask any new releases to some extent, especially if the releases affected the same SVMP. This limitation may be overcome by evaluating concentration trends, versus the positive detections of petroleum as an indication of a new release. Additional borings and multiple vapor monitoring points per borehole would increase the probability of detection of multiple releases from different locations in a UST.
 - The remaining borings that have not been fitted are smaller in diameter and present technical difficulties in installation of the SVMPs with multiple monitoring points (MPs). Alternative installation procedures will be required.
-

3.2.2 Groundwater Monitoring at the Facility

Although a groundwater monitoring program is currently in place at the Facility, this program is not a viable leak detection method, since leaks can occur that are not observed at the monitoring wells. Its purpose is to evaluate groundwater quality under the Facility to determine whether contamination presents a risk to consumers of the water within the Red Hill sub-basin. In addition, the groundwater monitoring program will also provide "triggers" to the groundwater protection responses presented in Table 4-2. Petroleum in groundwater from each well can be inferred to have come from upgradient sections of the Facility; however, the objective of the leak detection program is to verify and correct any leakage before the drinking water resource is impacted in order to minimize the chance that the responses presented in Table 4-2 are required.

In the current configuration, three groundwater monitoring wells are in place within the lower access tunnel of the Facility.

- RHMW01 is at the southwest edge of the Facility, between Tank 1 and the U.S. Navy well 2254-01. RHMW01 is considered to be hydraulically downgradient from the USTs and is the last sentry well before the U.S. Navy well 2254-01 infiltration gallery. RHMW01 will be the first point of detection for releases from Tanks 1 through 6.
- RHMW02 is upgradient of Tank 6, approximately 600 feet upgradient of RHMW01. It will be the first point of detection for Tanks 7 through 14.
- RHMW03 is upgradient of Tank 14, approximately 800 feet upgradient from RHMW02 and 600 feet downgradient from Tanks 19 and 20. It is the first point of detection for Tanks 15 through 20.

The current groundwater monitoring program consists of quarterly sampling events, and results generally take two to three weeks from the time of sample collection. While this is a very important part of the confirmation process, it does not provide timely information required for protection of the groundwater resource. A detailed groundwater monitoring program has been developed for the Facility. This program is described in Section 4 of this report and in Appendix C (Groundwater Monitoring Field Sampling and Analysis Plan).

3.3 Ongoing Groundwater Protection Activities

1. Continue to conduct modified API 653 tank inspections and repairs for USTs (see proposed schedule in Table 3-1). This process is an extension of previous tank inspection and repair procedures that have been conducted to date. Tanks will continue to be inspected periodically at time intervals based on the results of the latest inspection (no greater than 20 years).
 2. Expand vapor monitoring program to all active Red Hill tanks. Currently seven active tanks are fitted with SVMPs. Install SVMPs in existing borings in the eleven remaining tanks as part of the overall fuel management program. The estimated cost to equip each tank with SVMPs is approximately \$15,000, for a total cost of \$165,000. An additional
-

\$10,000 is estimated for field instrumentation for real-time measurement of fuel vapors. Coordinate vapor monitoring of Tanks to same quarterly cycle as the well water monitoring cycle. An estimate of the cost to sample and assess a complete round of SVMPs from 18 tanks is approximately \$3,000. Integrate vapor monitoring into TIMP.

3. Continue quarterly groundwater monitoring of three wells within the Facility and the U.S. Navy well 2254-01 as required by the HDOH Release Response Requirements. The annual cost for the groundwater monitoring is approximately \$40,000.
4. Implement a market survey to evaluate best available technologies for leak detection on large field constructed bulk fuel storage facilities, such as the Facility. This will be a multi-phased project involving both identification of available technologies and pilot testing of potential candidate technologies. The initial step will consist of traditional research (internet, vendor specifications/literature, previous research studies, third party certification evaluations, etc.) to identify potential technologies. The study will evaluate systems based on applicability to the following Red Hill parameters:
 - o Proposed system leak detection sensitivity;
 - o Operational challenges; Relative costs; and
 - o Third party certifications.
5. Implement pilot studies of technologies that show promise on one or more of the tanks at Red Hill. Pilot testing will be done to evaluate the challenges associated with testing these tanks as well as the results versus cost to implement.

3.3.1.1 Reporting Tank Inspections, Leaks, and Releases to HDOH

Quarterly reports will continue to be provided to HDOH. These reports will contain the following:

1. Monitoring results from quarterly groundwater sampling.
 2. Results from any soil vapor testing that is conducted.
 3. Progress in developing a leak detection system for tank fluids and results from leak detection testing after the method is certified and accepted by FISC.
 4. Any other information regarding leaks or groundwater contamination.
 5. Modified API 653 Inspection and Repair scheduling and reports.
 6. Notification that tanks were taken out-of-service (HDOH Form 1).
-

Table 3-1. Tank Inspections and Scheduling

Tank #	Prior Years	FY06	FY07	FY08	FY09	FY10	FY11
1		Ongoing	RFS				
2				Scheduled			
3						Scheduled	
4							Scheduled
5					Scheduled		
6				Ongoing			
7	Completed FY98						
8	Completed FY98						
9					Scheduled		
10	Completed FY98						
11						Scheduled	
12					Scheduled		
13					Scheduled		
14				Scheduled			
15			Completed				
16			Completed				
17					Scheduled		
18					Scheduled		
19			RFS				
20				Scheduled			

RFS – Removed from Service (HDOH Form 1 submitted)
Schedule may be changed based on the needs of the U.S. Navy

This page intentionally left blank.

4 GROUNDWATER MONITORING PROGRAM, EVALUATION OF RESULTS, AND RESPONSE ACTIONS

4.1 Groundwater Monitoring Program

4.1.1 Regulatory Requirements

The HDOH October 10, 2003 letter specified quarterly groundwater monitoring for the Facility and specific analytical requirements as follows.

- For the monitoring wells within the Facility, the HDOH recommended quarterly monitoring for the following chemical constituents: BTEX, methyl tert butyl ether (MtBE), benzo(a)pyrene, acenaphthene, fluoranthene, naphthalene, and total lead.
- For the U.S. Navy well 2254-01, the HDOH recommended quarterly monitoring for the following chemical constituents: BTEX, MtBE, benzo(a)pyrene, acenaphthene, fluoranthene, naphthalene, and total dissolved lead.
- In addition, the HDOH requested a written description of the method of collection for drinking water samples at the U.S. Navy well 2254-01.

Since 2003, HDOH has published guidance that contains additional compounds of concern in groundwater investigations (HDOH EALs). To comply with the older requirements and recommendations as well as the new guidance, the Navy has implemented a groundwater monitoring system that is described in the following subsections and detailed in Appendix C.

4.1.2 Groundwater Monitoring Network

The current monitoring system consists of three wells, which partition the Facility into three segments:

- RHMW01 will monitor releases from Tank 1 through Tank 6, the southern extent of the Facility (Zone 1);
- RHMW02 will monitor releases from Tank 7 through Tank 14, the middle of the Facility (Zone 2); and
- RHMW03 will monitor releases from Tank 15 through Tank 20, the northern extent of the Facility (Zone 3).

The width of each zone is approximately 300 feet, consisting of a cross section of the tunnel and adjacent tanks. Zones 1, 2, and 3 are approximately 500 feet long, 700 feet long and 500 feet long, respectively. Because of the length of each zone, if releases occur at the furthest point from the well in each zone, the plume size could be 700 feet long before it is observed in the associated monitoring well. A chronic release may not be detected for some time under these circumstances, potentially resulting in a large plume of fuel on the water table. For this reason, the U.S. Navy will evaluate additional leak detection systems so that chronic releases may be detected in a timelier manner.

4.1.3 Groundwater Sampling and Analysis Protocol

The sampling and analysis will be conducted in accordance with the Sampling and Analysis Plan (SAP) (Appendix C). The SAP contains sampling and analytical details, which are summarized here. The sampling will be performed quarterly on wells RHMW01, RHMW02, RHMW03, and at RHMW2254-01 installed in U.S. Navy well 2254-01 (Figure 1-4). At a minimum, the following chemicals will be monitored, as per the October 10, 2003 HDOH letter:

- For monitoring wells RHMW01, RHMW02, and RHMW03 – BTEX, MtBE, benzo(a)pyrene, acenaphthene, fluoranthene, naphthalene and dissolved lead.
- For U.S. Navy well 2254-01 - BTEX, MtBE, benzo(a)pyrene, acenaphthene, fluoranthene, naphthalene and total dissolved lead.
- In addition, groundwater samples will be analyzed for TPH both in the volatile petroleum hydrocarbon (VPH) range, or as TPH-GRO (as defined by Method 8015 modified for Leaking Underground Storage Tank [LUST]); and extractable petroleum hydrocarbon (EPH) range, or as TPH-DRO (as defined by Method 8015 modified LUST).

Analytical methods will conform to SW846 solid waste groundwater testing protocol, including:

- Method 8260 for VOCs;
- Method 8270, Method 8310, or Method 8270 SIM for PAHs;
- Method 8015 for TPH-DRO and TPH-GRO; and
- Method 6010 for dissolved lead.

Reporting limits for the chemicals monitored will be below the HDOH EALs (HDOH, 2005). The environmental laboratory that conducts analyses described above will be accredited by the National Environmental Laboratory Accreditation Conference (NELAC).

4.2 Groundwater Analytical Results

At a minimum, groundwater analytical results will be provided in electronic format, as both EPA level 3 Sample Delivery Group (SDG) and as an Excel database or similar formatted database output. An example Table of Contents for the EPA level 3 SDG package is included in Appendix D. An example of the formatted database is also provided in Appendix D. The U.S. Navy will store and maintain these data sets while the Facility is an active fuel storage facility.

- The electronic database files will be merged into a complete database of all monitoring results, which will be used to evaluate concentration trends over time.
- Concentration trends will be evaluated for each chemical or mixture (such as TPH) that exceeds the Tier 1 action levels for drinking water or HDOH drinking water EALs.

The U.S. Navy will submit quarterly to the HDOH UST Division:

- The SDG data package;
-

- A tabular analytical results table summarizing for each well sampled: each tested chemical, the analytical result, the method detection limit, the reporting limit, any data qualifier, the date of sample collection, and a comparison to HDOH drinking water EALs; and
- A trend analysis of each chemical or mixture that exceeds Tier 1 action levels for drinking water or HDOH drinking water EALs.

4.3 Groundwater Action Levels

Action levels used for decisions at the Facility will include general HDOH EALs (HDOH 2005) for groundwater protection and SSRBLs for TPH and benzene. Through modeling it was determined that TPH and benzene are the risk drivers for migration of dissolved petroleum from jet fuel. SSRBLs were selected based on a Tier 3 Risk Assessment (TEC, 2007) and are valid at RHMW01, RHMW02 and RHMW03. For the protection of the U.S. Navy well 2254-01, the approach used was to select an exposure point concentration (EPC) at the U.S. Navy well 2254-01 that is acceptable based on risk considerations and then use fate and transport models to determine what monitoring point concentration would result in that EPC. The acceptable EPC concentrations at U.S. Navy well 2254-01, are the HDOH EALs. These EALs are listed in Table 4-1.

The SSRBLs are based on results from fate and transport modeling for petroleum (based on a JP-5 product) from the Facility to receptors (see Section 1.7.3.3 for the summary). Table 4-1 identifies the SSRBLs based on fate and transport results and risk assessment.

The actions to be taken are discussed in the next section.

4.3.1 STEP 1: Compare Analytical Results to Action Levels and Conduct Trend Evaluation

A comparison of sample results made to EALs and SSRBLs. An example table format for the comparison, and an example of the recommended Mann-Kendall trend analysis are shown in Appendix D.

The Mann-Kendall non-parametric statistical test can be used to show if contamination concentrations are decreasing or increasing over time. This test has no distributional assumptions, and missing data, “non-detects” and irregularly spaced measurements are allowed (Waterloo Hydrologic, 2005). “Non-detects” or values below the method detection limit, are assigned a single value equal to ½ the lowest detection limit. For every result, N, Mann-Kendall sums the number of following results that are greater than (+1), equal to (0), or less than (-1) preceding values. The resulting value is the Mann-Kendall S statistic in which a large positive number indicates a strong increasing trend, a small positive or negative number indicates little or no trend, and a large negative number indicates a strong decreasing trend.

There are several different approaches to calculating the Mann-Kendall S statistic. For small data sets, the data is assembled in the order in which it was collected, and a triangular table is created.

A single value (*e.g.*, ½ the lowest detection limit) is assigned to the “non-detect” values, in order to avoid assessing detection limit changes. Data is compared sequentially; the value from event 1 is compared to subsequent events 2 through n (value 2 – value 1, ..., value n – value 1), then the value from event 2 is compared to subsequent events 3 through n, with the last comparison being between the value from event n-1 to the value from the final event n. Comparisons are assigned a value of +1 or -1 if they are positive or negative, respectively. If both numbers are the same, the comparison is assigned a zero value. The number of positive, negative and zero values are summed across each row and used to calculate the S statistic. The data is then tested for negative or positive trends by comparing the number of data and the absolute value of S to a lookup table with confidence levels.

Table 4-1. Action Levels

Chemical	EAL (µg/L)	SSRBL (µg/L)
Volatiles		
Benzene	5	750
Ethylbenzene	700	NA
Methyl Tert Butyl Ether	10.59	NA
Toluene	1,000	NA
Xylenes	10,000	NA
Semi-volatiles		
Acenaphthene	365	NA
Benzo(a)pyrene	0.2	NA
Fluoranthene	1,460	NA
Naphthalene	6.22	NA
Lead		
Total	Not set	Not set
Dissolved	15	NA
Other		
TPH	100	4,500

NA – Not applicable or not determined

SSRBLs are applicable at RHMW01, RHMW02, and RHMW03

EALs are applicable at U.S. Navy well 2254-01

4.3.2 STEP 2: Take Actions for Results That Exceed the Specified Action Levels

The actions to be taken for exceedences at specific wells and for specific categories are listed in Table 4-2. These actions are dependent on the concentration of a compound at a specific well related to EALs and SSRBLs and groundwater concentration trends.

Table 4-2. Responses to Groundwater Monitoring Results

Results Category	RHMW02 or RHMW03	RHMW01	U.S. Navy Pumping Well 2254-01
Results Category 1: Result above detection limit but below drinking water EAL and trend for all compounds stable or decreasing	A	A	A,D,M,E,P
Results Category 2: Trend for any compound increasing or drinking water EAL exceeded	A, B	A, B	A,B,C,D,E,F,G,K, L,O
Results Category 3: Result Between 1/10X SSRBL and SSRBL for benzene, or between 1/2X SSRBL and SSRBL for TPH	A,B,G,H,I,J	A,B,E,G,H,I,J	A,B,C,D,E,F,G,I,J, K,L,O
Results Category 4: Result Exceeding any SSRBL or petroleum product measured or observed	A,C,D,E,F,I,J, K,M,N	A,C,D,E,F,I, J,K,M,N,O	A,C,D,E,F,G,I,J,K, L,O

Specific Responses:

- A. Send quarterly reports to HDOH
- B. Begin program to determine the source of leak
- C. Notify HDOH verbally within 1 day and follow with written notification in 30 days
- D. Notify FISC Chain of Command within 1 day
- E. Send Type 1 Report (see box below) to HDOH
- F. Send Type 2 Report (see box below) to HDOH
- G. Increase monitoring frequency to once per month (if concentrations increasing)
- H. Notify HDOH verbally within 7 days and follow with written notification in 30 days
- I. Remove sampling pumps (see Appendix C), measure product in pertinent wells with interface probe, re-install pumps if product is not detected.
- J. Immediately determine leaking tank
- K. Collect samples from nearby Halawa Deep Monitoring Well (2253-03) and OWDF MW01
 For permission to sample 2253-03, call DLNR Commission on Water Resource Management (808) 587-0214, DLNR.CWRM@Hawaii.gov
- L. Provide alternative water source at 2254-01
- M. Prepare for alternative water source at U.S. Navy Well 2254-01
- N. Re-measure for product every month with reports to HDOH
- O. Install additional monitoring well downgradient

Report Types

HDOH Type 1 Report

- Re-evaluate Tier 3 Risk Assessment/groundwater model results
- Proposal to HDOH on a course of action

HDOH Type 2 Report

- Proposal for groundwater treatment

If an anomalous result is suspected, the Navy may immediately resample a well or may have results validated by a third party before these results are accepted. These will be completed within 30 days from receipt of the original result.

4.4 Responsibilities

Navy Region Hawaii, Regional Environmental Department has the ultimate responsibility for implementation of this plan, including reporting to HDOH. Other responsibilities are shown in Table 4-3.

Table 4-3. Navy Chain of Command and Responsibilities for Implementing the Groundwater Protection Plan

Name	Day Phone	24-Hour Phone	Role
Compliance Division, Navy Region Hawaii Environmental Department	471-1171		Official Correspondence with HDOH; supports implementation of this Groundwater Protection Plan; ultimate responsibility for implementation of this Groundwater Protection Plan
FISC Fuels Systems Analyst	473-7890	479-0127	Implements this Groundwater Protection Plan; coordinates leak detection testing and implementation; determines when a leak should be reported; prepares monthly reports and other reports
FISC General Engineer	473-7892		Arranges and coordinates quarterly groundwater sampling, tank inspections, verbal notifications to HDOH and follow-up written notification
C703 Fuel Operations Foremen	473-7805	479-1063	Reports releases or problems
Underground Pump- house Dispatcher	471-8081	471-8081	Facility Emergency Coordinator
NAVFAC Pacific Public Works Water Commodity Engineer	473-0958		Manages the Pearl Harbor Water System; responsible for coordinating activities associated with U.S. Navy well 2254-01
Navy On-Scene Coordinator Navy Region Hawaii Environmental Department	473-4689		Responsible for clean up activities associated with the Pearl Harbor Oil and Hazardous Substance Groundwater Protection Plan, Facilities Response Plan and leads the Spill Management Team

This page intentionally left blank.

5 CONTINGENCIES FOR CONTAMINATION OF POTABLE WATER

The results of groundwater modeling indicates that a large petroleum release from the Facility to the underlying basal drinking water table has the potential to contaminate the U.S. Navy well 2254-01 (TEC, 2007). If this were to occur, the possible actions to ensure protection of human health would include one or a combination of the following: using alternative water sources, treatment of water pumped from the well, and/or water rationing. This section is provided as a conceptual overview of the issues and a limited number of alternatives. In the hypothetical future scenario where remediation of the basal aquifer is required, an emergency remedial alternatives analysis and engineering feasibility study and design would be conducted before implementation.

5.1 Potential Alternative Sources of Potable Water

The current configuration of the PHWS (which includes U.S. Navy well 2254-01) is shown in Figure 5-1 and details are specified in Tables 5-1 and 5-2. If the U.S. Navy Pumping well 2254-01 well became contaminated, a reduction in service would occur. The current demand of the PHWS fluctuates between 18 mgd in the winter to a maximum of approximately 30 mgd during limited periods in the summer months, supplied by the U.S. Navy well 2254-01, Waiawa Shaft, and Halawa Shaft. While there are short periods during the winter months when potable water from the Waiawa and Halawa Shaft meet the PHWS requirements, these are temporary, on the order of 1 to 2 weeks. During the summer months, all three wells are required to meet the water demand. During the summer months, U.S. Navy well 2254-01 provides as much as 10 mgd, or approximately 33 percent of the PHWS demand. While the HBWS has interconnecting piping from the HBWS Halawa Shaft (2354-01), these are low volume connections and could not replace the loss from Red Hill. Over-pumping from any of these wells, and especially the U.S. Navy Halawa Shaft will result in saltwater up-coning and intrusion that is unacceptable for these freshwater sources.

Tables 5-1 and 5-2 provide summary information, including theoretical pumping capacities for the PHWS wells.

5.2 Water Treatment Options

In the case where an inadvertent fuel release from the Facility to the water table occurred that is large enough to impact the quality of the water produced at the U.S. Navy well 2254-01, cleanup can be expected to take decades or more. As such, a water treatment facility may be required to remove the contaminants at the wellhead, as well as in situ groundwater treatment technologies to remove the contaminants from the groundwater resource. Wellhead treatment facilities should be designed to allow treatment of approximately 16 mgd at the U.S. Navy well 2254-01.

In the event that groundwater concentrations become unacceptable and a response requires groundwater treatment, the potential treatment options for the Facility are briefly described here.

Table 5-1. Summary of Pearl Harbor Water System

Water System Name	Pearl Harbor Water System , Pearl Harbor, Oahu, HI 96860
Water System Operator Phone Number	808-473-0388
Water System Identification Number	PWS 360
Location (City/Town)	Pearl Harbor
Population Served from EPA Records	52,326 people
Water Source Type	Groundwater
Water Source Information	Waiawa Shaft, Halawa Shaft, and U.S. Navy well 2254-01
Water Pumping Information	Halawa, Red Hill, Manana, and Moanalua Booster Pumps
Water Storage Information	Halawa Storage Tanks, Red Hill Storage Tank, and Camp Smith Storage Tanks
Water Treatment Information	NaOCl for chlorine disinfection and NaF for fluoridation
Water System Controls	SCADA system located in Watch Office at Plant No. 2
Water System Demand	Average Day Demand is 20.1 million gallons per day (MGD)

Source: Pearl Harbor Water System Emergency Response Plan (Earth Tech, 2005)

Table 5-2. Summary of Pearl Harbor Water System Components

Component	Facility	Capacity	Notes
Waiawa Shaft	S-71	18 MGD maximum production capacity	4 pumps rated at 7,200 gpm each
Halawa Shaft	1/487	5 MGD maximum production capacity	4 pumps rated at 3,200 gpm each
U.S. Navy well 2254-01	S-307	16 MGD maximum production capacity	2 pumps rated at 7,200 gpm each and 2 pumps rated at 6,500 gpm each
Red Hill Booster Pumps	S-307	2 pumps rated at 500 gpm each	Transfer to Red Hill storage tank
Halawa Booster Pumps	S-5	2 pumps rated at 500 gpm each	Transfer to Camp Smith storage tanks
Manana Booster Pumps		817	Transfer of water to Manana Housing
Moanalua Booster Pumps	2450	2 pumps rated at 130 gpm each	Emergency transfer of water to Moanalua Housing (not generally used)
Moanalua Booster Pumps	7001	2 pumps rated at 875 gpm each and 1 pump rated at 250 gpm	Transfer of water to Moanalua Housing

Source: Pearl Harbor Water System Emergency Response Plan (Earth Tech, 2005)

Based on the treatment technologies screening matrix (FRTR, 2007; see Appendix E) and an analysis of site-specific conditions, the treatment technologies most likely to be feasible are described further.

5.2.1 Summary of Potable Water Treatment Facility Technologies

In 1999, the U.S. Navy developed an engineering cost estimate for a water purification facility for the U.S. Navy well, Waiawa Shaft to remove trace organic contaminants from the pumped water from agricultural pesticides. This information is summarized in the Waiawa Water Treatment Plant 1391 provided in Appendix E. This treatment plant consisted of 45 granular activated carbon (GAC) filters, pump modifications and supporting laboratory facilities to be constructed near the Waiawa potable water facility. The estimated construction cost for this treatment plant was approximately \$28,300,000. This treatment plant was designed to treat 18 mgd that is produced by the U.S. Navy well, Waiawa Shaft.

Another technology that may be considered is air stripping wellhead treatment. In September of 1986, an air stripping potable water treatment plant was installed at Schofield Barracks to remove TCE from water pumped from the underlying aquifer. The facility treated approximately 3 to 6 mgd as of August of 1990 (<http://www.epa.gov/superfund/sites/npl/nar972.htm>). The process included one bag filter unit per well, one air-stripper unit per well, and a common collection and distribution system for all three wells and treatment units. The installed system consisted of three treatment units, each rated at 1,500 gallons per minute (gpm), which were designed to be connected to the existing three production wells. Operational cost estimates were based on the assumption that the system will operate such that only two wells and two treatment units are extracting and treating groundwater at any given time. Thus, one well and one treatment unit are on standby or in maintenance. This configuration provided for continuous treatment of 4.3 mgd of groundwater. According to the Record of Decision, EPA Superfund Record of Decision: SCHOFIELD BARRACKS (USARMY), EPA ID: HI7210090026, OU 02 SCHOFIELD, HI, 02/07/1997 (<http://www.epa.gov/superfund/sites/rods/fulltext/r0997032.pdf>), cost for treatment included:

- Capital costs of \$650,000;
- Annual operation and maintenance costs of \$217,000; and
- An estimated net present worth of \$3,990,000 based on a 5 percent return and 30-year project life.

5.2.2 Summary of Groundwater Treatment Technologies

Due to the location of the Facility, groundwater treatment would be technically challenging. In general, fuel located on groundwater beneath the Facility would require intrusive techniques, such as drilling, to begin the removal process. Due to the locations of the USTs within the Red Hill Ridge, drilling from ground surface would require:

- Diagonal drilling with boreholes extending 200 to 300 feet through fractured basalt and clinker zones from the point of entry, drilling from limited access roads; or
- Horizontal drilling extending from 300 to 500 feet through fractured basalt and clinker zones from the point of entry from the Red Hill Ridge top limited to between Tanks.

Success of pump and treat methods of fuel removal from the water table are further limited by the high hydraulic conductivity of the basal aquifer, which requires very large pumping capacities to generate draw-downs to induce contaminant migration to the pumping location. These require large pumps and large boreholes, which are extremely costly. Smaller cones of depression would require larger numbers of boreholes. Under the site conditions, secondary source removal may not be practical. In order to protect the very important groundwater resource, a combination of remediation techniques may be recommended, including secondary source removal between the Tanks from the ground surface through processes such as multi-phased extraction, and downgradient in situ remediation processes, such as enhanced bioremediation and air sparging.

In general, all intrusive remediation techniques would rely on an array of boreholes from ground surface to at least 20 feet below groundwater. Pilot studies would be required to determine the radius of influence of the systems, however, estimates of 20 feet lateral to flow are reasonable, thus an estimate of 35 feet between remediation wells could be considered. It is assumed that a minimum array of two rows of eight wells would be required: one located within 100 feet down gradient of the release, and one located at the downgradient perimeter of the Facility, between Tanks 1 and 2 and the Red Hill potable water infiltration gallery for U.S. Navy well 2254-01.

5.2.2.1 Pump and Treat Evaluation

Pump and treat remediation processes may be required for the first phase of the remediation of a large LNAPL plume. High volume pumps would require larger diameter boreholes, on the order of 15 inches for 13-inch casing. Specific capacities of wells in the area range from 100 gpm to greater than 300 gpm per foot of drawdown. These large specific capacities present several important challenges.

- Facilities must be prepared to treat the effluent at rates at greater than 100 gpm per well or a total of 16,000 gpm to induce drawdown at all wells.
- Large capacity pumps will be required to induce the drawdown.
- Treatment facilities must be located at low elevations to counter the ground surface depth to water, which can be expected to be greater than 400 feet. As such, water would be piped to a distant location, possibly adjacent to Adit 3.

In addition to the groundwater pumps, fuel product skimmers will also be required within the same borehole and multi-phased extraction systems also include soil vapor extraction or SVE within the same borings. The design of this system would be complex and require a concerted

effort to develop. The development and installation would be very costly, and overall efficiency could be poor due to the fractured rock nature of the aquifer.

5.2.2.2 Enhanced Bioremediation Evaluation

The rate of bioremediation of organic contaminants by microbes is enhanced by increasing the concentration of electron acceptors and nutrients in ground water, surface water and leachate. Oxygen is the main electron acceptor for aerobic bioremediation. Nitrate serves as an alternative electron acceptor under anoxic conditions. Each of the wells within the array not used for pump and treat would be available to deliver oxygen to the groundwater as a reactive permeable barrier. One method for introducing oxygen into the impacted aquifer is by direct air sparging, in which blowers would be required to bubble air through the saturated zone penetrated by the wells. While blowers are economical sources of air, they are not particularly efficient in ensuring well-oxygenated groundwater. Other potential oxygen sources are patented oxygen release compounds, which can be pumped into the aquifer via the well array, or patented gas infusion technology, both which use supersaturated conditions and time-release mechanisms to provide a much more efficient oxygenation of the aquifer to induce bioremediation. Additional information is available at http://toxics.usgs.gov/topics/rem_act/o2_relcompound.html.

This page intentionally left blank.

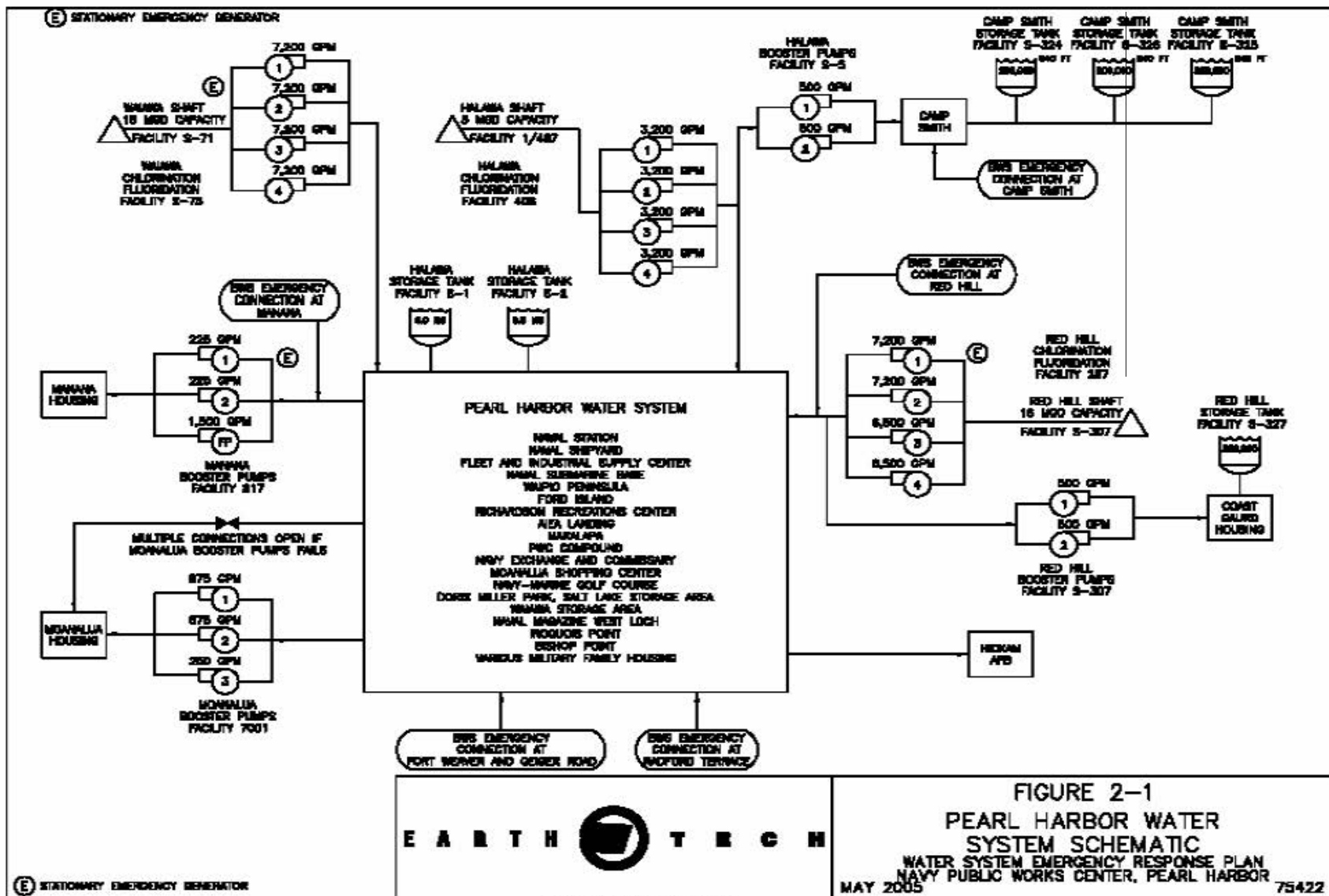

Figure 5-1 Pearl Harbor Water System Schematic
 Red Hill Storage Facility, Pearl Harbor, Hawaii

FOR OFFICIAL USE ONLY

FIGURE 2-1
 PEARL HARBOR WATER
 SYSTEM SCHEMATIC
 WATER SYSTEM EMERGENCY RESPONSE PLAN
 NAVY PUBLIC WORKS CENTER, PEARL HARBOR
 MAY 2005 75422

This page intentionally left blank

6 REFERENCES

- AMEC Earth and Environmental, Inc. (AMEC). 2002. Red Hill Bulk Fuel Storage Facility Investigation Report. Prepared for NFEC. August.
- Code of Federal Regulations (CFR) Title 40, Part 141.
- Earth Tech, Inc. (Earth Tech). 2005. Water System Emergency Response Plan, Volume I - Policies and Procedures Manual, Pearl Harbor, Hawaii. May.
- Federal Remediation Technologies Roundtable. Remediation (FRTR) Technologies Screening Matrix. http://www.frtr.gov/matrix2/section3/table3_2.html. Accessed Jan, 2007.
- Gilbert, W.J, 1987. Statistical Methods for Environmental Pollution Monitoring, Van Nostrand Reinhold.]
- Hawaii Administrative Record (HAR) Title 11. Chapters 20, 281, 451.
- Hawaii Revised Statutes Title 19, Chapters 128D and 342L.
- Hawaii Department of Health (HDOH). 1995b. State Contingency Plan. Hawaii Administrative Rules, Chapter 11-451. August 1995.
- HDOH. 1996. Risk Based Corrective Action and Decision Making at Sites with Contaminated Soil and Groundwater, Honolulu, Hawaii. State of Hawaii, Department of Health, Environmental Management Division. Revised June 1996.
- HDOH. 1997. Draft Edition: Technical Guidance Manual for the Implementation of the Hawaii State Contingency Plan. Hazard Evaluation & Emergency Response. October 1997.
- HDOH. 2000. Technical Guidance Manual for Underground Storage Tank Closure and Release Responses. Environmental Management Division Solid and Hazardous Waste Branch, Underground Storage Tank Section. March 2000.
- HDOH. 2003. Interim Draft: Screening for Environmental Concerns at Sites with Contaminated Soil and Groundwater. Environmental Management Division. December 2003.
- HDOH. 2005. Screening for Environmental Concerns at Sites with Contaminated Soil and Groundwater. Interim Final. May. Updated November 2006.
- HDOH. 2005b. Use of May 2005 Environmental Action Levels ("EALs") at Leaking Underground Storage Tank Sites. Memo from Steven Chang, Chief, Solid & Hazardous Waste Branch To Interested Parties. July 15.
- National Work Group on Leak Detection Evaluations, May 2006, Glossary of Terms, <http://www.nwglde.org/glossary.html>, Accessed January 20, 2007
- TEC Inc., 2005. Red Hill Bulk Fuel Storage Facility Work Plan. Prepared for Department of the Navy, Commander Naval Facilities Engineering Command, Pacific. June.
-

United States Environmental Protection Agency (USEPA), NPL Site Narrative for Schofield Barracks, <http://www.epa.gov/superfund/sites/npl/nar972.htm>, Accessed June 26, 2007.

USEPA, EPA Superfund Record of Decision: Schofield Barracks (USARMY) EPA ID: H17210090026, OU 02, Schofield, Hawaii, EPA/ROD/R09-97/032, 1997.

United States Geological Survey (USGS) 2007, Oxygen Release Compound Remediation Tests, Toxic Substances Hydrology Program, http://toxics.usgs.gov/topics/rem_act/o2_relcompound.html. Accessed June 25, 2007

Appendix A
Hawaii Department of Health Correspondence

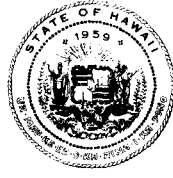

STATE OF HAWAII
DEPARTMENT OF HEALTH
P. O. BOX 3378
HONOLULU, HAWAII 96801

In reply, please refer to:
EMD/SHW

December 7, 2000

U12014RT

Mr. John Muraoka
Navy Region Hawaii
Regional Environmental Department
517 Russell Avenue, Suite 110
Pearl Harbor, Hawaii 96860

Dear Mr. Muraoka:

SUBJECT: Red Hill Underground Storage Tank Facility
Facility ID 9-102274 / Release ID 010011
102274

This letter is in response to your telephone report of December 1, 2000 regarding a release of jet fuel at the subject facility.

Chapter 11-281 of the Hawaii Administrative Rules entitled, "Underground Storage Tanks" requires UST owners and operators to investigate and clean up releases of regulated substances from their UST systems. To assist you in complying with these requirements, the Department of Health has prepared a guidance document, entitled: *Technical Guidance Manual for Underground Storage Tank Closure and Release Response* (March 2000), which is available for download at our website at:
<http://www.state.hi.us/doh/eh/shwb>.

The following identifies the type and content of reports which should be submitted to our office after a confirmed release:

1. **Confirmed Release Notification Form** - Submit this form within 7 days of identifying the release (HAR, 11-281-72).
2. **Current Evidence of Financial Responsibility** - Submit current evidence of financial responsibility (for example, a copy of a current UST insurance policy) within 30 days of identifying the release (HAR, 11-281-110).
3. **Initial Release Response Report** - Includes information on initial abatement, initial site characterization, soil & groundwater investigation, free product recovery (if necessary) and notification of members of the public directly affected by the release (11-281.78.1a). Submit this report within 90 days of identifying the release (HAR, 11-281-80.1).

Mr. John Muraoka
December 7, 2000
Page 2

4. **Quarterly Release Response Report** - If release response has not been completed within 90 days of identifying the release, submit this report within 180 days of the release date and every 90 days thereafter until release response actions have been completed (HAR, 11-281-80.1).

Please initiate release response activities as soon as practicable and please note that we do not require prior approval of plans for response activities at UST release sites. Therefore, you may be relying heavily on the recommendations of your environmental consultant.

Selection of a qualified consultant is of great importance. The consultant you select should be capable of performing all necessary environmental services and providing all necessary reports and documentation to demonstrate compliance with the UST release response requirements and all other environmental laws applicable to the response activities at your facility.

We appreciate your cooperation and prompt attention to this matter. Please include your UST Facility ID number and Release ID number on all future correspondence regarding this release. If you have any questions regarding this letter, please contact me at the Underground Storage Tank Section, (808) 586-4226.

Sincerely,



RICHARD TAKABA
Environmental Health Specialist
Underground Storage Tank Section
Solid and Hazardous Waste Branch

APPENDIX 5-B

CONFIRMED RELEASE NOTIFICATION FORM

STATE USE ONLY			
Facility ID:	Release ID: 02102X	Date Sent:	Date Received:
GENERAL INFORMATION AND INSTRUCTIONS			
This form should be completed immediately and only after reporting a confirmed release by telephone within 24-hours to the Hawaii DOH UST Section. Completion of this notice will serve to fulfill part of the notification requirements of HAR 11-84-71. Please type or print in ink all items except "Signature" in Section III. This form must be completed for each UST release occurrence. Completed form must be mailed to: Department of Health, Solid and Hazardous Branch, 919 Ala Moana Boulevard, Room 212, Honolulu, Hawaii 96814			
I. REPORTING PARTY AND FACILITY INFORMATION			
24-Hour Reporting Party Name, Title, & Affiliation:			
John Santo Salvo, LCDR, USN, Director, FISC Fuel Department			
Facility Name & Address:			
Red Hill Tank Complex, FISC Pearl Harbor			
Facility Contact Person, Affiliation, & Address:			
John T. Muraoka, Envir. Engr., CNR-HI Ph: (808) 471-1171			
Facility Information: (Check only one item)			
<input type="checkbox"/> Gas Station	<input type="checkbox"/> Aircraft Owner	<input type="checkbox"/> State Government	<input type="checkbox"/> Commercial
<input type="checkbox"/> Petroleum Distributor	<input type="checkbox"/> Auto Dealership	<input type="checkbox"/> Federal Non-Military	<input type="checkbox"/> Industrial
<input type="checkbox"/> Airline	<input type="checkbox"/> County Government	<input checked="" type="checkbox"/> Federal Military	<input type="checkbox"/> Truck/Transportation
<input type="checkbox"/> Utilities	<input type="checkbox"/> Other		
II. RELEASE INFORMATION (Circle all that apply in items A-F)			
A. Source of the Release: Piping Tank(s) Spill Overfill			
If "Tank(s)" list tank sizes: Tank 6, 13 million gallons			
B. Method of Discovery & Confirmation: Closure Monthly Release Detection Tightness Test Site Check			
Other (Specify): Inventory check			
C. Estimated Quantity of Substance Released: Gallons X Unknown			
D. Type of Substance Released: Unleaded Gas Leaded Gas Diesel Used or Waste Oil Hazardous Substance			
Other (Specify): JP-5 Fuel			
E. Immediate Hazards: Explosion Fire Vapor Exposure Recoverable Free Product Drinking Water Threat			
Other (Specify): None			
F. Release Impact: Surface Water possible Ground Water X Soil Air			
G. Migration Pathways: None Utility Conduits Subsurface Drains Sewer Lines XX Unknown			
Other (Specify):			
H. Actions Taken: Evacuated Nearby Area/Removed UST Contents/Recovered Free Product/Excavated Soils/Ground Water/Recovery			
Other (Specify): Tank has been drained and taken out of service			
III. UST OWNER OR OPERATOR CERTIFICATION (Read and sign after completing all sections to the extent possible)			
I certify under penalty of law that I have examined and am familiar with the information submitted in this notice, and that based upon my inquiry of those individuals immediately responsible for obtaining the information, I believe that the submitted information is true and accurate.			
Name, Title, & Company:			
John Santo Salvo, LCDR, USN, Director, FISC Fuel Department			
Signature: 		Date: 4/16/02	
DOH Form CRN (8/92)			



DEPARTMENT OF THE NAVY

COMMANDER
NAVY REGION HAWAII
517 RUSSELL AVENUE, SUITE 110
PEARL HARBOR, HAWAII 96860-4884

IN REPLY REFER TO:

5090
Ser N465/ 00222

CERTIFIED MAIL NO. 7001 1940 0006 1626 3077

17 JUL 2002

Hawaii State Department of Health
Environmental Management Division
Solid and Hazardous Waste Branch
Underground Storage Tank Section
919 Ala Moana Boulevard Suite 212
Honolulu HI 96814

SUBJECT: CONFIRMED RELEASE NOTIFICATION FOR RELEASE AT RED HILL TANK
COMPLEX, FLEET AND INDUSTRIAL SUPPLY CENTER (FISC) PEARL
HARBOR

Gentlemen:

In accordance with Subchapter 7, Chapter 281, Title 11 of the Hawaii Administrative Rules, and as discussed during the meeting at the State of Hawaii DOH on July 2, 2002, enclosure (1) is submitted. The suspected releases were discovered during a preliminary site investigation of the Red Hill Tank Complex. The final report should be completed shortly, and will be forwarded to your office as soon as it is available. We are submitting a single Confirmed Release Notification form for the entire Red Hill Tank Complex, even though previous notifications were made for suspected releases at tanks 6 and 16. This is because any response or remedial actions from now on will likely be directed at the Complex as a whole instead of at individual tanks. We will notify your office of follow on actions at a later date.

If there are any questions regarding this matter, please contact Mr. John T. Muraoka at (808) 471-1171, extension 214.

Sincerely,

R. M. WAKUMOTO
Director (Acting)
Regional Environmental Department
By direction of
Commander, Navy Region Hawaii

Enclosure: 1. State of Hawaii Confirmed Release Notification Form for
Red Hill Tank Complex, FISC Pearl Harbor

Copy to: Commanding Officer, Fleet Industrial Supply Center, Pearl
Harbor (Code 700)

BENJAMIN J. CAYETANO
GOVERNOR OF HAWAII



BRUCE S. ANDERSON, Ph.D., M.P.H.
DIRECTOR OF HEALTH

STATE OF HAWAII
DEPARTMENT OF HEALTH
P. O. BOX 3378
HONOLULU, HAWAII 96801

In reply, please refer to:
EMD/SHW

September 5, 2002

U09003RT

Mr. John Muraoka
Navy Region Hawaii
Regional Environmental Department
517 Russell Avenue, Suite 110
Pearl Harbor, Hawaii 96860

Dear Mr. Muraoka:

SUBJECT: Red Hill Tank Complex
Facility ID Nos.: 9-100994, 9-102257, 9-102259, 9-102260, 9-102261,
9-102262, 9-102263, 9-102264, 9-102265, 9-102266, 9-102267,
9-102268, 9-102269, 9-102270, 9-102271, 9-102272, 9-102273,
9-102274, 9-102275, 9-102978/Release ID Nos. 990051, 010011, 020028

Thank you for the briefing and visit to the Red Hill Tank Complex on August 1, 2002.

The Department of Health (DOH) has reviewed the draft reports submitted for the facility. We note that petroleum contamination exceeding DOH Tier 1 Action Levels was found beneath Tank 1, Tank 2, Tank 6, Tank 14, and Tank 17 during 2001.

Please forward final versions of the previously submitted draft reports and other release response documentation to our office within the next 30 days. DOH will review the final reports and submit its comments to you.

Should you have any questions regarding this letter, please contact Mr. Richard Takaba of our Underground Storage Tank section at (808) 586-4226.

Sincerely,



STEVEN Y.K. CHANG, P.E., CHIEF
Solid and Hazardous Waste Branch



DEPARTMENT OF THE NAVY

COMMANDER
NAVY REGION HAWAII
517 RUSSELL AVENUE, SUITE 110
PEARL HARBOR, HAWAII 96860-4884

IN REPLY REFER TO:

5090
Ser N465/ 00330

26 NOV 2002

CERTIFIED MAIL NO. 7001 1940 0006 1626 4357

Mr. Steven Y. K. Chang, P. E., Chief
Solid and Hazardous Waste Branch
State of Hawaii
Department of Health
P. O. Box 3378
Honolulu HI 96801

SUBJECT: RED HILL TANK COMPLEX FACILITY ID NOS.: 9-100994, 9-102257,
9-102259, 9-102260, 9-102261, 9-102262, 9-102263, 9-102264,
9-102265, 9-102266, 9-102267, 9-102268, 9-102269, 9-102270,
9-102271, 9-102272, 9-102273, 9-102274, 9-102275,
9-102978/RELEASE ID NOS. 990051, 010011, 020028

Dear Mr. Chang:

In response to your letter, U09003RT of September 5, 2002, the Final Report of the Red Hill Bulk Fuel Storage Facility Investigation is being provided as enclosures 1 through 3 for your concurrence.

We apologize for not providing the final report within 30 days, but additional time was required by our customer (DESC-PAC) to allow their Headquarters to review and comment on the final document submittal. DESC-PAC and the Naval Petroleum Office concurs with the recommendation in the report to conduct a risk assessment in conjunction with fate and transport modeling. The next phase of work will not be scoped until the State Department of Health comments are received/reviewed by DESC. The next phase of work is currently planned for execution in FY04.

If you should have any questions, please contact Mr. Darren Uchima of our Regional Environmental Department at 471-1171 extension 217.

Sincerely,

M. T. WOLFERSBERGER
Lieutenant, CEC, U. S. Navy
Director
Regional Environmental Department
By direction of
Commander, Navy Region Hawaii

- Enclosures: 1. Red Hill Bulk Fuel Storage Facility Investigation Report
(Final) of August 2002 Volume I of III.
2. Red Hill Bulk Fuel Storage Facility Investigation Report
(Final) of August 2002 Volume II of III.
3. Red Hill Bulk Fuel Storage Facility Investigation Report
(Final) of August 2002 Volume III of III.

LINDA LINGLE
GOVERNOR OF HAWAII



STATE OF HAWAII
DEPARTMENT OF HEALTH
P. O. BOX 3378
HONOLULU, HAWAII 96801-3378

N465
N460
N465
Darren
ack
plr
4/17
CHIYOME L. FUKINO, M.D.
DIRECTOR OF HEALTH

In reply, please refer to:
EMD/SHWB

April 4, 2003

U04007RT

Mr. Darren Uchima
Navy Region Hawaii
Regional Environmental Department, N465
517 Russell Avenue, Suite 110
Pearl Harbor, Hawaii 96860-1884

Dear Mr. Uchima:

SUBJECT: Red Hill Tank Complex
Facility ID No. 9-102271 / Release ID No. 990051

The Department of Health (DOH) has reviewed the following reports:

1. "Comprehensive Long-Term Environmental Action Navy (CLEAN) for Pacific Division, Naval Facilities Engineering Command, Pearl Harbor, Hawaii, Volume I, Part 1," dated August 2002 and prepared by AMEC Earth & Environmental, Inc. (AMEC);
2. "Comprehensive Long-Term Environmental Action Navy (CLEAN) for Pacific Division, Naval Facilities Engineering Command, Pearl Harbor, Hawaii, Volume I, Part 2," dated August 2002 and prepared by AMEC;
3. "Comprehensive Long-Term Environmental Action Navy (CLEAN) for Pacific Division, Naval Facilities Engineering Command, Pearl Harbor, Hawaii, Volume II, Part 1," dated August 2002 and prepared by AMEC;
4. "Comprehensive Long-Term Environmental Action Navy (CLEAN) for Pacific Division, Naval Facilities Engineering Command, Pearl Harbor, Hawaii, Volume II, Part 2," dated August 2002 and prepared by AMEC;
5. "Comprehensive Long-Term Environmental Action Navy (CLEAN) for Pacific Division, Naval Facilities Engineering Command, Pearl Harbor, Hawaii, Volume III, Part 1," dated August 2002 and prepared by AMEC; and
6. "Comprehensive Long-Term Environmental Action Navy (CLEAN) for Pacific Division, Naval Facilities Engineering Command, Pearl Harbor, Hawaii, Volume III, Part 2," dated August 2002 and prepared by AMEC.

Case # 991990

Mr. Darren Uchima
April 4, 2003
Page 2

The reports were received on November 26, 2002. Please note that the aforementioned documents now reside with the public record for the subject facility.

Thank you for visiting with DOH on February 5, 2003 to discuss the confirmed underground storage tank releases of the United States Navy in the State of Hawaii. DOH requests clarification on the following issues:

1. Statement found in Section 2.10, page 2-6 of Volume I, Part 1:
"Until recently, ground-water quality on the islands of Hawaii has been of high quality. Realizing the importance of fresh potable drinking water, Hawaii has effectively used land management practices as a safeguard to protect ground-water quality."

Please provide an explanation for the stated, "until recently," with references and actual dates.

2. Statement found in Section 2.11, page 2-7 of Volume I, Part 1:
"The closest known ground water extraction point intersecting the basal aquifer is located in the Red Hill water supply tunnel in Adit #3. Approximately 8 to 12 mgd are withdrawn from this location and account for 10% of Honolulu's water supply (USGS, 1991)."

Please provide scale maps and figures identifying the precise location and distance of the ground water extraction point to the tanks and piping of the Red Hill Tank Complex.

3. Statement found in Section 2.11, page 2-7 of Volume I, Part 1:
"The basal aquifer is tapped as a source of drinking water by the Navy PWC and supplies the drinking water for the Pearl Harbor Naval Complex. The pumping station is located within the lower tunnel system and approximately 0.5 miles to the west of the bulk fuel storage tanks. Regular testing of the basal aquifer is conducted through the PWC pump station by the PWC and by the Hawaii Department of Health (DOH) to ensure that the water is maintained within drinking water standards."

Please provide scale maps and figures identifying the precise location and distance of the pumping station to the tanks and piping of the Red Hill Tank Complex. In addition, please provide analytical data on all groundwater monitoring conducted at the pump station by PWC and DOH during 2001 and 2002, including dates, staff performing the sampling, laboratory, analytical method, detection limits, and reported results.

4. The reports state that a monitoring well was installed within the Red Hill Tank Complex which penetrated the drinking water aquifer. Please provide scale maps and figures identifying the precise location and distance of this groundwater

Mr. Darren Uchima
April 4, 2003
Page 3

monitoring well to the tanks and piping of the Red Hill Tank Complex, and any documentation of permitting issued by the Hawaii Department of Land and Natural Resources.

Because the Red Hill Tank Complex is a confirmed underground storage tank release site, the Navy is required to send quarterly release response reports to this office every 90 days. The format for a quarterly release response report is found in Appendix 5-E (enclosed) of our *Technical Guidance Manual for Underground Storage Tank Closure and Release Response, 2nd Edition*.

DOH also requests that all future reports for your facility contain soil and groundwater analytical results, in separate tables, including minimum detection limits and reporting results for the following chemical constituents only: TPH-g, TPH-d, TPH-o, benzene, toluene, ethylbenzene, xylenes, MtBE, benzo(a)pyrene, acenaphthene, fluoranthene, naphthalene, total lead.

The analytical results of your submitted reports show each soil/rock sample was analyzed for 118 chemical compounds. Please compile a separate results table for all compounds not found in the preceding list. In addition, the data tables in your submitted reports lack clearly identifiable sample origins. All analytical results should clearly indicate the location or monitoring well of origin with corresponding maps or figures.

DOH notes that petroleum contamination exceeding DOH Tier 1 Action Levels for "drinking water threatened" was found beneath Tank 1, Tank 2, Tank 6, Tank 14, Tank 16 and Tank 17. At this time, DOH requests that a comprehensive risk assessment for the Red Hill Tank Complex be performed as soon as possible. Please provide a scope of work and schedule for conducting the risk assessment.

Should you have any questions regarding this letter, please contact Mr. Richard Takaba of our Underground Storage Tank Section at (808) 586-4226.

Sincerely,

STEVEN Y.K. CHANG, P.E., CHIEF
Solid and Hazardous Waste Branch

Enclosure

RTakaba echa health state hi us

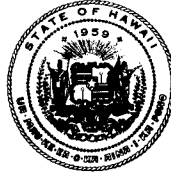

STATE OF HAWAII
DEPARTMENT OF HEALTH
P. O. BOX 3378
HONOLULU, HAWAII 96801-3378

In reply, please refer to:
EMD/SHWB

July 21, 2003

U07026RT

Mr. Darren Uchima
Navy Region Hawaii
Regional Environmental Department, N465
517 Russell Avenue, Suite 110
Pearl Harbor, Hawaii 96860-1884

Dear Mr. Uchima:

SUBJECT: Red Hill Tank Complex
Facility ID No. 9-102271 / Release ID Nos. 990051, 010011 & 020028

The Department of Health (DOH) has reviewed the following documents:

1. Your e-mail correspondence dated July 7, 2003;
2. *"Safe Drinking Water Branch Chain of Custody & Inorganic Chemicals Report,"* for Red Hill Adit No. 3 Water Pumping Station dated November 21, 2002;
3. *"Navy Public Works Center Environmental Laboratory,"* documentation for water sampling at Red Hill Adit No. 3 Water Pumping Station dated July 26, 2002;
4. *"Navy Public Works Center Environmental Laboratory,"* documentation for water sampling at Red Hill Adit No. 3 Water Pumping Station dated August 9, 2001; and
5. *"Safe Drinking Water Branch Chain of Custody & Synthetic Organic Chemicals Report,"* for Red Hill Adit No. 3 Water Pumping Station dated May 17, 2001.

These documents were received on July 7, 2003. Please note that the documents now reside with the public record for the subject facility.

DOH's letter to you dated April 4, 2003 requested scale maps and figures identifying the precise location and distance of the groundwater extraction points to the tanks and piping of the Red Hill Tank Complex. The e-mail message sent on July 7, 2003 stated

Mr. Darren Uchima
July 21, 2003
Page 2

that Figure 1-2 of the *Red Hill Bulk Fuel Storage Facility Investigation Report Volume I of III* would satisfy our request. Unfortunately, Figure 1-2 does not indicate the location or presence of piping connected to the 20 underground storage tanks (USTs) of the Red Hill Tank Complex in relation to the groundwater extraction points, or the Red Hill Adit No. 3 Water Pumping Station. DOH defines a UST system as the UST plus all connected piping. This information will be critical to your planned Tier III Risk Assessment for the facility.

As stated in our April 4, 2003 letter, the Red Hill Tank Complex is a confirmed UST release site and the Navy is required to submit quarterly release response reports to this office every 90 days. These reports should include groundwater monitoring data from the wells installed within the facility. As these are groundwater monitoring wells and not drinking water wells, analytical results, including minimum detection limits and reporting results, should be submitted for the following chemical constituents only: benzene, toluene, ethylbenzene, xylenes, MtBE, benzo(a)pyrene, acenaphthene, fluoranthene, naphthalene, and total lead. If additional analyses are performed, please include the results in a separate table.

At this time, DOH requests the Navy to develop a work plan for a comprehensive risk assessment for the Red Hill Tank Complex. We look forward to meeting with you soon to discuss the work plan and the schedule of implementation. Should you have any questions regarding this letter, please contact Mr. Richard Takaba of our Underground Storage Tank Section at (808) 586-4226.

Sincerely,



STEVEN Y.K. CHANG, P.E., CHIEF
Solid and Hazardous Waste Branch



STATE OF HAWAII
DEPARTMENT OF HEALTH
P. O. BOX 3378
HONOLULU, HAWAII 96801-3378

In reply, please refer to:
EMD/SHWB

October 10, 2003

U10018RT

Mr. Darren Uchima
Navy Region Hawaii
Regional Environmental Department, N465
517 Russell Avenue, Suite 110
Pearl Harbor, Hawaii 96860-1884

Dear Mr. Uchima:

SUBJECT: Red Hill Tank Complex
Facility ID No. 9-102271 / Release ID Nos. 990051, 010011 and 020028

The Department of Health (DOH) would like to thank you for the presentation and tour of the Red Hill Tank Complex on August 12, 2003. As stated in our letter of July 21, 2003, a comprehensive Tier III Risk Assessment is requested for the Red Hill Tank Complex in accordance with 5.4.4 of our *Technical Guidance Manual for Underground Storage Tank Closure and Release Response, 2nd Edition (TGM)*, and Appendix 5-H of the TGM, *Format for a Risk Assessment Report*. We recommend that your consultant contact toxicologist Barbara Brooks or ecological risk assessor Clarence Callahan of DOH's Hazard Evaluation and Emergency Response Office to ensure that your Tier III Risk Assessment is prepared according to DOH standards.

Due to the uncertainties regarding petroleum releases from the facility, the following is also strongly recommended:

1. Comprehensive site conceptual model, including a fate and transport model for contamination from the facility, flow modelling to receptors, and contingency plan to protect the Navy's Halawa Adit No. 3 Drinking Water Pumping Station.
2. As stated in our letter of July 21, 2003, scale maps and figures identifying the precise location and distance of the groundwater extraction points to the tanks and piping of the Red Hill Tank Complex are required in your next quarterly progress report. Your e-mail message sent on July 7, 2003 stated that Figure 1-2 of the submitted *Red Hill Bulk Fuel Storage Facility Investigation Report, Volume I of III*, would satisfy this request. Unfortunately, Figure 1-2 does not indicate the location or presence of piping connected to the 20 underground storage tanks (USTs) of the Red Hill Tank Complex in relation to the groundwater extraction points, or the Red Hill Adit No. 3 Water Pumping Station, or the pipelines which connect the facility to Pearl Harbor, Hickam Air Force Base, the former Barbers Point Naval Air Station,

or any other facilities. DOH defines a UST system as the UST plus all connected piping. This information is required and will be critical to your planned Tier III Risk Assessment for the facility.

3. As stated in our letters of April 4, 2003 and July 21, 2003, the Red Hill Tank Complex is a confirmed UST release site and the Navy is required to submit quarterly release response reports to this office every 90 days. These reports must include groundwater monitoring data from the wells installed within the facility. As these are groundwater monitoring wells and not drinking water wells, analytical results, including minimum detection limits and reporting results, should be submitted for the following chemical constituents: benzene, toluene, ethylbenzene, xylenes, MtBE, benzo(a)pyrene, acenaphthene, fluoranthene, naphthalene, and total lead. If additional analyses are performed, please include the results in a separate table.

4. We are aware that DOH's Safe Drinking Water Branch requires comprehensive testing of the Navy's Adit No. 3 Drinking Water Pumping Station every three years. Due to the fact that 100 million to 200 million gallons of jet fuel and fuel oil are stored in the Red Hill Tank Complex, this office recommends quarterly testing of the Adit No. 3 Drinking Water Pumping Station for the following chemical constituents: benzene, toluene, ethylbenzene, xylenes, MtBE, benzo(a)pyrene, acenaphthene, naphthalene, and total dissolved lead. In addition, DOH requests a written description of the method of collection for drinking water samples at the Adit No. 3 Drinking Water Pumping Station.

Copies of any documentation of engineering investigations of structural integrity or leakage of Red Hill Tank Complex.

6. Installation of a leak detection system for each of the 20 field-constructed USTs in the Red Hill Tank Complex.

If you have any questions regarding this letter, please contact Mr. Richard Takaba of our Underground Storage Tank Section at (808) 586-4226.

Sincerely,

STEVEN Y.K. CHANG, P.E., CHIEF
Solid and Hazardous Waste Branch

- c: Matt Small, U.S. EPA Region 9
Barbara Brooks, Hazard Evaluation and Emergency Response Office
Clarence Callahan, Hazard Evaluation and Emergency Response Office
William Wong, Safe Drinking Water Branch



STATE OF HAWAII
DEPARTMENT OF HEALTH
P. O. BOX 3378
HONOLULU, HAWAII 96801-3378

In reply, please refer to:
EMD/SHWB

June 10, 2004

U06010RT

CERTIFIED MAIL NO. 7002 2410 0003 0561 1622
RETURN RECEIPT REQUESTED

NOTICE OF VIOLATION
REQUEST FOR INFORMATION

Mr. Darren Uchima
Navy Region Hawaii
Regional Environmental Department, N465
517 Russell Avenue, Suite 110
Pearl Harbor, Hawaii 96860-1884

Dear Mr. Uchima:

SUBJECT: Red Hill Tank Complex
Facility ID 9-102271 / Release IDs 990051, 010011 & 020028

During the telephone conference between representatives of the Department of Health (DOH) and the Navy on December 11, 2003, a number of issues were discussed, including the documentation requested in DOH's letter of October 10, 2003. To date, DOH has not received the requested documentation from the Navy, or the required quarterly progress reports.

The first confirmed underground storage tank (UST) release for the Red Hill facility was reported on October 28, 1998. Since that time, two additional confirmed releases have been reported and logged. Under the UST laws, the Navy should have submitted twenty-one (21) quarterly progress reports. DOH has received none.

Hawaii Administrative Rules (HAR) section 11-281-80.1 requires owners and operators to submit quarterly progress reports that set forth all response actions taken in response to the release and a plan for future response actions. Failure to submit the reports is considered a violation of the UST laws and could lead to the assessment of penalties by DOH pursuant to Hawaii Revised Statutes (HRS) sections 11-281-8 and 11-281-10. In light of the Navy's failure to submit the progress reports, DOH is requesting that the Navy submit the progress reports pursuant to the authority of Hawaii Revised Statutes (HRS) section 342L-7(a) which provides:

For the purpose of developing or assisting in the development of any rule, conducting any study, taking any release response action, or enforcing this chapter, any owner or operator of an underground storage tank or tank system,

Mr. Darren Uchima
June 10, 2004
Page 2

and any person involved in response actions relating to any releases from these tanks or tank systems, upon the request of any duly authorized representative of the department, shall:

1. Furnish information relating to the tanks or tank systems, including tank equipment and contents and any response actions relating to the release from the tanks or tank system;
2. Conduct monitoring or testing; and
3. Permit the designated representatives at all reasonable times to have access to, and to copy all records relating to the tanks or tank systems.

In accordance with HRS §342L-7(a), DOH hereby requests that the Navy submit: (1) all overdue quarterly reports to DOH; (2) an explanation as to why the reports were not submitted when due; and (3) the documentation DOH requested in its letter of October 10, 2003 (attached), ***within twenty-one (21) calendar days after your receipt of this letter.***

Pursuant to HAR § 342L-10(b)(2), if the Navy fails to provide the information requested herein, DOH may assess fines against the Navy up to \$500 for each day it fails to provide the information. The Navy's response to this request for information should be sent to:

Mr. Richard Takaba
Project Officer
Solid and Hazardous Waste Branch
Hawaii Department of Health
919 Ala Moana Boulevard, Room 212
Honolulu, Hawaii 96814

Pursuant to HRS 92F, HRS section 342L-7, and 342L-15, DOH is required to make any records, reports, or information that you submit available to the public, absent a satisfactory showing of confidentiality. If you believe that any information you are submitting in response to this letter is entitled to confidential treatment, please submit a cover letter at the time you submit the information to DOH identifying: (1) the particular information that you believe should be kept confidential; and (2) any reason(s) why the information is entitled to confidential treatment under HRS chapter 92F. Failure to make such a request may result in the information being released to a third party.

Mr. Darren Uchima
June 10, 2004
Page 3

DOH appreciates your prompt attention to this request for information. If you have any questions regarding this letter, please contact Mr. Richard Takaba of our Underground Storage Tank Section at (808) 586-4226.

Sincerely,

STEVEN Y.K. CHANG, P.E., CHIEF
Solid and Hazardous Waste Branch

Enclosure

c: Matt Small, U.S. EPA Region 9
Barbara Brooks, Hazard Evaluation and Emergency Response Office
Clarence Callahan, Hazard Evaluation and Emergency Response Office
William Wong, Safe Drinking Water Branch



DEPARTMENT OF THE NAVY

COMMANDER
NAVY REGION HAWAII
850 TICONDEROGA ST STE 110
PEARL HARBOR HI 96860-5101

5090
Ser N465/

00296

02 JUN 2004

CERTIFIED MAIL NO. 7002 3150 0003 9288 7182

Mr. Richard Takaba
Underground Storage Tank Section
Solid & Hazardous Waste Branch
Environmental Management Division
State of Hawaii Department of Health
919 Ala Moana Boulevard Room 212
Honolulu HI 96814

SUBJECT: RED HILL TANK COMPLEX
FACILITY I.D. NO. 9-102271/RELEASE I.D. NOS. 990051, 010011 AND
020028

Dear Mr. Takaba:

In response to item 2 of your letter dated October 10, 2003, we are providing scale drawings of the Red Hill Tank Piping in enclosure (1). Please be aware that these drawings are sensitive information and is requested to be utilized by the State of Hawaii for "Official Use Only".

The Red Hill Tank Piping Drawings identify all piping from the Red Hill Storage Tank Complex to the Upper Tank Farm. The drawings also identify the location of the Red Hill Adit No. 3 Water Pumping Station. FISC does not have any other scale drawings available which identify piping from the Upper Tank Farm to the Hickam Air Force Base or Barbers Point Naval Air Station Facilities.

In reference to Figure 3-1 of the "Red Hill Bulk Fuel Storage Facility Investigation Report" Volume I of III, the groundwater extraction points can be located with relation to the baseline stationing identified on both drawings.

If there are any questions regarding this matter, or if more information is needed, please contact Mr. Darren Uchima at (808) 471-1171, extension 217.

Sincerely,

R. M. WAKUMOTO
Director
Regional Environmental Department
By direction of
Commander, Navy Region Hawaii

Enclosure: 1. Scale Drawings of Red Hill Tanks Piping System (7 sheets)



DEPARTMENT OF THE NAVY

COMMANDER
NAVY REGION HAWAII
850 TICONDEROGA ST STE 110
PEARL HARBOR HI 96860-5101

5090 00360
Ser N465/
08 JUL 2004

CERTIFIED MAIL NO. 7001 2510 0007 4418 7856

Mr. Richard Takaba
Project Officer
Solid and Hazardous Waste Branch
Hawaii Department of Health
919 Ala Moana Boulevard Room 212
Honolulu HI 96814

SUBJECT: RED HILL TANK COMPLEX
FACILITY I.D. NO. 9-102271/RELEASE I.D. NOS. 990051,
010011 AND 020028

Dear Mr. Takaba:

In response to the State of Hawaii Department of Health Letter, U06010RT, we received on June 24, 2004, we are providing the following information as requested.

The first confirmed underground storage tank (UST) release for the Red Hill facility was reported on October 28, 1998. From October 1998 through November 2002, the Navy was in process of securing funds, preparing the scope of work, awarding a contract for site investigation, and finalizing the site investigation report. While no actual response actions had started, the Navy had verbal communications with the DOH. In response to Hawaii Administrative Rules (HAR) section 11-281-80.1, the Navy will be providing the DOH formal quarterly progress reports beginning with this report.

The following items of work have been documented.

In March 1998, the Navy authorized AMEC Earth and Environmental Inc. (AMEC) to proceed with engineering services. The site characterization was conducted in two phases: Phase I - Research Activities and Phase II - Investigation Activities.

In April 1998 AMEC conducted the research activities which included site reconnaissance and data gathering activities.

From October through November 1998 the first of two tasks of the Phase II portion was conducted. This included a limited investigation of two of the twenty tanks.

5090
Ser N465/ 00: 3
08 JUL 2004

From October 2000 through March 2001 the second task of the Phase II portion was conducted. This task was to investigate the remaining 18 tanks and the basal aquifer, and to prepare and submit a Phase II investigation Report.

From April 2001 through August 2002 AMEC provided a draft and final submittal with various customer reviews.

On November 26, 2002, the Navy transmitted the Final Report of the Red Hill Bulk Fuel Storage Facility Investigation (3 volumes) to DOH.

On April 4, 2003, DOH response letter U04007RT requested clarification on a few items from the Navy's November 26, 2002, letter.

On July 7, 2003, DOH received requested information sent to the Navy on April 4, 2003.

On July 21, 2003, DOH response letter U07026RT confirmed receipt of clarification items and requested additional information including work plans for a comprehensive risk assessment for the Red Hill Tank Complex.

On August 12, 2003, CNRH met with Environmental Protection Agency (EPA), FISC, DOH and PWC to discuss the history of the Red Hill Tank Complex and to visit the site.

On October 10, 2003, DOH sent response letter U10018RT to the Navy requesting various items of work to be accomplished.

On December 11, 2003, the CNRH, PACDIV, EPA and DOH held a telephone conference to go over in detail the items of work requested by DOH in their letter to the Navy dated October 10, 2003.

On January 13, 2004, consultant recommended by EPA and DOH to help prepare risk assessment met with FISC and PWC personnel and was introduced to the Red Hill Tank Complex.

On April 22, 2004, Fleet Industrial Supply Center (FISC) held a meeting with Commander Navy Region Hawaii (CNRH), Pacific Division Naval Facilities Engineering Command (PACDIV), Navy Petroleum Office (NAVPET), Defense Energy Service Center (DESC), and Public Works Center (PWC) Pearl Harbor to discuss and finalize direction of work items requested by State of Hawaii Department of Health letter dated October 10, 2003, regarding the Red Hill Tank Complex.

5090
Ser N465/ 00360
08 JUL 2004

On May 6, 2004, the Navy sent an e-mail to the DOH to provide an update of events with respect to the DOH letter dated October 10, 2003.

On June 2, 2004, the Navy provided DOH scale drawings of the Red Hill Tank Complex piping as requested in your letter dated October 10, 2003.

On June 4, 2004, the Navy e-mailed the scope of work of the risk assessment for the Red Hill Tank Complex to DOH as requested.

On June 8, 2004, the Navy awarded a contract to Dawson Group Inc. to prepare sampling protocols and to collect samples from the vertical monitoring well (MW-V1D) and from the stilling basin at the PWC potable water infiltration tunnel at Red Hill.

On June 24, 2004, DOH response letter U06010RT required the Navy to provide quarterly progress reports beginning in July 2004.

On June 25, 2004, DOH commented on the scope of work of the risk assessment by e-mail.

The next quarterly progress report will be provided to the DOH in October 2004.

In response to your request for information of documentation requested in your letter of October 10, 2003, we have the following information to provide.

Item 1. The Navy is in process of awarding a contract to have a consultant prepare a risk assessment. Proposals are due July 26, 2004.

Item 2. Scale drawings identifying the precise location and distance of the groundwater extraction points to the tanks and the piping of the Red Hill Tank Complex were transmitted to the DOH on June 3, 2004. These drawings are for "Official Use Only".

Item 3. On June 9, 2004, The Navy awarded a contract to (1) have a contractor prepare a sampling protocol for collecting samples from the vertical monitoring well (MW-V1D) and from the stilling basin at the PWC potable water infiltration tunnel at Red Hill and (2) collect samples in accordance with the sampling protocols from the vertical monitoring well and the stilling basin. The samples will be analyzed for TPH-d and TPH-g (EPA 8015B); total lead (EPA 6020); BTXE, MtBE and 1, 2-Dichloroethane (EPA 5030B/8260B); PAHs (EPA 8270C); Ethylene Dibromide (EPA 8011). The contractor will prepare

5090 0000
Ser N465/
08 JUL 2004

reports to document activities, including analytical results, wastes disposal, conclusions and recommendations after completion of sampling event.

Item 4. See Item 3.

Item 5. Excerpts from a 1949 study of tanks 14 and 16 are included as enclosure (1). FISC is currently planning to have another structural study on the Red Hill Tanks done. The Navy will provide a schedule to DOH as soon as available.

Item 6. FISC, DESC, and NAVPET are currently and voluntarily looking at current technology of leak detection systems which is currently available.

If there are any questions regarding this matter, or if more information is needed, please contact Mr. Darren Uchima at (808) 471-1171, extension 217.

Sincerely,

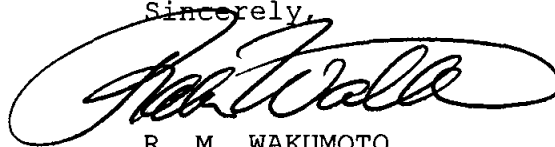

R. M. WAKUMOTO
Director
Regional Environmental Department
By direction of
Commander, Navy Region Hawaii

Enclosure: 1. Excerpts of Engineering Report on the results of survey of Navy Petroleum Facilities at Pearl Harbor dated May 12, 1949

LINDA LINGLE
GOVERNOR OF HAWAII



STATE OF HAWAII
DEPARTMENT OF HEALTH
P. O. BOX 3378
HONOLULU, HAWAII 96801-3378

CHIYOME L. FUKINO, M.D.
DIRECTOR OF HEALTH

In reply, please refer to:
EMD/SHWB

August 12, 2004

U08023RT

Mr. Darren Uchima
Navy Region Hawaii
Regional Environmental Department, N465
517 Russell Avenue, Suite 110
Pearl Harbor, Hawaii 96860-1884

Dear Mr. Uchima:

SUBJECT: Red Hill Tank Complex
Facility ID 9-102271 / Release IDs 990051, 010011, 020028

The Department of Health (DOH) has reviewed the following reports:

1. *Statement of Work – Long Term Monitoring/Remedial Action*, dated April 29, 2004, and prepared by Navy Region Hawaii;
2. *Statement of Work for A-E Services for Planning Documents and Related Technical Services*, dated May 4, 2004, and prepared Navy Region Hawaii;
3. Email update from Darren Uchima dated May 6, 2004;
4. Letter report dated July 8, 2004, and prepared by Navy Region Hawaii.

Regarding the *Statement of Work* dated April 29, 2004, DOH requests that fluoranthene be added to the list of chemical analyses to be performed on quarterly groundwater samples obtained from the facility.

Regarding the *Statement of Work* dated May 4, 2004, DOH has no objections. DOH notes that PACDIV is preparing a scope of work to conduct the comprehensive risk assessment for the Red Hill Tank Complex. As the comprehensive risk assessment is critical to our understanding of site conditions and contamination found at your facility, please complete it as soon as possible.

Mr. Darren Uchima
August 12, 2004
Page 2

Regarding the sampling of drinking water at the nearby Navy drinking water pump station, please coordinate sampling and monitoring activities with the proper state and federal agencies governing the drinking water supply. We are aware that the State's Safe Drinking Water Branch requires comprehensive drinking water sampling every 3 years. Due to the fact that 100 million to 200 million gallons of jet fuel and other petroleum products are continuously stored 500 feet away within the Red Hill Tank Complex, it is our recommendation that drinking water sampling analyses for specific petroleum contaminants be performed with a higher frequency than once every 3 years.

Regarding the letter report dated July 8, 2004, DOH notes the explanation from Navy Region Hawaii that formal quarterly progress reports (other than reports submitted during 1998 to present) have not been prepared. Please begin submitting quarterly progress reports to this office every 90 days as required by Hawaii Administrative Rules Chapter 11-281-80.1.

If you have any questions regarding this letter, please contact Mr. Richard Takaba of our Underground Storage Tank Section at (808) 586-4226.

Sincerely,



STEVEN Y.K. CHANG, P.E. CHIEF
Solid and Hazardous Waste Branch

c: Matt Small, U.S. EPA Region 9
Barbara Brooks, Hazard Evaluation and Emergency Response Office
Clarence Callahan, Hazard Evaluation and Emergency Response Office
William Wong, Safe Drinking Water Branch



DEPARTMENT OF THE NAVY

COMMANDER
NAVY REGION HAWAII
850 TICONDEROGA ST STE 110
PEARL HARBOR HI 96860-5101

5090 00520
Ser N465/
08 OCT 2004

CERTIFIED MAIL NO. 7002 3150 0003 9288 5751

Mr. Richard Takaba
Project Officer
Solid & Hazardous Waste Branch
Hawaii Department of Health
919 Ala Moana Boulevard Room 212
Honolulu HI 96814

SUBJECT: RED HILL TANK COMPLEX QUARTERLY PROGRESS REPORT
(OCTOBER 2004) FACILITY I.D. NO. 9-102271/RELEASE I. D.
NOS. 990051, 010011 AND 020028

Dear Mr. Takaba:

In response to the State of Hawaii Department of Health Letter, U08023RT, dated August 12, 2004, we are providing the following quarterly progress report as required.

Groundwater and Drinking Water Sampling

The Groundwater and Drinking Water Sampling contract was awarded on June 9, 2004. The scope of work includes the following:

1. Preparation of a sampling protocol for collecting samples from the vertical monitoring well (MW-V1D) and from the stilling basin at the PWC potable water infiltration tunnel at Red Hill.
2. Collecting of samples in accordance with the sampling protocol from the vertical monitoring well (MW-V1D) and the stilling basin at the PWC potable water infiltration tunnel at Red Hill. The samples will be analyzed for TPH-d and TPH-g (EPA 8015B); total lead (EPA 6020); BTXE, MtBE and 1, 2-Dichloroethane (EPA 5030B/8260B); PAHs (EPA 8270C); Ethylene Dibromide (EPA 8011). Fluoranthene will be sampled as part of PAHs. The contract covers 4 sampling events at 3 month intervals.

The draft health and safety plan and work plan is tentatively scheduled to be submitted to the Navy by the end of October 2004. Upon receipt of the draft plans, the Navy will forward to the State of Hawaii Department of Health Solid and Hazardous Waste Branch for review and comment as recommended.

Drinking water sampling and analyses for specific petroleum contaminants performed at a higher frequency than once every three years is currently being discussed with Public Works Center.

5090 00520
Ser N465/
08 OCT 2004

Risk Assessment

The Risk Assessment will be completed in two phases. The contract for the first phase was awarded on September 17, 2004. The scope of work includes the following:

1. Preparation of a work plan describing protocols for drilling activities, sample collection and analyses, geophysical surveys (phase 1 & 2) and IDW handling and disposal. The plan shall address protocols to insure the quality of all analytical data are consistent with the recommendations of the Department of Health. The plan shall describe the interrelationships of each activity relative to the ultimate goal of assessing the risk at the Red Hill water pumping station.
3. Prepare a health and safety plan for covering all field activities.
4. Install two (2) vertical monitoring wells within the lower access tunnel to serve as sentinel wells to monitor for contamination of the basal aquifer beneath the fuel tank facility. The construction of the well within the access tunnel shall not create a route for contamination to migrate from shallow basaltic formations to the basal aquifer. Measure groundwater gradient in the area beneath the tank farm to better evaluate the direction of groundwater flux through the area. Screen core samples for organic vapors. Collect and analyze up to four (4) core samples from each boring for chemicals analyses of suspected chemical contaminants (TPH GRO & DRO, BTXE, MTBE, PNAs, total lead, tetraethyl lead, fractional analyses for aliphatic and aromatic fractions).
5. Collect groundwater samples from the 2 new wells in the access tunnel and the existing vertical deep well (VID). Analyze the samples for chemical contaminants (TPH GRO & DRO, BTXE, MTBE, PNAs, total lead (filtered), tetraethyl lead, and fractional analyses).
6. Conduct pilot testing of high-resolution resistivity methodology to determine suitability of the method to characterize the geology at the project site. Prepare a report to document the results of the test. The report will be used to define the scope of the geophysical activities in Phase 2.
7. Develop a GIS three-dimensional spatial database incorporating data from existing data (drawings, logs, etc.), drilling activities and geophysical surveys.
8. Disposal of all investigative derived waste.

5090 00520
Ser N465/
08 OCT 2004

The contractor has begun his project management activities. Will be scheduling a meeting in Hawaii to discuss plan of action with various point of contacts in early November 2004. A meeting with Hawaii Department of Health risk assessment personnel will be scheduled by the end of November 2004. Risk Assessment activities are scheduled to commence by the end of January 2005.

Tank Inspections

Red Hill Tanks have been tentatively scheduled as follows:

FY2004 - Tanks 1 & 15 (Currently on-going)
FY2005 - Tanks 17 & 18
FY2006 - Tanks 11 & 20
FY2007 - Tanks 4 & 5
FY2008 - Tanks 2, 3 & 19

If there are any questions regarding this matter, or if more information is needed, please contact Mr. Darren Uchima at (808) 471-1171, extension 217. The next quarterly progress report will be provided in January 2005.

Sincerely,

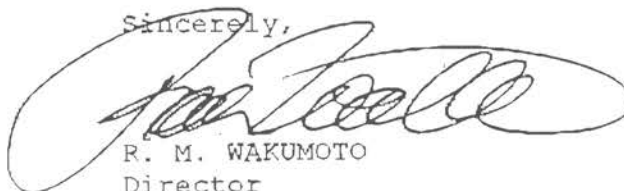

R. M. WAKUMOTO
Director
Regional Environmental Department
By direction of
Commander, Navy Region Hawaii



DEPARTMENT OF THE NAVY

COMMANDER
NAVY REGION HAWAII
850 TICONDEROGA ST STE 110
PEARL HARBOR HI 96860-5101

5090
Ser N465/

00013

13 JAN 2005

CERTIFIED MAIL NO. 7002 3150 0003 9288 6284

Mr. Richard Takaba
Project Officer
Solid & Hazardous Waste Branch
Hawaii Department of Health
919 Ala Moana Boulevard Room 212
Honolulu HI 96814

SUBJECT: RED HILL TANK COMPLEX QUARTERLY PROGRESS REPORT (JANUARY 2005)
FACILITY I.D. NO. 9-102271/RELEASE I.D. NOS. 990051, 010011 &
020028

Dear Mr. Takaba:

In response to the State of Hawaii Department of Health Letter, U08023RT, dated August 12, 2004, we are providing the following quarterly progress report as required.

Groundwater and Drinking Water Sampling

The "Draft Work Plan and Field Sampling Plan for Groundwater Sampling of the Red Hill Fuel Storage Facility" is submitted in enclosure (1). Please review and comment on the "Draft Work Plan and Field Sampling Plan". If no comments are received by the Navy from the DOH by the end of January 2005, the Navy will proceed as planned.

The "Draft Health and Safety Plan for Groundwater Sampling of the Red Hill Fuel Storage Facility" was submitted to the Navy Region Hawaii Health and Safety Department for review and comment on January 7, 2005.

Drinking water sampling and analyses for specific petroleum contaminants performed at a higher frequency than once every three years is currently being discussed with Public Works Center.

Risk Assessment

A meeting was held on November 8, 2004, with the contractors to discuss plan of action. During the meeting the Navy and contractor agreed to install a vertical monitoring well in the middle of the tank farm to determine if a contaminant plume actually exists beneath the fuel farm. This would increase resolution of the geophysical survey and would provide additional information for the geologic characterization for modeling purposes of the area from the tank bottoms to the groundwater (approximately 100 foot depth). The well would be installed during Phase 1 of the project.

5090 00013
Ser N465/
13 JAN 2005

We will be using a FeFlow model to simulate contaminant transport of light non-aqueous phase liquid and contaminants of concern. The FeFlow model for Red Hill will be developed by the same contractor who just completed the development of the groundwater model of Oahu for the Honolulu Board of Water Supply to evaluate saltwater intrusion of the Oahu basal aquifer.

Tank Inspections

Red Hill Tanks have been tentatively scheduled as follows:

FY2004 - Tanks 1 & 15 (Currently on-going)
FY2005 - Tanks 17 & 18
FY2006 - Tanks 11 & 20
FY2007 - Tanks 4 & 5
FY2008 - Tanks 2, 3 & 19

If there are any questions regarding this matter, or if more information is needed, please contact Mr. Darren Uchima at (808) 471-1171, extension 217. The next quarterly progress report will be provided in April 2005.

Sincerely,

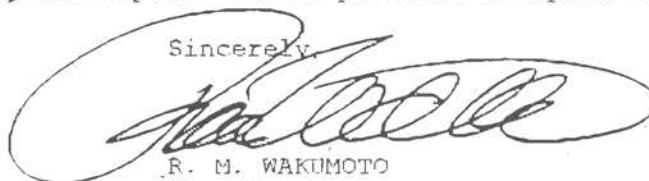

R. M. WAKIMOTO
Director
Regional Environmental Department
By direction of
Commander, Navy Region Hawaii

Enclosure: 1. Draft Work Plan and Field Sampling Plan for Groundwater Sampling at the Red Hill Fuel Storage Facility, Hawaii dated December 2004



DEPARTMENT OF THE NAVY

COMMANDER
NAVY REGION HAWAII
850 TICONDEROGA ST STE 110
PEARL HARBOR HI 98860-5101

5090 00106
Ser N45/
13 APR 2005

CERTIFIED MAIL NO. 7002 3150 0003 9288 7380

Mr. Richard Takaba
Project Officer
Solid & Hazardous Waste Branch
Hawaii Department of Health
919 Ala Moana Boulevard Room 212
Honolulu HI 96814

SUBJECT: RED HILL TANK COMPLEX QUARTERLY PROGRESS REPORT
(APRIL 2005) FACILITY I.D. NO. 9-102271/RELEASE I.D. NOS.
990051, 010011 AND 020028

Dear Mr. Takaba:

In response to the State of Hawaii Department of Health (DOH) Letter, U08023RT, dated August 12, 2004, we are providing the following quarterly progress report as required.

Groundwater and Drinking Water Sampling

DOH Letter, U03002RT, dated March 1, 2005, provided comments on the "Draft Work Plan and Field Sampling Plan for Groundwater Sampling of the Red Hill Fuel Storage Facility".

The Navy has confirmed that sample analyses of poly-aromatic hydrocarbons (PAHs) are specified in the contract. PAHs included are benzo(a)pyrene, acenaphthene, fluoranthene, and naphthalene, with minimum detection limits lower than DOH Tier 1 action levels for "drinking water threatened".

Also, the Navy will conduct quarterly groundwater monitoring for the existing sentinel well in the facility and the two additional sentinel wells proposed in the work plan.

The Navy Region Hawaii Health and Safety Department approved the "Draft Work Plan and Field Sampling Plan for Groundwater Sampling of the Red Hill Fuel Storage Facility" for final.

Risk Assessment

The Navy and contractor has agreed to install two (2) vertical monitoring wells within the lower access tunnel to serve as sentinel wells to monitor for contamination of the basal aquifer beneath the

5090 00106
Ser N45/
13 APR 2005

fuel tank facility. The contractor will measure groundwater gradient in the area beneath the tank farm to better evaluate the direction of groundwater flux through the area.

The Navy and contractor has also agreed to install a groundwater monitoring well upgradient of the Red Hill Facility to establish background conditions, calibration point for the groundwater model, and to meet the requirements of the Monitored Attenuation Policy of the State of Hawaii DOH and the EPA.

The contractor will conduct pilot of soil vapor monitoring to evaluate presence of volatile organic compounds in the basalt flows under the USTs. Evaluate potential to use the soil vapor monitoring system as temporal monitoring devices to assist in detecting releases from the USTs.

The contractor will develop a GIS three dimensional spatial database incorporating data from existing data (drawings, logs, etc.), and drilling activities.

Tank Inspections

Red Hill Tanks have been tentatively scheduled as follows:

FY2005 - Tanks 1, 6, 15 & 16 (Currently on-going)
FY2006 - Tanks 11, 17, 18 & 20
FY2007 - Tanks 4 & 5
FY2008 - Tanks 2, 3 & 19

If there are any questions regarding this matter, or if more information is needed, please contact Mr. Darren Uchima at (808) 471-1171, extension 217. The next quarterly progress report will be provided in July 2005.

Sincerely,

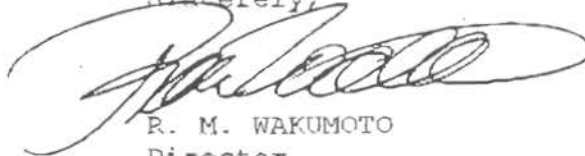

R. M. WAKUMOTO
Director
Regional Environmental Department
By direction of
Commander, Navy Region Hawaii



DEPARTMENT OF THE NAVY

COMMANDER
NAVY REGION HAWAII
850 TICONDEROGA ST STE 110
PEARL HARBOR HI 96860-5101

5090
Ser N45/ 00125
04 MAY 2005

CERTIFIED MAIL NO. 7002 3150 0003 9288 5027

Mr. Richard Takaba
Underground Storage Tank Section
Solid & Hazardous Waste Branch
Environmental Management Division
State of Hawaii Department of Health
919 Ala Moana Boulevard Room 212
Honolulu HI 96814

SUBJECT: RED HILL TANK COMPLEX
FACILITY I.D. NO. 9-102271/RELEASE I.D. NOS. 990051,
010011 AND 020028

Dear Mr. Takaba:

We are submitting the Draft Work Plan, Red Hill Bulk Fuel Storage Facility Site Investigation and Comprehensive Risk Assessment dated April 2005 as requested.

Please review and provide any comments by May 20, 2005.

If there are any questions regarding this matter, or if more information is needed, please contact Mr. Darren Uchima at (808) 471-1171, extension 217.

Sincerely,

R. M. WAKUMOTO
Director
Regional Environmental Department
By direction of
Commander, Navy Region Hawaii

Enclosure: 1. Draft Work Plan, Red Hill Bulk Fuel Storage Facility Site Investigation and Comprehensive Risk Assessment dated April 2005 (3 copies)

RECEIVED BY

DATE



DEPARTMENT OF THE NAVY

COMMANDER
NAVY REGION HAWAII
850 TICONDEROGA ST STE 110
PEARL HARBOR HI 96860-5101

5090 00199
Ser N45/
12 JUL 2005

Mr. Richard Takaba
Project Officer
Solid & Hazardous Waste Branch
Environmental Management Division
Hawaii Department of Health
919 Ala Moana Boulevard Room 212
Honolulu HI 96814

SUBJECT: RED HILL TANK COMPLEX QUARTERLY PROGRESS REPORT
(JULY 2005) FACILITY I.D. NO. 9-102271/RELEASE I.D.
NOS. 990051, 010011 AND 020028

Dear Mr. Takaba:

In response to the State of Hawaii Department of Health (DOH) Letter, U08023RT, dated August 12, 2004, Navy Region Hawaii is providing the following quarterly progress report as required.

Groundwater and Drinking Water Sampling

The First Quarter 2005 Groundwater Sampling Report of the Red Hill Fuel Storage Facility taken February 17, 2005, was provided to Department of Health on June 1, 2005.

The Second Quarter 2005 Groundwater Sampling Event for the Red Hill Fuel Storage Facility was conducted on June 28, 2005. The Second Quarter 2005 Groundwater Sampling Report will be provided to the DOH upon receipt by Navy Region Hawaii.

Risk Assessment

Navy Region Hawaii provided DOH the Final Work Plan and Health and Safety Plan for the Red Hill Bulk Fuel Storage Facility on June 7, 2005.

Tank Inspections

Red Hill Tank Inspections have been tentatively scheduled as follows:

FY2005 - Tanks 1, 6, 15 & 16 (Currently on-going)
FY2006 - Tanks 11, 17, 18 & 20
FY2007 - Tanks 4 & 5
FY2008 - Tanks 2, 3 & 19

5090
Ser N45/ CG199
12 JUN 2005

If there are any questions regarding this matter, or if more information is needed, please contact Mr. Darren Uchima at (808) 471-1171, extension 217. The next quarterly progress report will be provided in October 2005.

Sincerely,

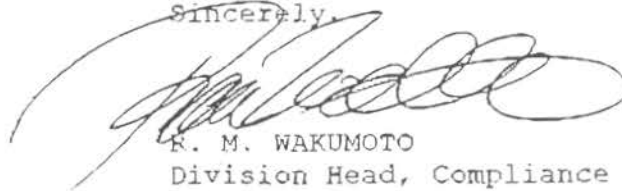

R. M. WAKUMOTO
Division Head, Compliance
Regional Environmental Department
By direction of
Commander, Navy Region Hawaii

LINDA LINGLE
GOVERNOR OF HAWAII



COPY RECEIVED SEP 01 2005

CHIYOME L. FUKINO, M.D.
DIRECTOR OF HEALTH

STATE OF HAWAII
DEPARTMENT OF HEALTH
P. O. BOX 3378
HONOLULU, HAWAII 96801-3378

In reply, please refer to:
EMD/SHWB

August 25, 2005

U08045RT

Mr. Darren Uchima
Navy Region Hawaii
Regional Environmental Department, N465
517 Russell Avenue, Suite 110
Pearl Harbor, Hawaii 96860-1884

Dear Mr. Uchima:

SUBJECT: Red Hill Tank Complex
Facility ID 9-102271 / Release IDs 990051, 010011 & 020028

The Department of Health (DOH) has reviewed the report, "First Quarter 2005 Groundwater Sampling," dated April 2005, and prepared by NAVFAC Pacific. Please note the document has been placed with the public record.

DOH notes that total dissolved lead was detected at concentrations higher than DOH Tier 1 action levels for drinking water threatened in monitoring well MW-VD1. Analytical results of 12 parts per billion (ppb) were found vs. the DOH action level of 5.6 ppb. All other analyses for BTEX and PAHs were non-detectable or well below DOH Tier 1 action levels. Please continue quarterly groundwater monitoring of the existing monitoring wells in the facilities with progress reports sent to this office every 90 days.

DOH has also received the report titled, "Red Hill Bulk Fuel Storage Facility Work Plan," dated June 2005. The report will be reviewed by a DOH risk assessor for comment.

If you have any questions regarding this letter, please contact Mr. Richard Takaba of our Underground Storage Tank Section at (808) 586-4226.

Sincerely,

STEVEN Y.K. CHANG, P.E., CHIEF
Solid and Hazardous Waste Branch



DEPARTMENT OF THE NAVY

COMMANDER
NAVY REGION HAWAII
850 TICONDEROGA ST STE 110
PEARL HARBOR HI 96860-5101

5090 00266
Ser N45/
07 SEP 2005

Mr. Richard Takaba
Underground Storage Tank Section
Solid & Hazardous Waste Branch
Environmental Management Division
State of Hawaii Department of Health
919 Ala Moana Boulevard Room 212
Honolulu HI 96814

SUBJECT: RED HILL TANK COMPLEX
SECOND QUARTER 2005 GROUNDWATER SAMPLING REPORT
FACILITY I.D. NO. 9-102271/RELEASE I.D. NOS. 990051,
010011 AND 020028

Dear Mr. Takaba:

We are submitting the Second Quarter 2005 Groundwater Sampling Report of the Red Hill Fuel Storage Facility dated August 2005 as required.

Our next groundwater sampling is scheduled for September 2005. The Navy will provide the Third Quarter 2005 Groundwater Sampling Report to the Department of Health upon receipt.

If there are any questions regarding this matter, or if more information is needed, please contact Ms. Raelynn Della Sala at (808) 473-4137, extension 229.

Sincerely,

C. K. YOKOTA
Director
Regional Environmental Department
By direction of
Commander, Navy Region Hawaii

Enclosure: 1. Second Quarter 2005 Groundwater Sampling Red Hill Fuel Storage Facility, Hawaii dated August 2005 prepared by Dawson Group, Inc. Contract Number N62742-01-D-1806, CTO 0013



DEPARTMENT OF THE NAVY

COMMANDER
NAVY REGION HAWAII
850 TICONDEROGA ST STE 110
PEARL HARBOR HI 96860-5101

5090 00300
Ser N45/
12 OCT 2005

Mr. Richard Takaba
Project Officer
Solid & Hazardous Waste Branch
Environmental Management Division
State of Hawaii Department of Health
919 Ala Moana Boulevard Room 212
Honolulu HI 96814

SUBJECT: RED HILL TANK COMPLEX QUARTERLY PROGRESS REPORT
(OCTOBER 2005) FACILITY I. D. NO. 9-102271/RELEASE I. D.
NOS. 990051, 010011 AND 020028

Dear Mr. Takaba:

In response to the State of Hawaii Department of Health (DOH) Letter, U08023RT, dated August 12, 2004, Navy Region Hawaii is providing the following quarterly progress report as required.

Groundwater and Drinking Water Sampling

The Second Quarter 2005 Groundwater Sampling Report of the Red Hill Fuel Storage Facility dated August 2005 was provided to the DOH on September 7, 2005.

The Third Quarter 2005 Groundwater Sampling Event for the Red Hill Fuel Storage Facility was conducted on September 8, 2005. The Third Quarter 2005 Groundwater Sampling Report will be provided to the DOH upon receipt by Navy Region Hawaii.

Risk Assessment

No change from previous Quarterly Progress Report (July 2005).

Navy Region Hawaii provided DOH the Final Work Plan and Health and Safety Plan for the Red Hill Bulk Fuel Storage Facility on June 7, 2005.

Tank Inspections

Red Hill Tank Inspections have been tentatively scheduled as follows:

FY2005/2006 - Tanks 1, 6, 15 & 16 (Currently on-going)
FY2007 - Tanks 11, 17, 18 & 20
FY2008 - Tanks 4 & 5
FY2009 - Tanks 2, 3 & 19

5090 00300
Ser N45/
12 OCT 2005

If there are any questions regarding this matter, or if more information is needed, please contact Ms. Raelynn Della Sala at 473-4137, extension 229. The next quarterly progress report will be provided in January 2006.

Sincerely,

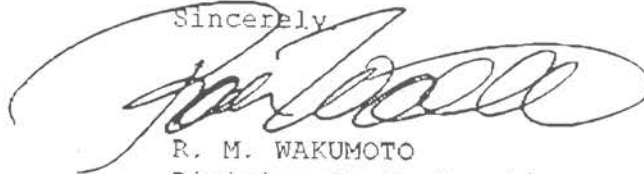

R. M. WAKUMOTO
Division Head, Compliance
Regional Environmental Department
By direction of
Commander, Navy Region Hawaii



DEPARTMENT OF THE NAVY

COMMANDER
NAVY REGION HAWAII
850 TICONDEROGA ST STE 110
PEARL HARBOR HI 96860-5101

5090 00334
Ser. N45/
28 NOV 2005

Mr. Richard Takaba
Underground Storage Tank Section
Solid & Hazardous Waste Branch
Environmental Management Division
State of Hawaii Department of Health
919 Ala Moana Boulevard Room 212
Honolulu HI 96814

SUBJECT: RED HILL TANK COMPLEX
THIRD QUARTER 2005 GROUNDWATER SAMPLING REPORT
FACILITY I.D. NO. 9-102271/RELEASE I.D. NOS. 990051, 010011 AND
020028

Dear Mr. Takaba:

We are submitting the Third Quarter 2005 Groundwater Sampling Report of the Red Hill Fuel Storage Facility dated November 2005 as required.

Our next groundwater sampling is scheduled for December 2005. The Navy will provide the Fourth Quarter 2005 Groundwater Sampling Report to the Department of Health upon receipt.

If there are any questions regarding this matter, or if more information is needed, please contact Ms. Raelynn Della Sala at (808) 473-4137, extension 229.

Sincerely,

A handwritten signature in black ink, appearing to read "R. M. Wakumoto", written over a large, stylized, circular flourish.

R. M. WAKUMOTO
Division Head, Compliance
Regional Environmental Department
By direction of
Commander, Navy Region Hawaii

Enclosure: 1. Third Quarter 2005 Groundwater Sampling Red Hill Fuel Storage Facility, Hawaii dated November 2005 prepared by Dawson Group, Inc. Contract Number N62742-01-D-1806, CTO 0013



DEPARTMENT OF THE NAVY

COMMANDER
NAVY REGION HAWAII
850 TICONDEROGA ST STE 110
PEARL HARBOR HI 96860-5101

5090 00012
Ser N45/
13 JAN 2006

Mr. Richard Takaba
Project Officer
Solid and Hazardous Waste Branch
Hawaii Department of Health
919 Ala Moana Boulevard, Room 212
Honolulu HI 96814

SUBJECT: RED HILL TANK COMPLEX QUARTERLY PROGRESS REPORT (JANUARY 2006)
FACILITY I.D. NO. 9-102271/RELEASE I.D. NOS. 990051, 010011
AND 020028

Dear Mr. Takaba:

In response to the State of Hawaii Department of Health (DOH) Letter, U08023RT, dated August 12, 2004, Navy Region Hawaii is providing the following quarterly progress report as required.

Groundwater and Drinking Water Sampling

The Third Quarter 2005 Groundwater Sampling Report of the Red Hill Fuel Storage Facility dated November 2005 was provided to the DOH on November 28, 2005.

The Fourth Quarter 2005 Groundwater Sampling Event for the Red Hill Fuel Storage Facility was conducted on December 6, 2005. The Fourth Quarter 2005 Groundwater Sampling Report will be provided to the DOH upon receipt by Navy Region Hawaii.

On January 10, 2006, a meeting was held between DOH, the Navy, and The Environmental Company Inc. (TEC) to review the scope of the project and introduce the second phase of the project. During the meeting, analytical data collected by TEC and Dawson Group, Inc. (Dawson) were presented. The data collected by Dawson was previously provided to DOH. The data collected by TEC are being submitted in enclosures (1) through (9).

Risk Assessment

No change from previous Quarterly Progress Reports (July, October 2005).

Navy Region Hawaii provided DOH the Final Work Plan and Health and Safety Plan for the Red Hill Bulk Fuel Storage Facility on June 7, 2005.

Tank Inspections

No change from previous Quarterly Progress Reports (July, October 2005).

5090
Ser N45/ 00012
13 JAN 2006

Red Hill Tank Inspections have been tentatively scheduled as follows:

FY2005 - Tanks 1, 6, 15 & 16 (Currently on-going)
FY2006 - Tanks 11, 17, 18 & 20
FY2007 - Tanks 4 & 5
FY2008 - Tanks 2, 3 & 19

If there are any questions regarding this matter, or if more information is needed, please contact Ms. Raelynn Della Sala at (808) 473-4137, extension 229. The next quarterly progress report will be provided in April 2006.

Sincerely,

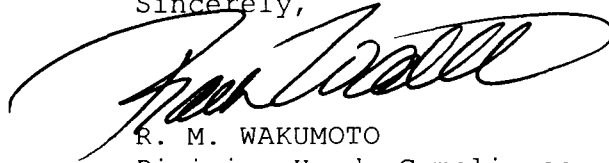

R. M. WAKUMOTO
Division Head, Compliance
Regional Environmental Department
By direction of
Commander, Navy Region Hawaii

- Enclosures:
1. Accutest Technical Report, Accutest Job Number F32936, Sampling Date 06/28/05 (30 pages)
 2. Accutest Preliminary Data, Accutest Job Number F32936, Sampling Date 06/28/05 (9 pages)
 3. Accutest Preliminary Data, Accutest Job Number F33091, Sampling Date 07/05/05 (13 pages)
 4. Accutest Preliminary Data, Accutest Job Number F33228, Sampling Date 07/12/05 (13 pages)
 5. Accutest Preliminary Data, Accutest Job Number F35042, Sampling Date 09/19/05 (7 pages)
 6. Accutest Technical Report, Accutest Job Number F35058, Sampling Date 09/19/05 (39 pages)
 7. Accutest Technical Report, Accutest Job Number F35102, Sampling Date 09/19/05 (89 pages)
 8. Accutest Preliminary Data, Accutest Job Number F35102, Sampling Date 09/19/05 (7 pages)
 9. Accutest Technical Report, Accutest Job Number F35142, Sampling Date 09/20/05 (319 pages)



DEPARTMENT OF THE NAVY

COMMANDER
NAVY REGION HAWAII
850 TICONDEROGA ST STE 110
PEARL HARBOR HI 96860-5101

5090 00023
Ser N45/
25 JAN 2006

CERTIFIED MAIL NO. 7004 1350 0001 3926 4995

Mr. Richard Takaba
Underground Storage Tank Section
Solid & Hazardous Waste Branch
Environmental Management Division
State of Hawaii Department of Health
919 Ala Moana Boulevard Room 212
Honolulu HI 96814

SUBJECT: RED HILL TANK COMPLEX
SEPTEMBER 2005 GROUNDWATER SAMPLING RESULTS
FACILITY I.D. NO. 9-102271/RELEASE I.D. NOS. 990051, 010011& 020028

Dear Mr. Takaba:

We are submitting a summary table of analytical results for groundwater samples collected by The Environmental Company (TEC) Inc. at the Red Hill Fuel Storage Facility in September 2005. The laboratory data reports for the groundwater samples were submitted with the Quarterly Progress Report on January 13, 2006, under Navy letter 5090 Ser N45/00012.

If there are any questions regarding this matter, or if more information is needed, please contact Ms. Raelynn Della Sala at (808) 473-4137, extension 229.

Sincerely,

R. M. WAKUMOTO
Division Head, Compliance
Regional Environmental Department
By direction of
Commander, Navy Region Hawaii

Enclosure: 1. Table A1-2. Summary of Analytical Program for Groundwater Samples, Red Hill Bulk Fuel Storage Facility, Pearl Harbor, Hawaii of January 20, 2006

**Table A1-2. Summary of Analytical Program for Groundwater Samples
Red Hill Bulk Fuel Storage Facility
Pearl Harbor, Hawaii**

Client Sample ID:		RHMW01W01	RHMW02Q01	RHMW02W01	RHMW03W01	RHMW04W01	RHMW2254W01	TRIP BLANK	EAL	EAL	EAL
Lab Sample ID:		F35142-1	F35142-4	F35142-2	F35142-3	F35142-5, et. al.	F35142-6	F35142-7	Drinking Water	Groundwater	Groundwater to Indoor Air
Date Sampled:		9/20/2005	9/20/2005	9/20/2005	9/21/2005	9/19/2005	9/19/2005	9/20/2005	Final Action Level	Final Ceiling Level	Low/Moderate Permeability
GC/MS Volatiles											
Benzene	ug/l	0.50 U	2.5 U	2.5 U	0.50 U	0.50 U	0.50 U	0.50 U	5	170	5653.75
Ethylbenzene	ug/l	0.50 U	2.5 U	2.5 U	0.50 U	0.50 U	0.50 U	0.50 U	700	30	169000
Methyl Tert Butyl Ether	ug/l	0.50 U	2.5 U	2.5 U	0.50 U	0.50 U	0.50 U	0.50 U	10.59	5	37699.83
Toluene	ug/l	0.50 U	2.5 U	2.5 U	0.50 U	0.50 U	0.50 U	0.50 U	1000	40	526000
Trichloroethylene	ug/l	0.50 U	2.5 U	8.2	0.50 U	0.50 U	0.50 U	0.50 U	5	170	310000
m,p-Xylene	ug/l	0.50 U	2.5 U	2.5 U	0.50 U	0.50 U	0.50 U	0.50 U	10000	20	161000
o-Xylene	ug/l	0.50 U	2.5 U	2.5 U	0.50 U	0.50 U	0.50 U	0.50 U	10000	20	161000
GC/MS Semi-volatiles											
Acenaphthene	ug/l	NA	0.52 U	0.52 U	0.48 U	0.57 U	NA	NA	365	20	4240
Acenaphthylene	ug/l	NA	0.52 U	0.52 U	0.48 U	0.57 U	NA	NA	243.3	1965	(use soil gas)
Anthracene	ug/l	NA	0.52 U	0.52 U	0.48 U	0.57 U	NA	NA	1825	21.7	43.4
Benzo(a)anthracene	ug/l	NA	0.071 J	0.052 U	0.048 U	0.057 U	NA	NA	0.09	5	NA
Benzo(a)pyrene	ug/l	NA	0.10 U	0.10 U	0.096 U	0.11 U	NA	NA	0.2	1.9	NA
Benzo(b)fluoranthene	ug/l	NA	0.069 J	0.052 U	0.048 U	0.057 U	NA	NA	0.09	7	NA
Benzo(g,h,i)perylene	ug/l	NA	0.10 U	0.10 U	0.096 U	0.11 U	NA	NA	1460	0.013	NA
Benzo(k)fluoranthene	ug/l	NA	0.10 U	0.10 U	0.096 U	0.11 U	NA	NA	0.92	0.4	NA
Chrysene	ug/l	NA	0.10 U	0.10 U	0.096 U	0.11 U	NA	NA	9.21	0.8	NA
Dibenzo(a,h)anthracene	ug/l	NA	0.052 U	0.052 U	0.048 U	0.057 U	NA	NA	0.01	0.25	NA
Fluoranthene	ug/l	NA	0.26 U	0.26 U	0.24 U	0.28 U	NA	NA	1460	132.5	NA
Fluorene	ug/l	NA	0.26 U	0.26 U	0.24 U	0.28 U	NA	NA	243.33	950	1900
Indeno(1,2,3-cd)pyrene	ug/l	NA	0.052 U	0.052 U	0.048 U	0.057 U	NA	NA	NA	NA	NA
1-Methylnaphthalene	ug/l	NA	102	104	0.24 U	0.28 U	NA	NA	NA	NA	NA
2-Methylnaphthalene	ug/l	NA	87.2	88.5	0.24 U	0.28 U	NA	NA	243.33	10	26000
Naphthalene	ug/l	NA	123	120	0.24 U	0.28 U	NA	NA	6.22	21	31000
Phenanthrene	ug/l	NA	0.52 U	0.52 U	0.48 U	0.57 U	NA	NA	243.33	408	(use soil gas)
Pyrene	ug/l	NA	0.26 U	0.26 U	0.24 U	0.28 U	NA	NA	182.5	67.5	135
SW846 8015											
TPH-GRO (C6-C10)	mg/l	NA	0.050 U	0.050 U	0.050 U	0.050 U			0.1	0.1	(use soil gas)
TPH-DRO (C10-C28)	mg/l	NA	2.50	2.66	0.162 J	0.338			0.1	0.1	

123 Result is greater than the HDOH Environmental Action Level (HDOH, 2005)

NA - Not Applicable



DEPARTMENT OF THE NAVY

COMMANDER
NAVY REGION HAWAII
850 TICONDEROGA ST STE 110
PEARL HARBOR HI 96860-5101

5090
Ser N45/ 00025
25 JAN 2006

Mr. Richard Takaba
Underground Storage Tank Section
Solid & Hazardous Waste Branch
Environmental Management Division
State of Hawaii Department of Health
919 Ala Moana Boulevard Room 212
Honolulu HI 96814

SUBJECT: RED HILL TANK COMPLEX
DRAFT ADDENDUM PLANNING DOCUMENTS
FACILITY I.D. NO. 9-102271/RELEASE I.D. NOS. 990051,
010011 AND 020028

Dear Mr. Takaba:

We are submitting the "Red Hill Bulk Fuel Storage Facility Draft - Addendum Planning Documents" prepared by The Environmental Company (TEC) Inc.

If there are any questions regarding this matter, or if more information is needed, please contact Ms. Raelynn Della Sala at (808) 473-4137, extension 229.

Sincerely,

A handwritten signature in black ink, appearing to read "R. M. Wakumoto", written over a large, stylized flourish.

R. M. WAKUMOTO
Division Head, Compliance
Regional Environmental Department
By direction of
Commander, Navy Region Hawaii

Enclosure: 1. Red Hill Bulk Fuel Storage Facility Draft -
Addendum Planning Documents Pearl Harbor, Hawaii
prepared by TEC Inc., Contract No. N62742-02-D-
1802, CTO 007, of January 2006



DEPARTMENT OF THE NAVY

COMMANDER
NAVY REGION HAWAII
850 TICONDEROGA ST STE 110
PEARL HARBOR HI 96860-5101

5090 00112
Ser N45/
13 APR 2006

CERTIFIED MAIL NO. 7004 1350 0001 3925 8246

Mr. Richard Takaba
Project Officer
Solid & Hazardous Waste Branch
Hawaii Department of Health
919 Ala Moana Boulevard Room 212
Honolulu HI 96814

SUBJECT: RED HILL TANK COMPLEX QUARTERLY PROGRESS REPORT (APRIL 2006)
FACILITY ID NO. 9-102271/RELEASE ID NOS. 990051, 010011 AND
020028

Dear Mr. Takaba:

In response to the State of Hawaii Department of Health (DOH) Letter, U08023RT, of August 12, 2004, Navy Region Hawaii is providing the following quarterly progress report as required.

Groundwater and Drinking Water Sampling

A summary table of preliminary analytical results for groundwater samples collected by The Environmental Company (TEC) Inc. in September 2005 was submitted to the DOH on January 25, 2006. The results have been validated and are presented in enclosure (1). The sample locations are shown on the site plan map, which is provided in enclosure (2). Results greater than the DOH Environmental Action Levels (EALs) for drinking water are highlighted and include the following chemicals:

- Trichloroethylene in RHMW02
- Naphthalene in RHMW02
- Total petroleum hydrocarbons (middle distillates, C10-C28) in RHMW02, RHMW03, and RHMW04

Although lead was detected in RHMW01 above the DOH EAL, the sample was not filtered. Filtered lead samples were collected from RHMW01 by Dawson Group, Inc. (Dawson) during the same period, and the results were below the DOH EAL for drinking water.

The Fourth Quarter 2005 Groundwater Sampling Report of the Red Hill Fuel Storage Facility dated February 2006 and prepared by Dawson was provided to the DOH on March 31, 2006.

5090 C0112
Ser N45/
13 APR 2006Risk Assessment

Navy Region Hawaii provided DOH the Red Hill Bulk Fuel Storage Facility Draft - Addendum Planning Documents prepared by TEC Inc. on January 25, 2006.

Tank Inspections

Red Hill Tank Inspections have been tentatively scheduled as follows:

FY2006 - Tanks 1, 6, 15 & 16 (currently on-going)
FY2007 - Tanks 11, 17, 18 & 20
FY2008 - Tanks 4 & 5
FY2009 - Tanks 2, 3 & 19

If there are any questions regarding this matter, or if more information is needed, please contact Ms. Raelynn Della Sala at (808) 473-4137, extension 229. The next quarterly progress report will be provided in July 2006.

Sincerely,

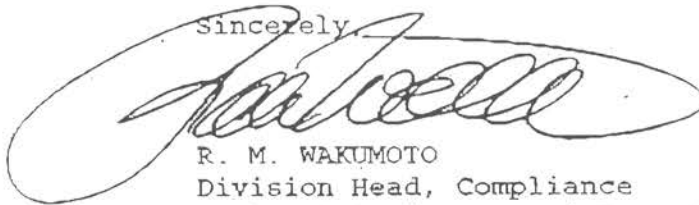

R. M. WAKUMOTO
Division Head, Compliance
Regional Environmental Department
By direction of
Commander, Navy Region Hawaii

- Enclosures: 1. Table 1, Summary of Groundwater Sampling Results, Red Hill Bulk Fuel Storage Facility, Pearl Harbor, Hawaii
2. Figure 1, Site Plan Map, Red Hill Bulk Fuel Storage Facility, Fleet Industrial Supply Center

Table 1. Summary of Groundwater Sampling Results
Red HBI Bulk Fuel Storage Facility
Pearl Harbor, Hawaii

Client Sample ID: Lab Sample ID: Date Sampled:	RHMW01W01 F35142-1 9/20/2005	RHMW02W01 F35142-4 9/20/2005	RHMW03W01 F35142-2 9/20/2005	RHMW04W01 F35142-3 9/21/2005	RHMW05W01 F35142-5 9/19/2005	RHMW2224W01 F35142-4 9/19/2005	TRIP BLANK F35142-7 9/20/2005	EAL Drinking Water Final Action Level	EAL Groundwater to Indoor Air Low/Moderate Permeability
GC/MS Volatiles									
Benzene	0.50 U	2.5 U	2.5 U	0.50 U	0.50 U	0.50 U	0.50 U	5	5653.75
Ethylbenzene	0.50 U	2.5 U	2.5 U	0.50 U	0.50 U	0.50 U	0.50 U	700	169000
Methyl Tert Butyl Ether	0.50 U	2.5 U	2.5 U	0.50 U	0.50 U	0.50 U	0.50 U	10.59	37699.83
Toluene	0.50 U	2.5 U	2.5 U	0.50 U	0.50 U	0.50 U	0.50 U	1000	526000
Trichloroethylene	0.50 U	2.5 U	2.5 U	0.50 U	0.50 U	0.50 U	0.50 U	5	310000
m,p-Xylene	0.50 U	2.5 U	2.5 U	0.50 U	0.50 U	0.50 U	0.50 U	10000	161000
o-Xylene	0.50 U	2.5 U	2.5 U	0.50 U	0.50 U	0.50 U	0.50 U	10000	161000
GC/MS Semi-volatiles									
Acenaphthene	NA	0.52 U	0.52 U	0.48 U	0.57 U	NA	NA	365	4240
Acenaphthylene	NA	0.52 U	0.52 U	0.48 U	0.57 U	NA	NA	243.3	(use soil gas)
Anthracene	NA	0.52 U	0.52 U	0.48 U	0.57 U	NA	NA	182.5	43.4
Benzo(a)anthracene	NA	0.071 U	0.052 U	0.048 U	0.057 U	NA	NA	0.09	
Benzo(a)pyrene	NA	0.10 U	0.10 U	0.096 U	0.11 U	NA	NA	0.2	
Benzo(b)fluoranthene	NA	0.069 U	0.052 U	0.048 U	0.057 U	NA	NA	0.09	
Benzo(k)fluoranthene	NA	0.10 U	0.10 U	0.096 U	0.11 U	NA	NA	1460	
Benzo(e)fluoranthene	NA	0.10 U	0.10 U	0.096 U	0.11 U	NA	NA	0.92	
Chrysene	NA	0.10 U	0.10 U	0.096 U	0.11 U	NA	NA	9.21	
Dibenz(a,h)anthracene	NA	0.052 U	0.052 U	0.048 U	0.057 U	NA	NA	0.01	
Fluoranthene	NA	0.26 U	0.26 U	0.24 U	0.28 U	NA	NA	1460	
Fluorene	NA	0.26 U	0.26 U	0.24 U	0.28 U	NA	NA	243.3	1900
Indeno(1,2,3-cd)pyrene	NA	0.052 U	0.052 U	0.048 U	0.057 U	NA	NA	NA	
1-Methylanthracene	NA	102	104	0.24 U	0.28 U	NA	NA	NA	
2-Methylanthracene	NA	37.2	38.5	0.24 U	0.28 U	NA	NA	243.3	26000
Naphthalene	NA	0.52 U	0.52 U	0.48 U	0.57 U	NA	NA	6.22	31000
Phenanthrene	NA	0.52 U	0.52 U	0.48 U	0.57 U	NA	NA	243.3	(use soil gas)
Pyrene	NA	0.26 U	0.26 U	0.24 U	0.28 U	NA	NA	182.5	135
SW846 8015									
TPH-GRO (C6-C10)	NA	0.050 U	0.050 U	0.050 U	0.050 U	NA	NA	0.1	(use soil gas)
TPH-GRO (C10-C28)	NA	0.050 U	0.050 U	0.050 U	0.050 U	NA	NA	0.1	
MLADEP									
EPA (C11-C22)	216 J	736	746 J	190 U	230 U	220 U	NA	NA	
EPA (C19-C16)	262 J	274 J	210 U	190 U	230 U	220 U	NA	NA	
EPA (C9-C18)	199 J	1176 J	435 J	190 U	230 U	220 U	NA	NA	
VPH (C5-C8)	75 U	75 U	75 U	75 U	75 U	75 U	NA	NA	
VPH (C8-C12)	55 U	584	515	55 U	55 U	55 U	NA	NA	
VPH (C9-C10)	12.4 J	400 J	392	20 U	20 U	20 U	NA	NA	
Lead									
Total (6010B)	NA	5 U	5 U	8.5	NA	NA	NA	15	
Dissolved (6010B)	NA	5 U	5 U	5 U	NA	NA	NA	15	
Tetraethyl (ASTM 3341)	(a)	(a)	(a)	(a)	NA	NA	NA	15	

Notes
NA = Not Analyzed/Not Available

(a) = Tetraethyl lead is less than the reporting limit, based on total lead results.

U = Compound is positively detected, the value is in micrograms per liter.

µg/l = micrograms per liter

mg/l = milligrams per liter

U = Compound is positively detected, the value is in micrograms per liter.

Result is greater than the HEDON Drinking Water Final Environmental Action Level (HEDON 2005).

U = Compound is not detected, the value given is the reporting limit.

ENCLOSURE(1)

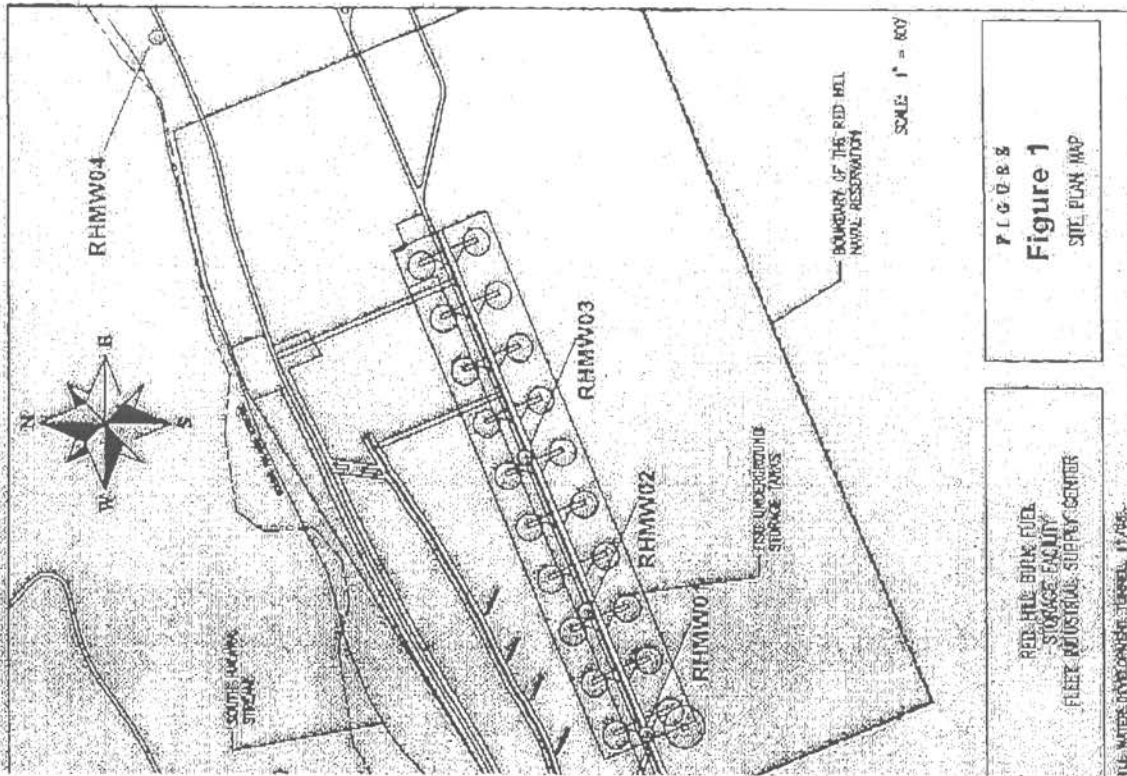

PL0008
Figure 1
 SITE PLAN MAP

RED HILL BUNKER FUEL
 STORAGE FACILITY
 FLEET INDUSTRIAL SUPPLY CENTER
 THE WATER TECHNOLOGISTS COMPANY, P.C.



STATE OF HAWAII
DEPARTMENT OF HEALTH
P. O. BOX 3378
HONOLULU, HAWAII 96801-3378

In reply, please refer to
EVC-SFWB

April 19, 2006

U04007RT

Mr. Darren Uchima
Navy Region Hawaii
Regional Environmental Department, N465
517 Russell Avenue, Suite 110
Pearl Harbor, Hawaii 96860-1884

Dear Mr. Uchima:

SUBJECT: Red Hill Tank Complex
Facility ID 9-102271 / Release IDs 990051, 010011, 020028

The Department of Health (DOH) has reviewed the following reports:

1. *Red Hill Bulk Fuel Storage Facility Work Plan*, dated June 2005 and prepared by NAVFAC Pacific.
2. *Groundwater Sampling*, dated August 2005 and prepared by NAVFAC Pacific.
3. *Groundwater Sampling*, dated November 2005 and prepared by NAVFAC Pacific.
4. *Red Hill Bulk Fuel Storage Facility Draft*, dated January 2006 and prepared by NAVFAC Pacific.
5. *Red Hill Tank Complex Quarterly Progress Report January 2006*, dated January 13, 2006 and prepared by NAVFAC Pacific.

Please note the reports have been placed with the public record.

DOH notes that total dissolved lead was again detected at concentrations higher than DOH Tier 1 action levels for drinking water threatened in monitoring well MW-VD1. Analytical results of 10 parts per billion (ppb) and 12 ppb were reported. This marginally exceeds the DOH action level for potential impacts to aquatic habitats of 5.6 ppb but is below the DOH action level for drinking water concerns of 15 ppb.

Mr. Darren Uchima
April 19, 2006
Page 2

On closer review and due to the significant distance to the nearest surface water body, potential impacts to aquatic habitats are not currently considered to be a concern. All other analyses for BTEX and PAHs were non-detectable or well below DOH Tier 1 action levels.

Thank you for attending the meeting at DOH on January 10, 2006. DOH looks forward to the results of your GIS-based 3-D site model with contaminant fate and transport. It was also stated that a Tier II risk assessment would be conducted prior to the comprehensive Tier III risk assessment for human health and the environment.

Please continue quarterly groundwater monitoring of the existing monitoring wells in the facilities with progress reports sent to this office every 90 days. If you have any questions regarding this letter, please contact Mr. Richard Takaba of our Underground Storage Tank Section at (808) 586-4226.

Sincerely,

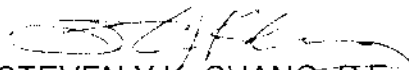
STEVEN Y.K. CHANG, P.E. CHIEF
Solid and Hazardous Waste Branch

c: Roger Brewer, DOH-HEER Office
Glenn Yoshinaga, NAVFAC Pacific, Pearl Harbor
Jeff Hart, TEC, Inc., Honolulu



DEPARTMENT OF THE NAVY

COMMANDER
NAVY REGION HAWAII
850 TICONDEROGA ST STE 110
PEARL HARBOR HI 96860-5101

5090
Ser N45/ 00195
17 JUL 2006

CERTIFIED MAIL NO. 7004 1350 0001 3925 8925

Mr. Richard Takaba
Project Officer
Solid & Hazardous Waste Branch
Environmental Management Division
Hawaii Department of Health
919 Ala Moana Boulevard Room 212
Honolulu HI 96814

SUBJECT: RED HILL TANK COMPLEX QUARTERLY PROGRESS REPORT
(JULY 2006)
FACILITY ID NO. 9-102271/RELEASE ID NOS. 990051,
010011 AND 020028

Dear Mr. Takaba:

In response to the State of Hawaii Department of Health (DOH) Letter, U08023RT, dated August 12, 2004, Navy Region Hawaii is providing the following quarterly progress report as required.

Groundwater and Drinking Water Sampling

Dedicated sampling pumps were installed in five wells. Groundwater samples were collected from the two existing and three newly installed wells on July 10, 2006. The groundwater samples will be analyzed for petroleum constituents. Analytical results will be forwarded to the DOH upon receipt.

Risk Assessment

Navy Region Hawaii provided DOH the Red Hill Bulk Fuel Storage Facility Final - Addendum Planning Documents prepared by TEC on June 1, 2006.

A request for concurrence to authorize TEC and the Water Resources Research Center (WRRRC) at the University of Hawaii to use the Source Water Assessment Program (SWAP) software to conduct the investigation at Red Hill was sent to the DOH Safe Drinking Water Branch on June 15, 2006.

5090
Ser N457 00195
17 JUL 2006

Tank Inspections

Red Hill Tank Inspections have been tentatively scheduled as follows:

FY2006 - Tanks 1, 6, 15 & 16 (currently on-going)
FY2007 - Tanks 11, 17, 18 & 20
FY2008 - Tanks 4 & 5
FY2009 - Tanks 2, 3 & 19

If there are any questions regarding this matter, or if more information is needed, please contact Ms. Raelynn Della Sala at (808) 473-4137, extension 229. The next quarterly progress report will be provided in October 2006.

Sincerely,

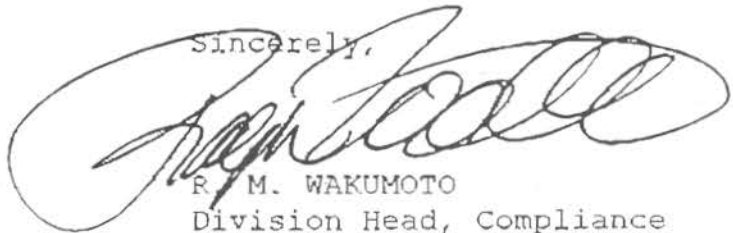

R. M. WAKUMOTO
Division Head, Compliance
Regional Environmental Department
By direction of
Commander, Navy Region Hawaii



DEPARTMENT OF THE NAVY

COMMANDER
NAVY REGION HAWAII
850 TICONDEROGA ST STE 110
PEARL HARBOR HI 96860-5101

5090
Ser N45/

00246

05 SEP 2006

CERTIFIED MAIL NO. 7006 0100 0007 2053 4672

Mr. Richard Takaba
Underground Storage Tank Section
Solid & Hazardous Waste Branch
Environmental Management Division
State of Hawaii Department of Health
919 Ala Moana Boulevard Room 212
Honolulu HI 96814

SUBJECT: RED HILL TANK COMPLEX
JULY 2006 GROUNDWATER SAMPLING RESULTS
FACILITY I.D. NO. 9-102271/RELEASE I.D. NOS. 990051, 010011 AND
020028

Dear Mr. Takaba:

Dedicated sampling pumps were installed in five wells at the Red Hill Fuel Storage Facility (RHMW01, RHMW02, RHMW03, RHMW04, and RHMW2254). The Environmental Company (TEC) Inc. collected groundwater samples from the wells on July 10, 2006. The groundwater samples were analyzed for petroleum constituents.

We are submitting the analytical results for the groundwater samples. A summary table of the analytical results is presented in enclosure (1).

If there are any questions regarding this matter, or if more information is needed, please contact Ms. Raelynn Della Sala at (808) 473-4137, extension 229.

Sincerely,

R. M. WAKUMOTO
Division Head, Compliance
Regional Environmental Department
By direction of
Commander, Navy Region Hawaii

Enclosure: 1. Table 1. Contaminant Concentrations Compared to Table 1-1a Tier 1 Action Levels, HAR Chapter 11-281-80.1, Red Hill Bulk Fuel Storage Facility Site Investigation

Table 1. Contaminant Concentrations Compared to Table 1-1a Tier 1 Action Levels
HAR, Chapter 11-281-80.1
Red Hill Bulk Fuel Storage Facility Site Investigation

Chemical	Department of Health UST TGM Tier 1 Action Levels ug/L	RHMW01-GW02 10-Jul-06 ug/L				RHMW02-GW02 10-Jul-06 ug/L				RHMW02-GW02 Duplicate 10-Jul-06 ug/L			
		Result	Q	RL	MDL	Result	Q	RL	MDL	Result	Q	RL	MDL
8015Mod													
TPH (C10-C28)	NA	509		250	100	2800	U	280	110	2790		270	110
TPH-GRO (C6-C10)	NA	ND	U	100	50	124	U	100	50	119		100	50
SW8270SIM													
Acenaphthene	320	ND	U	1.0	0.50	0.63	J	1.1	0.54	0.58	J	1.0	0.50
Benzo(a)pyrene	0.2	ND	U	0.20	0.10	ND	U	0.22	0.11	ND	U	0.20	0.10
Fluoranthene	13	ND	U	1.0	0.25	ND	U	1.1	0.27	ND	U	1.0	0.25
Naphthalene	240	ND	U	1.0	0.25	171		5.4	1.4	180		5.0	1.3
SW8260													
Benzene	5	ND	U	1.0	0.50	ND	U	1.0	0.50	ND	U	5.0	2.5
1,1-Dichloroethylene	46	ND	U	1.0	0.50	ND	U	1.0	0.50	ND	U	5.0	2.5
Ethylbenzene	140	ND	U	1.0	0.50	1.3		1.0	0.50	ND	U	5.0	2.5
Methyl Tert Butyl Ether	20	ND	U	1.0	0.50	ND	U	1.0	0.50	ND	U	5.0	2.5
Naphthalene	240	ND	U	2.0	1.0	343		10	5.0	335	U	10	5.0
1,1,1-Trichloroethane	200	ND	U	1.0	0.50	ND	U	1.0	0.50	ND	U	5.0	2.5
Tetrachloroethylene	5	ND	U	1.0	0.50	ND	U	1.0	0.50	ND	U	5.0	2.5
Toluene	1000	ND	U	1.0	0.50	ND	U	1.0	0.50	ND	U	5.0	2.5
Trichloroethylene	5	ND	U	1.0	0.50	ND	U	1.0	0.50	ND	U	5.0	2.5
Vinyl chloride	2	ND	U	1.0	0.50	ND	U	1.0	0.50	ND	U	5.0	2.5
m,p-Xylene	10000	ND	U	2.0	0.50	ND	U	2.0	0.50	ND	U	10	2.5
o-Xylene	10000	ND	U	1.0	0.50	ND	U	1.0	0.50	ND	U	5.0	2.5
SW6020													
Lead (Filtered)	5.6	ND	U	10	1.7	ND	U	10	1.7	ND	U	10	1.7

ENCLOSURE(1)

**Table 1. Contaminant Concentrations Compared to Table 1-1a Tier 1 Action Levels
HAR, Chapter 11-281-80.1
Red Hill Bulk Fuel Storage Facility Site Investigation**

Chemical	Department of Health UST TGM Tier 1 Action Levels ug/L	RHMW03-GW02 10-Jul-06 ug/L				RHMW04-GW02 10-Jul-06 ug/L				RHMW2254-01-GW02 10-Jul-06 ug/L			
		Result	Q	RL	MDL	Result	Q	RL	MDL	Result	Q	RL	MDL
8015Mod													
TPH (C10-C28)	NA	142	J	250	100	ND	U	260	100	ND	U	260	110
TPH-GRO (C6-C10)	NA	ND	U	100	50	ND	U	100	50	ND	U	100	50
SW8270SIM													
Acenaphthene	320	ND	U	1.0	0.50	ND	U	1.0	0.51	ND	U	1.0	0.51
Benzo(a)pyrene	0.2	ND	U	0.20	0.10	ND	U	0.20	0.10	ND	U	0.20	0.10
Fluoranthene	13	ND	U	1.0	0.25	ND	U	1.0	0.26	ND	U	1.0	0.26
Naphthalene	240	ND	U	1.0	0.25	ND	U	1.0	0.26	ND	U	1.0	0.26
SW8260													
Benzene	5	ND	U	1.0	0.50	ND	U	1.0	0.50	ND	U	1.0	0.50
1,1-Dichloroethylene	46	ND	U	1.0	0.50	ND	U	1.0	0.50	ND	U	1.0	0.50
Ethylbenzene	140	ND	U	1.0	0.50	ND	U	1.0	0.50	ND	U	1.0	0.50
Methyl Tert Butyl Ether	20	ND	U	1.0	0.50	ND	U	1.0	0.50	ND	U	1.0	0.50
Naphthalene	240	ND	U	2.0	1.0	ND	U	2.0	1.0	ND	U	2.0	1.0
1,1,1-Trichloroethane	200	ND	U	1.0	0.50	ND	U	1.0	0.50	ND	U	1.0	0.50
Tetrachloroethylene	5	ND	U	1.0	0.50	ND	U	1.0	0.50	ND	U	1.0	0.50
Toluene	1000	ND	U	1.0	0.50	ND	U	1.0	0.50	ND	U	1.0	0.50
Trichloroethylene	5	ND	U	1.0	0.50	ND	U	1.0	0.50	ND	U	1.0	0.50
Vinyl chloride	2	ND	U	1.0	0.50	ND	U	1.0	0.50	ND	U	1.0	0.50
m,p-Xylene	10000	ND	U	2.0	0.50	ND	U	2.0	0.50	ND	U	2.0	0.50
o-Xylene	10000	ND	U	1.0	0.50	ND	U	1.0	0.50	ND	U	1.0	0.50
SW6020													
Lead (Filtered)	5.6	ND	U	10	1.7	ND	U	10	3.4	ND	U	10	1.7

ENCLOSURE

Table 1. Contaminant Concentrations Compared to Table 1-1a Tier 1 Action Levels
HAR, Chapter 11-281-80.1
Red Hill Bulk Fuel Storage Facility Site Investigation

Chemical	Department of Health UST TGM Tier 1 Action Levels ug/L	TRIP BLANK 10-Jul-06 ug/L			
		Result	Q	RL	MDL
8015Mod					
TPH (C10-C28)	NA	-	-	-	-
TPH-GRO (C6-C10)	NA	-	-	-	-
SW8270SIM					
Acenaphthene	320	-	-	-	-
Benzo(a)pyrene	0.2	-	-	-	-
Fluoranthene	13	-	-	-	-
Naphthalene	240	-	-	-	-
SW8260					
Benzene	5	ND	U	1	0.5
1,1-Dichloroethylene	46	ND	U	1	0.5
Ethylbenzene	140	ND	U	1	0.5
Methyl Tert Butyl Ether	20	ND	U	1	0.5
Naphthalene	240	ND	U	2	1
1,1,1-Trichloroethane	200	ND	U	1	0.5
Tetrachloroethylene	5	ND	U	1	0.5
Toluene	1000	ND	U	1	0.5
Trichloroethylene	5	ND	U	1	0.5
Vinyl chloride	2	ND	U	1	0.5
m,p-Xylene	10000	ND	U	2	0.5
o-Xylene	10000	ND	U	1	0.5
SW6020					
Lead (Filtered)*	5.6	-	-	-	-

Notes:

- ug/L - Micrograms per Liter
 - UST TGM - Hawaii Department of Health Underground Storage Tank Technical Guidance Manual, Update March 2000
 - Tier 1 Action Levels - Hawaii Administrative Rules, Chapter 11-281 Subchapter 7, Table 1-1a
 - "-" - Not analyzed
 - 343 - Concentration greater than the Tier 1 Action Limit
 - MDL - Method Detection Limit
 - RL - Laboratory Reporting Limit
 - NA - Not applicable
 - ND - Chemical is not detected above the method detection limit
 - Q - Laboratory Data Qualifiers
 - J - Chemical is detected, value is estimated
 - U - Chemical is not detected above the method detection limit
- * Lead RL/MDL are 2x contract RL/MDL to meet low range calibration control limits



DEPARTMENT OF THE NAVY

COMMANDER
NAVY REGION HAWAII
850 TICONDEROGA ST STE 110
PEARL HARBOR HI 96860-5101

5090 00279
Ser N45/
12 OCT 2006

CERTIFIED MAIL NO. 7006 0100 0007 2053 4955

Mr. Richard Takaba
Project Officer
Solid & Hazardous Waste Branch
Environmental Management Division
Hawaii Department of Health
919 Ala Moana Boulevard Room 212
Honolulu Hi 96814

SUBJECT: RED HILL TANK COMPLEX QUARTERLY PROGRESS REPORT
(OCTOBER 2006) FACILITY ID NO. 9-102271/RELEASE ID
NOS. 990051, 010011 AND 020028

Dear Mr. Takaba:

In response to the State of Hawaii Department of Health (DOH) Letter, U08023RT of August 12, 2004, Navy Region Hawaii is providing the following quarterly progress report as required.

Groundwater and Drinking Water Sampling

Dedicated sampling pumps were installed in five wells. Groundwater samples were collected from the two existing and three newly installed wells on July 10, 2006. The groundwater samples were analyzed for petroleum constituents. Analytical results were forwarded to the DOH on September 5, 2006.

As mentioned in the *Red Hill Bulk Fuel Storage Facility Final - Work Plan Addendum* prepared by TEC Inc. of May 2006, Red Hill Storage Facility personnel will be trained to collect future groundwater monitoring samples.

Groundwater samples will be collected and analyzed quarterly. Analytical results will be forwarded to the DOH upon receipt.

Risk Assessment

Navy Region Hawaii provided DOH the *Red Hill Bulk Fuel Storage Facility Final - Addendum Planning Documents* prepared by TEC on June 1, 2006.

5090
Ser N45/ 00279
12 OCT 2006

A request for concurrence to authorize TEC and the Water Resources Research Center at the University of Hawaii to use the Source Water Assessment Program software to conduct the investigation at Red Hill was sent to the DOH Safe Drinking Water Branch on June 15, 2006.

Tank Inspections

Red Hill Tank Inspections have been tentatively scheduled as follows:

- FY2006 - Tanks 15, 16 (Inspection, cleaning and preservation completed. Turnover from contractor to government scheduled for October 11, 2006.)
- FY2007 - Tanks 1, 6 (currently on-going)
- FY2008 - Tanks 11, 17, 18 & 20
- FY2009 - Tanks 4 & 5
- FY2010 - Tanks 2, 3 & 19

If there are any questions regarding this matter, or if more information is needed, please contact Ms. Raelynn Della Sala at (808) 473-4137, extension 229. The next quarterly progress report will be provided in January 2007.

Sincerely,

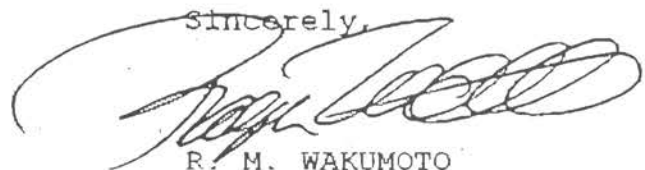

R. M. WAKUMOTO
Division Head, Compliance
Regional Environmental Department
By direction of
Commander, Navy Region Hawaii



DEPARTMENT OF THE NAVY

COMMANDER
NAVY REGION HAWAII
850 TICONDEROGA ST STE 110
PEARL HARBOR HI 96860-5101

5090
Ser N45/00005
08 JAN 2007

CERTIFIED MAIL NO. 7006 0100 0007 2053 9851

Mr. Richard Takaba
Project Officer
Solid and Hazardous Waste Branch
Hawaii Department of Health
919 Ala Moana Boulevard Room 212
Honolulu HI 96814

SUBJECT: NOTIFICATION FOR UNDERGROUND STORAGE TANKS, TANKS 1 AND 19, RED
HILL UNDERGROUND FUEL STORAGE FACILITY
FACILITY ID NO. 9-102271/RELEASE ID NOS. 990051, 010011 AND 020028

Dear Mr. Takaba:

The State of Hawaii Department of Health (DOH) Form No. 1, Notification for Underground Storage Tanks, is being submitted in enclosure (1) to reflect the change in status of Tanks 1 and 19 at the Red Hill Underground Fuel Storage Facility.

Based on your phone conversation with Ms. Raelynn Della Sala on November 21, 2006, the facility is being addressed by the ongoing comprehensive risk assessment and no additional work is required to close the tanks.

If there are any questions regarding this matter, or if more information is needed, please contact Ms. Raelynn Della Sala at (808) 473-4137, extension 229.

Sincerely,

A handwritten signature in black ink, appearing to read "R. M. Wakumoto", written over a large, stylized, circular flourish.

R. M. WAKUMOTO
Division Head, Compliance
Regional Environmental Department
By direction of
Commander, Navy Region Hawaii

Enclosure: 1. DOH Form No. 1, Notification for Underground Storage Tanks, Tanks 1 and 19, Red Hill Underground Fuel Storage Facility, of January 8, 2007

APPENDIX I--NOTIFICATION FOR UNDERGROUND STORAGE TANKS Form No. I (6/99)

Solid and Hazardous Waste Branch, 919 Ala Moana Blvd., Room 212, Honolulu, Hawaii 96814

REASON FOR NOTIFICATION (Check all that apply)

New Notification Change of Owner Change of Operator UST Closure (temporary & permanent)
 Modification. Specify _____ Other: _____

STATE USE ONLY

Facility ID Number _____ Date Received _____
 Date Entered into Computer _____ Data Entry Clerk Initials _____

Please type or print in ink all items except "signature" in section XIII. This form must be completed for each location containing underground storage tanks. For tanks requiring a permit use Form #'s II and III.

I. LOCATION OF TANK(S)

RED HILL UNDERGROUND FUEL STORAGE FACILITY
 Facility Name or Company Site Identifiers, as applicable Location Contact

RED HILL 808-471-0830
 Location Address (P.O. Box not acceptable) Location Phone # (w/ area code) Fax # (w/ area code)

HONOLULU HI 96819 OAHU 9-9-010:006
 City State Zip Code Island Tax Map Key #

II. CONTACT PERSON IN CHARGE OF TANK(S)

TODD CHIPMAN LT COMMANDER 1942 GAFFNEY ST, SUITE 100
 Name Job Title Address

808-473-7801 808-473-7817
 Phone # (with area code) Fax # (with area code)

III. OWNER OF TANK(S) (If same as Section I, check here)

NAVY REGION HAWAII
 Owner Name (Corporation, Individual, Public Agency, or Other Entity)

850 TICONDEROGA ST, STE 110
 Mailing Address

PEARL HARBOR HI 96860-5101
 City State Zip Code Phone # (w/ area code) Fax # (w/ area code)

IV. OPERATOR OF TANK(S) (If same as Section I, check here)

FLEET & INDUSTRIAL SUPPLY
 Operator Name (Corporation, Individual, Public Agency, or Other Entity)

1942 GAFFNEY ST
 Mailing Address

PEARL HARBOR HI 96860 808-473-7802 808-473-7817
 City State Zip Code Phone # (w/ area code) Fax # (w/ area code)

V. TYPE OF OWNER

Federal Government--Military Federal Government--Non-Military State Government
 Local Government Marketer Non-Marketer

VI. TYPE OF FACILITY (Select the appropriate facility description)

Airline Auto Dealership Baseyard Car Rental Cleaner/Laundromat Communication Sites
 Contractor Farm Fire Station Gas Station Golf Course Hospital
 Petroleum Distributor Police Station Residential Resort/Hotel School
 Service Centers/Auto Repair/Maintenance Trucking/Transporter Utilities
 Wastewater Treatment Plants Wholesaler/Retailer Other (Explain) _____

VII. FINANCIAL RESPONSIBILITY (Check all that apply)

Self Insurance Commercial Insurance Risk Retention Group Guarantee Surety Bond
 Letter of Credit Trust Fund Exempt: State or Federal Agency
 Other Method Allowed (Specify) _____

VIII. DESCRIPTION OF TANK(S) (Complete for each at this location)

Tank Number	Tank No. <u>L</u>	Tank No. <u>19</u>	Tank No. <u> </u>	Tank No. <u> </u>	Tank No. <u> </u>
1. Status of Tank (Mark only one)					
A. Currently in Use					
B. Temporarily Out of Use (Also complete Section IX)					
C. Permanently Out of Use (Also complete Section IX)	<input checked="" type="checkbox"/>	<input checked="" type="checkbox"/>			

2. A. Date of Installation (mo./year)	1942	1942			
B. Date of Activity (Modification, Change in owner, etc.) (mo./day/year)					
3. Estimated Total Capacity (gallons)	12.6 M	12.6 M			
4. Substance Currently or Last Stored in Greatest Quantity by Volume					
A. Gasoline					
B. Diesel					
C. Gasohol					
D. Kerosene					
E. Used Oil					
F. JP-4					
G. Non-Petroleum Hazardous Substance (CERCLA name and/or CAS #)					
H. Mixture of Substances, Please specify					
I. Other, Please specify JP-5	X	X			
5. Substance Compatible with Tank and Piping (Y/N)	Y	Y			
6. Tank (Mark all that apply)					
A. Primary Containment Material or Single Walled Tank					
i. Fiberglass reinforced plastic (FRP)					
ii. Steel	X	X			
iii. Other, Please specify					
B. Secondary Containment Material					
i. Double walled					
a. FRP					
b. Steel					
c. Other, Please specify					
ii. Other secondary containment					
a. FRP					
b. Other, Please specify	Concrete	Concrete			
iii. None					
C. Corrosion Protection (except FRP tanks)					
i. Fiberglass coated steel					
ii. Double walled steel					
iii. Impressed current system					
iv. Sacrificial anode system					
v. Corrosion expert determination					

vi. Other, Please specify											
vii. None	X	X									
7. Piping (Mark all that apply)											
A. Primary Containment Material or Single Walled Piping											
i. Rigid fiberglass											
ii. Flex piping											
iii. Steel	X	X									
iv. Other											
B. Type of Secondary Containment											
i. Lined trench											
ii. Rigid double walled piping											
iii. Flex double walled piping											
iv. Other Tunnel/Trench	X	X									
v. None											
C. Corrosion Protection (except FRP piping)											
i. Fiberglass coated steel											
ii. Impressed current system											
iii. Sacrificial anode system											
iv. Corrosion expert determination											
v. Other, Please specify											
vi. None	X	X									
8. Method of Product Dispensing											
A. Suction											
B. Safe Suction											
C. Pressure (Gravity)	X	X									
D. Not Applicable											
9. Spill and Overfill Protection											
A. Overfill device installed	X	X									
i. Automatic shutoff device	X	X									
ii. Overfill alarm	X	X									
iii. Ball float valve											
B. Spill device installed											
10. Release Detection (Mark all that apply)											
	TANK	PIPE	TANK	PIPE	TANK	PIPE	TANK	PIPE	TANK	PIPE	
A. Manual tank gauging		NA		NA		NA		NA		NA	
B. Tank tightness testing		NA		NA		NA		NA		NA	
C. Inventory controls	X	NA	X	NA		NA		NA		NA	
D. Automatic tank gauging	X	NA	X	NA		NA		NA		NA	
E. Vapor monitoring											
F. Groundwater monitoring	X	X	X	X							

IX. TANK(S) OUT OF USE OR CHANGE IN SERVICE

Tank Number	Tank No. <u>1</u>	Tank No. <u>19</u>	Tank No. _____	Tank No. _____	Tank No. _____
1. Closing of Tank					
A. Estimated date last used (mo./day/year)	10/97	12/86			
B. Estimated date tank closed (mo./day/year)	3/07	3/07			
C. Tank was removed from ground	N	N			
D. Tank was closed in ground	Y	Y			
E. Tank filled with inert material Describe	N	N			
F. Change in service	N	N			
2. Site Assessment Completed (Y/N)	Ongoing	Ongoing			
3. Evidence of a Leak Detected (Y/N)	Y	Y			

X. FACILITY DRAWING

Include a drawing showing the general layout of the facility. This drawing should be no larger than 11 by 17 inches and preferably to scale.

This drawing should show the following:

- A. The property boundaries of the facility;
- B. Identification of streets, roads and nearby bodies of water;
- C. Identification of nearby facilities;
- D. Tax Map Key (TMK) Numbers;
- E. Location of buildings at the facility;
- F. The approximate dimensions of the property boundaries and major buildings;
- G. Location of all USTs (identified by number consistent with the tank numbers in Sections VIII - IX), dispenser pumps, and associated pipings; and
- H. Indication of North/South direction.

XI. LOCATION MAP

Include a map showing the location of the tanks with respect to nearby landmarks. The map should indicate roads and landmarks to a level of detail such that the site would be easily located.

FACILITY DRAWING
 RED HILL
 UNDERGROUND FUEL
 STORAGE
 SHEET 1 OF 2

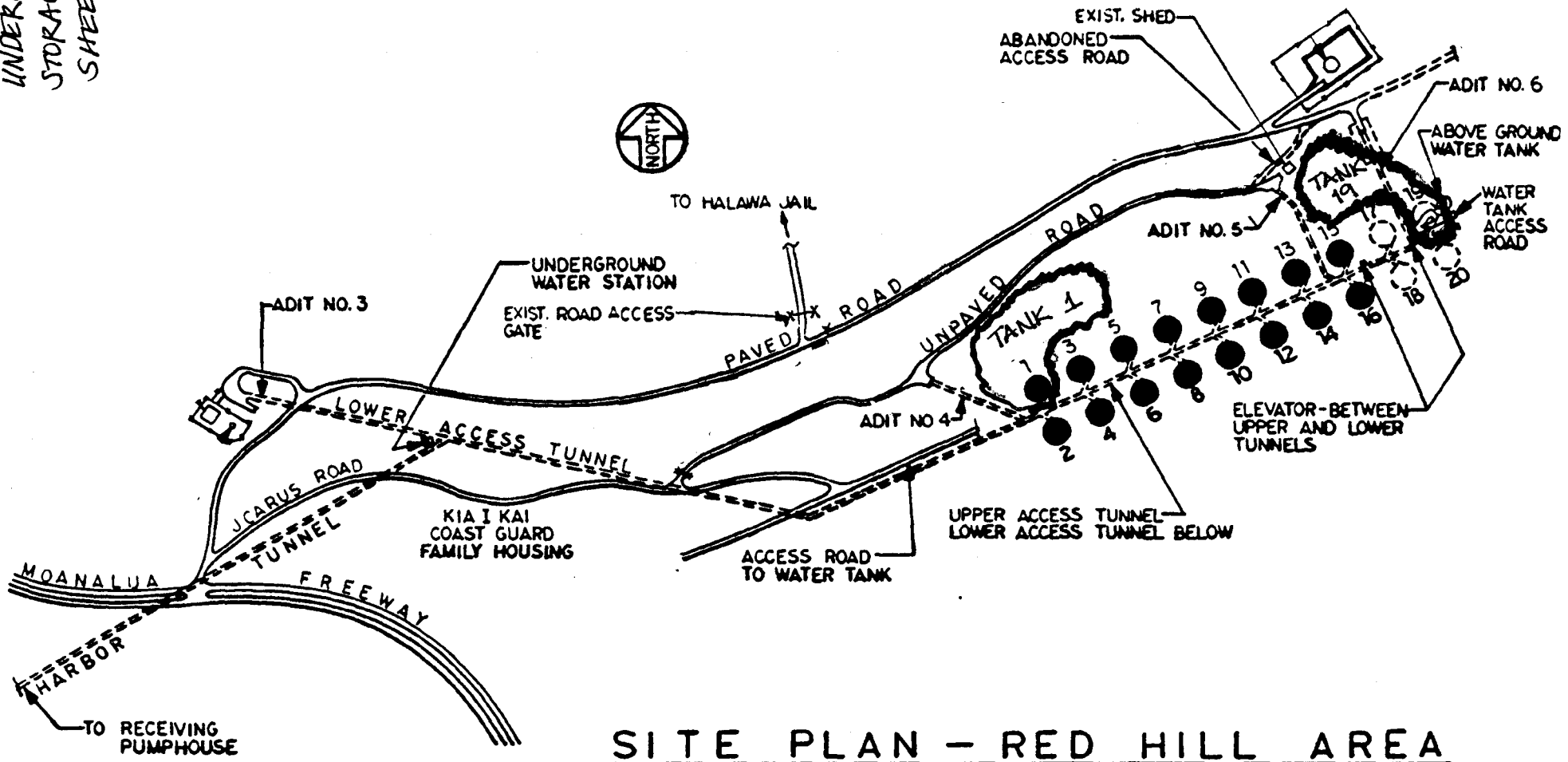

SITE PLAN - RED HILL AREA



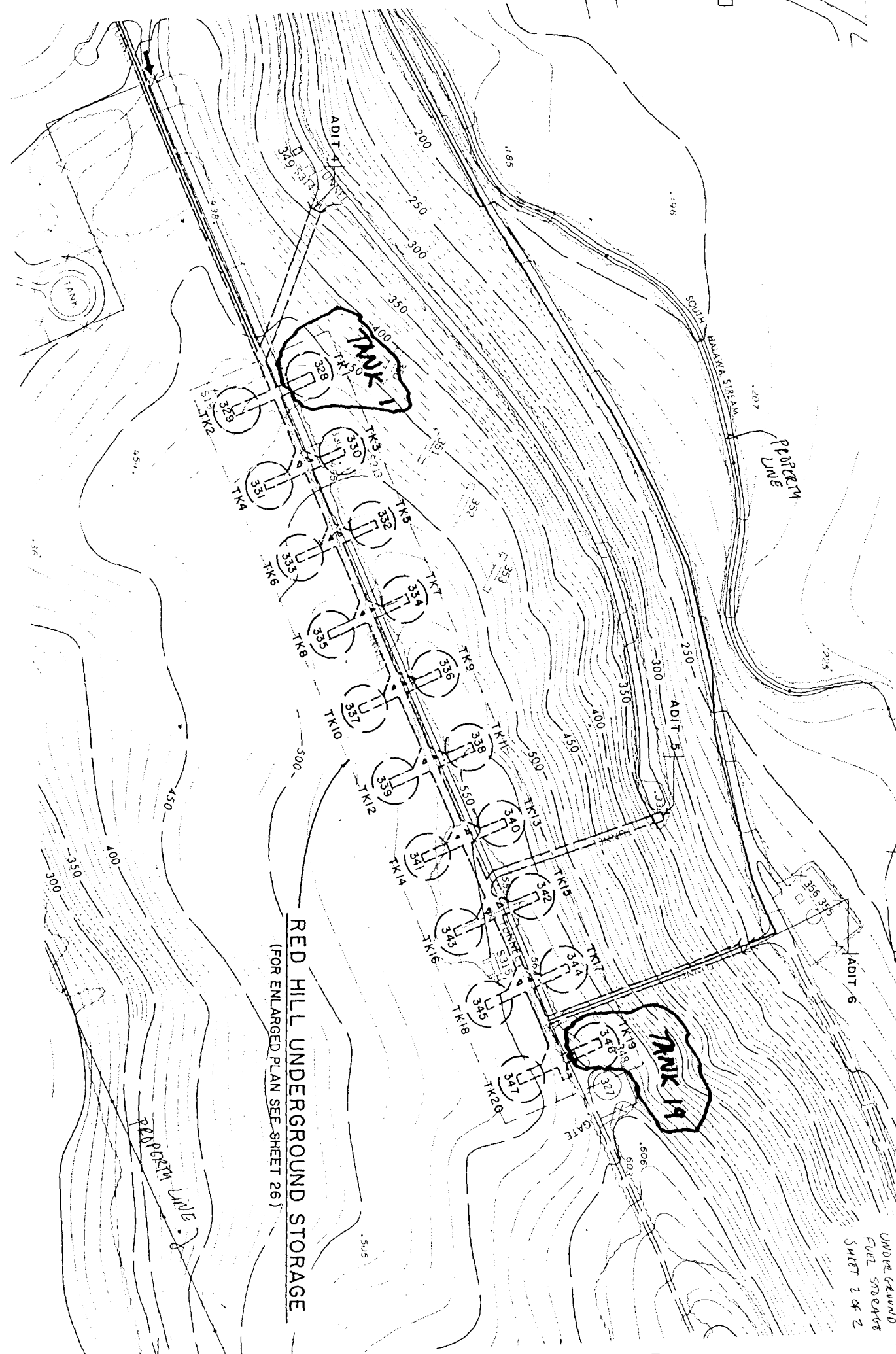

RED HILL UNDERGROUND STORAGE

(FOR ENLARGED PLAN SEE SHEET 26)

RED HILL
UNDERGROUND
FUEL STORAGE
SHEET 2 OF 2

LOCATION
 MAP
 RED HIL
 UNDERGROU
 FUEL
 STORAGE
 SHEET
 1 OF 1

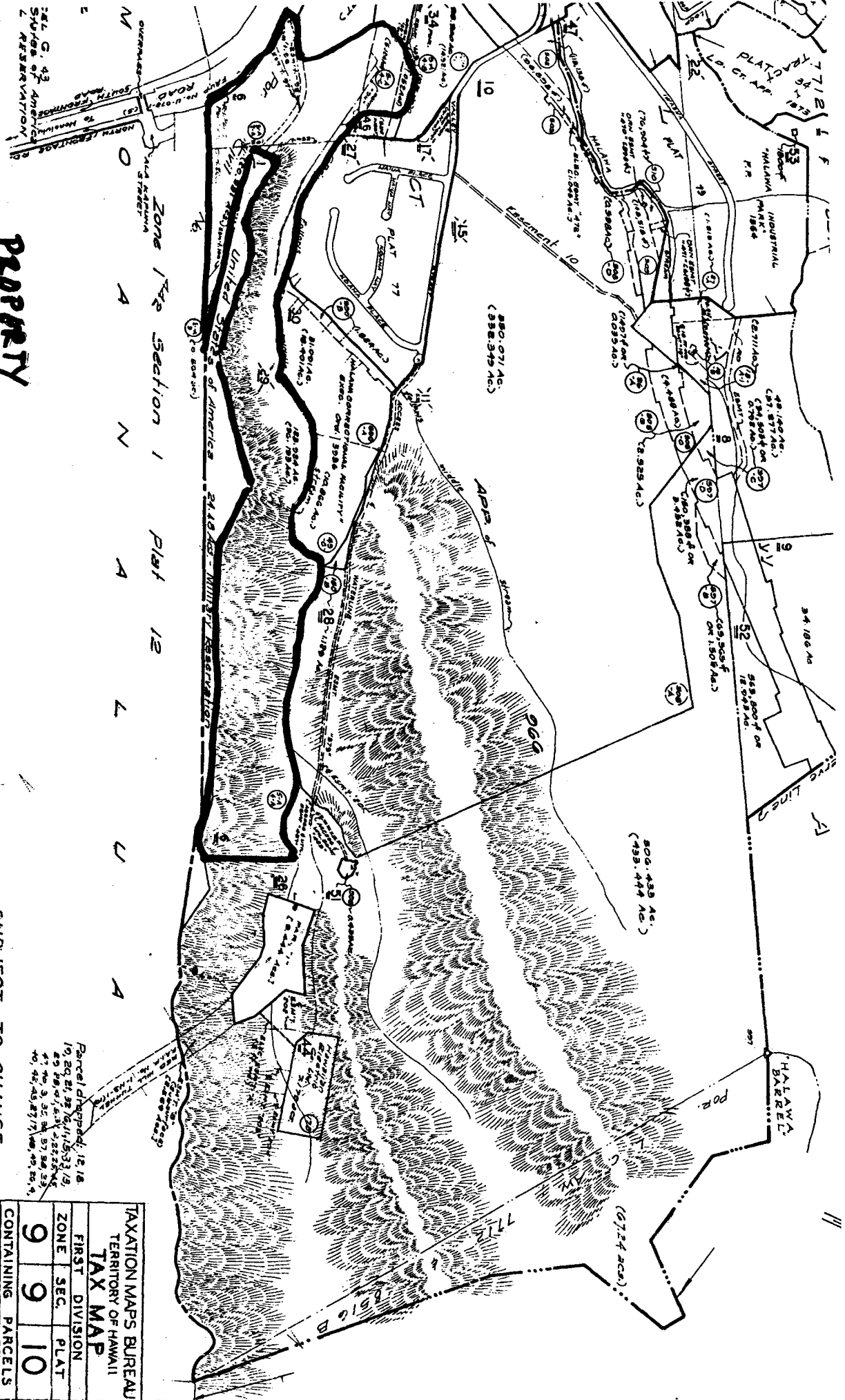

**PROPERTY
 BOUNDARY**

9-9-10:006

SUBJECT TO CHANGE

TAXATION MAPS BUREAU			
TERRITORY OF HAWAII			
TAX MAP			
FIRST DIVISION	ZONE	SEC.	PLAT
9	9	10	
CONTAINING PARCELS			
SCALE			

Parcel changed: 12, 16,
 19, 20, 21, 22, 23, 24, 25,
 26, 27, 28, 29, 30, 31,
 32, 33, 34, 35, 36, 37, 38,
 39, 40, 41, 42, 43, 44, 45, 46,
 47, 48, 49, 50, 51, 52, 53,
 54, 55, 56, 57, 58, 59, 60,
 61, 62, 63, 64, 65, 66, 67,
 68, 69, 70, 71, 72, 73, 74,
 75, 76, 77, 78, 79, 80, 81,
 82, 83, 84, 85, 86, 87, 88,
 89, 90, 91, 92, 93, 94, 95,
 96, 97, 98, 99, 100

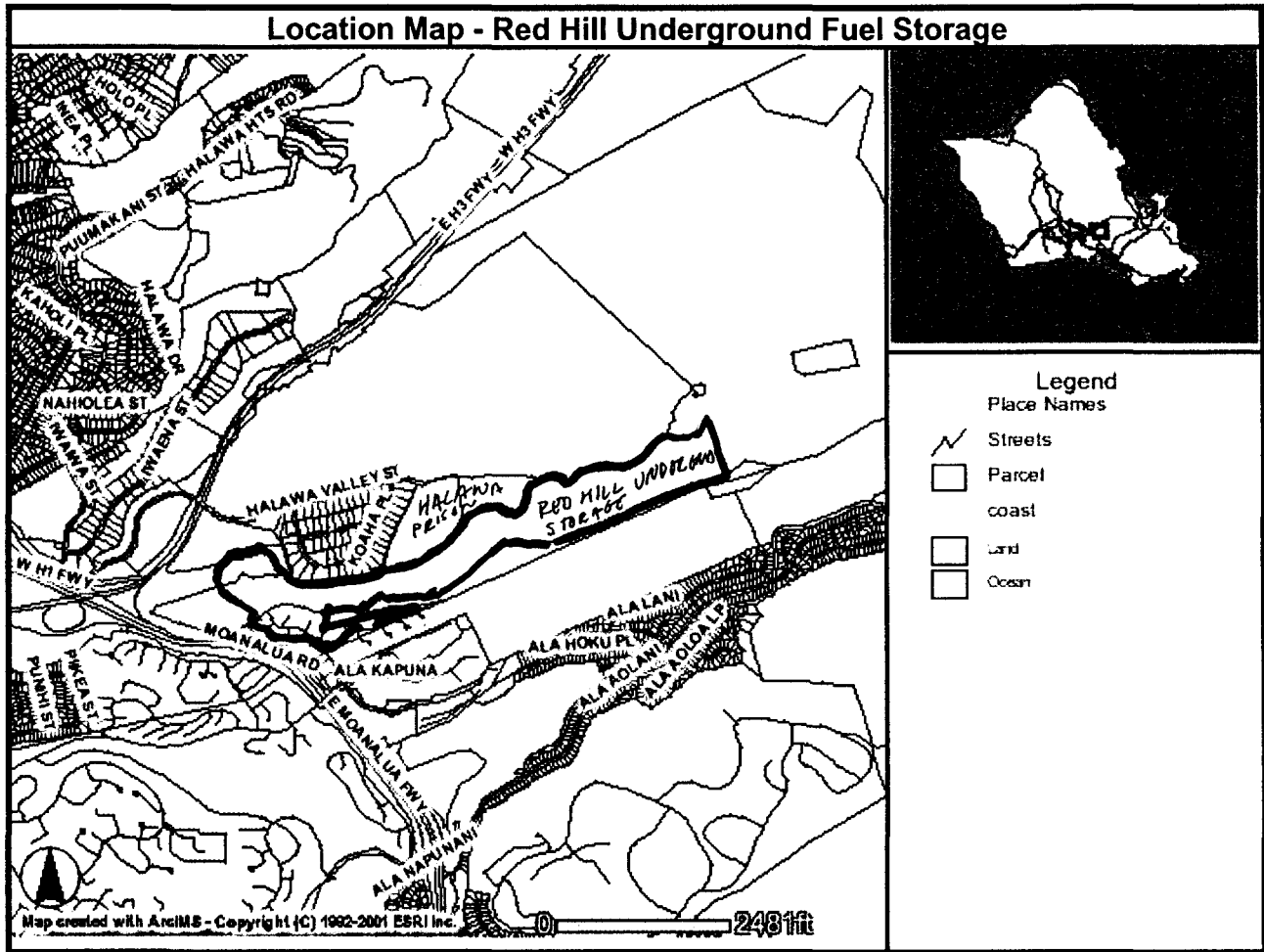

SHEET 2 OF 2



DEPARTMENT OF THE NAVY

COMMANDER
NAVY REGION HAWAII
850 TICONDEROGA ST STE 110
PEARL HARBOR HI 96860-5101

5090
Ser N45/00011
11 JAN 2007

CERTIFIED MAIL NO. 7006 0100 0007 2053 9882

Mr. Richard Takaba
Project Officer
Solid and Hazardous Waste Branch
Hawaii Department of Health
919 Ala Moana Boulevard Room 212
Honolulu HI 96814

SUBJECT: RED HILL TANK COMPLEX QUARTERLY PROGRESS REPORT
(JANUARY 2007)
FACILITY ID NO. 9-102271/RELEASE ID NOS. 990051,
010011 AND 020028

Dear Mr. Takaba:

In response to the State of Hawaii Department of Health (DOH) Letter, U08023RT, of August 12, 2004, Navy Region Hawaii is providing the following quarterly progress report as required.

Groundwater and Drinking Water Sampling

Groundwater samples were collected from four wells on December 5, 2006. The groundwater samples were analyzed for petroleum constituents. Analytical results will be forwarded to the DOH upon receipt.

As mentioned in the *Red Hill Bulk Fuel Storage Facility Final - Work Plan Addendum* prepared by TEC Inc. and dated May 2006, Red Hill Storage Facility personnel will be trained to collect future groundwater monitoring samples.

Groundwater samples will be collected and analyzed quarterly. Analytical results will be forwarded to the DOH upon receipt.

Risk Assessment

Navy Region Hawaii provided DOH the *Red Hill Bulk Fuel Storage Facility Final - Addendum Planning Documents* prepared by TEC on June 1, 2006.

5090
Ser N45/00011
11 JAN 2007

A request for concurrence to authorize TEC and the Water Resources Research Center (WRRRC) at the University of Hawaii to use the Source Water Assessment Program (SWAP) software to conduct the investigation at Red Hill was sent to the DOH Safe Drinking Water Branch on June 15, 2006.

Tank Inspections

Red Hill Tank Inspections have been tentatively scheduled as follows:

- FY2006 - Tanks 15 & 16 (Inspection, cleaning, and preservation completed. Turnover from contractor to government completed.)
- FY2007 - Tanks 1 & 6 (currently on-going)
- FY2008 - Tanks 11, 17, 18 & 20
- FY2009 - Tanks 4 & 5
- FY2010 - Tanks 2, 3 & 19

Due to tank coating failure observed in Tank 1 and the high repair cost, the Navy has decided to take Tank 1 out of service. In addition, Tank 19 is no longer in use. DOH Form No. 1, Notification for Underground Storage Tanks, was submitted to the DOH on January 8, 2007 to reflect the change in status of Tanks 1 and 19.

If there are any questions regarding this matter, or if more information is needed, please contact Ms. Raelynn Della Sala at (808) 473-4137, extension 229. The next quarterly progress report will be provided in April 2007.

Sincerely,

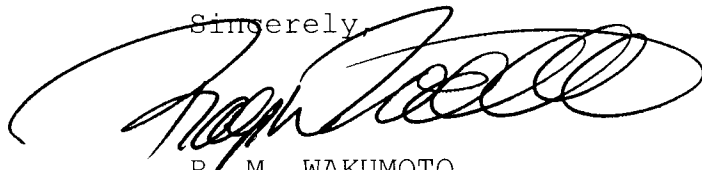

R. M. WAKUMOTO
Division Head, Compliance
Regional Environmental Department
By direction of
Commander, Navy Region Hawaii



DEPARTMENT OF THE NAVY

COMMANDER
NAVY REGION HAWAII
850 TICONDEROGA ST STE 110
PEARL HARBOR HI 96860-5101

5090
Ser N45/00131
04 MAY 2007

CERTIFIED MAIL NO. 7006 0100 0007 2053 8908

Mr. Richard Takaba
Underground Storage Tank Section
Solid & Hazardous Waste Branch
Environmental Management Division
Hawaii State Department of Health
919 Ala Moana Boulevard Room 212
Honolulu HI 96814

Dear Mr. Takaba:

SUBJECT: RED HILL TANK COMPLEX
MARCH 2007 GROUNDWATER SAMPLING RESULTS
FACILITY ID NO. 9-102271 / RELEASE ID NOS. 990051, 010C11
AND 020028

The Environmental Company (TEC) Inc. collected groundwater samples from four wells on March 27, 2007. The groundwater samples were analyzed for petroleum constituents.

We are submitting the analytical results for the groundwater samples. A summary table of the analytical results is presented in enclosure (1).

If there are any questions regarding this matter, or if more information is needed, please contact Ms. Raelynn Della Sala at (808) 473-4137, extension 229.

Sincerely,

A handwritten signature in black ink, appearing to read "R. M. Wakumoto", written over a large, stylized flourish.

R. M. WAKUMOTO
Division Head, Compliance
Regional Environmental Department
By direction of the Commander

Enclosure: 1. Table 1. Analytical Results for Quarterly Groundwater Sampling Release Response Report, March 27, 2007, Red Hill Fuel Storage Facility, Hawaii

Table 1. Analytical Results for Quarterly Groundwater Sampling Release Response Report, March 27, 2007
Red Hill Fuel Storage Facility, Hawaii

Method	Chemical	HDOH Residential Drinking Water EALs ¹ UG/L	HDOH Drinking Water Ceiling EALs ² UG/L	RHMW01 UG/L March 27, 2007				RHMW02 UG/L March 27, 2007				RHMW02D- UG/L March 27, 2007				RHMW03 UG/L March 27, 2007				RHMW2254-01 UG/L March 27, 2007			
				Result	Q	MDL	RL	Result	Q	MDL	RL	Result	Q	MDL	RL	Result	Q	MDL	RL	Result	Q	MDL	RL
SW8015V	TPH as GASOLINE RANGE ORGANICS	100	100	ND	U	50	100	122	0	50	100	148	0	50	100	ND	U	50	100	ND	U	50	100
SW8015E	PETROLEUM HYDROCARBONS ABOVE C-10	100	100	307	0	98	250	2750	0	97	240	2250	0	190	490	95.7	J	95	240	ND	U	98	250
SW8260B	1,1,1,2-TETRACHLOROETHANE	0.43	50000	ND	U	0.5	1	ND	U	0.5	1	ND	U	0.5	1	ND	U	0.5	1	ND	U	0.5	1
	1,1,1-TRICHLOROETHANE	200	970	ND	U	0.5	1	ND	U	0.5	1	ND	U	0.5	1	ND	U	0.5	1	ND	U	0.5	1
	1,1,2,2-TETRACHLOROETHANE	0.056	500	ND	U	0.4	1	ND	U	0.4	1	ND	U	0.4	1	ND	U	0.4	1	ND	U	0.4	1
	1,1,2-TRICHLOROETHANE	5	50000	ND	U	0.5	1	ND	U	0.5	1	ND	U	0.5	1	ND	U	0.5	1	ND	U	0.5	1
	1,2,4-TRICHLOROBENZENE	70	3000	ND	U	0.5	1	ND	U	0.5	1	ND	U	0.5	1	ND	U	0.5	1	ND	U	0.5	1
	1,2-DIBROMO-3-CHLOROPROPANE (DBCP)	0.04	10	ND	U	1	2	ND	U	1	2	ND	U	1	2	ND	U	1	2	ND	U	1	2
	1,2-DICHLOROPROPANE	5	10	ND	U	0.5	1	ND	U	0.5	1	ND	U	0.5	1	ND	U	0.5	1	ND	U	0.5	1
	1,3-DICHLOROBENZENE	180	50000	ND	U	0.5	1	ND	U	0.5	1	ND	U	0.5	1	ND	U	0.5	1	ND	U	0.5	1
	1,3-DICHLOROPROPANE	0.4	50000	ND	U	0.5	1	ND	U	0.5	1	ND	U	0.5	1	ND	U	0.5	1	ND	U	0.5	1
	1,4-DICHLOROBENZENE	75	5	ND	U	0.5	1	ND	U	0.5	1	ND	U	0.5	1	ND	U	0.5	1	ND	U	0.5	1
	ACETONE	5500	20000	ND	U	5	25	ND	U	5	25	ND	U	5	25	ND	U	5	25	ND	U	5	25
	BENZENE	5	170	ND	U	0.5	1	ND	U	0.5	1	ND	U	0.5	1	ND	U	0.5	1	ND	U	0.5	1
	BROMODICHLOROMETHANE	0.18	50000	ND	U	0.5	1	ND	U	0.5	1	ND	U	0.5	1	ND	U	0.5	1	ND	U	0.5	1
	BROMOFORM	100	510	ND	U	0.5	1	ND	U	0.5	1	ND	U	0.5	1	ND	U	0.5	1	ND	U	0.5	1
	BROMOMETHANE	8.5	50000	ND	U	1	2	ND	U	1	2	ND	U	1	2	ND	U	1	2	ND	U	1	2
	CARBON TETRACHLORIDE	5	520	ND	U	0.5	1	ND	U	0.5	1	ND	U	0.5	1	ND	U	0.5	1	ND	U	0.5	1
	CHLOROETHANE	3.9	16	ND	U	1	2	ND	U	1	2	ND	U	1	2	ND	U	1	2	ND	U	1	2
	CHLOROFORM	100	2400	ND	U	0.5	1	ND	U	0.5	1	ND	U	0.5	1	ND	U	0.5	1	ND	U	0.5	1
	CHLOROMETHANE	160	50000	ND	U	1	2	ND	U	1	2	ND	U	1	2	ND	U	1	2	ND	U	1	2
	cis-1,2-DICHLOROETHYLENE	70	50000	ND	U	0.5	1	ND	U	0.5	1	ND	U	0.5	1	ND	U	0.5	1	ND	U	0.5	1
	DIBROMOMETHANE	0.0056	50000	ND	U	0.5	2	ND	U	0.5	2	ND	U	0.5	2	ND	U	0.5	2	ND	U	0.5	2
	ETHYLBENZENE	700	30	ND	U	0.5	1	ND	U	0.5	1	ND	U	0.5	1	ND	U	0.5	1	ND	U	0.5	1
	HEXACHLOROBUTADIENE	0.86	6	ND	U	0.5	2	ND	U	0.5	2	ND	U	0.5	2	ND	U	0.5	2	ND	U	0.5	2
	M,P-XYLENE (SUM OF ISOMERS)	10000	20	ND	U	0.5	2	ND	U	0.5	2	ND	U	0.5	2	ND	U	0.5	2	ND	U	0.5	2
METHYL ETHYL KETONE (2-BUTANONE)	7000	8400	ND	U	2.5	5	ND	U	2.5	5	ND	U	2.5	5	ND	U	2.5	5	ND	U	2.5	5	
METHYL ISOBUTYL KETONE (4-METHYL-2-PENTANONE)	2000	1300	ND	U	2.5	5	ND	U	2.5	5	ND	U	2.5	5	ND	U	2.5	5	ND	U	2.5	5	
METHYLENE CHLORIDE	4.3	9100	ND	U	1	5	ND	U	1	5	ND	U	1	5	ND	U	1	5	ND	U	1	5	
NAPHTHALENE	6.2	21	ND	U	1	2	196	0	10	20	207	0	5	10	ND	U	1	2	ND	U	1	2	
STYRENE	100	10	ND	U	0.5	1	ND	U	0.5	1	ND	U	0.5	1	ND	U	0.5	1	ND	U	0.5	1	
TETRACHLOROETHYLENE(PCE)	5	170	ND	U	0.5	1	ND	U	0.5	1	ND	U	0.5	1	ND	U	0.5	1	ND	U	0.5	1	
TOLUENE	1000	40	ND	U	0.5	1	ND	U	0.5	1	ND	U	0.5	1	ND	U	0.5	1	ND	U	0.5	1	
trans-1,2-DICHLOROETHENE	100	260	ND	U	0.5	1	ND	U	0.5	1	ND	U	0.5	1	ND	U	0.5	1	ND	U	0.5	1	
TRICHLOROETHYLENE (TCE)	5	310	ND	U	0.5	1	ND	U	0.5	1	ND	U	0.5	1	ND	U	0.5	1	ND	U	0.5	1	
VINYL CHLORIDE	2	3400	ND	U	0.5	1	ND	U	0.5	1	ND	U	0.5	1	ND	U	0.5	1	ND	U	0.5	1	
SW8270C	1-METHYLNAPHTHALENE	240	10	ND	U	0.25	0.99	72.1	0	0.96	3.8	59.4	0	0.96	3.8	ND	U	0.25	0.98	ND	U	0.24	0.97
	2-METHYLNAPHTHALENE	240	10	ND	U	0.25	0.99	30.3	0	0.24	0.96	26.2	0	0.24	0.96	ND	U	0.25	0.98	ND	U	0.24	0.97
	ACENAPHTHENE	370	20	ND	U	0.5	0.99	0.66	J	0.48	0.96	0.56	J	0.48	0.96	ND	U	0.49	0.98	ND	U	0.49	0.97
	ACENAPHTHYLENE	240	2000	ND	U	0.5	0.99	ND	U	0.48	0.96	ND	U	0.48	0.96	ND	U	0.49	0.98	ND	U	0.49	0.97
	ANTHRACENE	1800	22	ND	U	0.5	0.99	ND	U	0.48	0.96	ND	U	0.48	0.96	ND	U	0.49	0.98	ND	U	0.49	0.97
	BENZO(a)PYRENE	0.2	1.9	ND	U	0.099	0.2	ND	U	0.096	0.19	ND	U	0.096	0.19	ND	U	0.098	0.2	ND	U	0.097	0.19
	BENZO(b)FLUORANTHENE	0.092	7	ND	U	0.05	0.2	ND	U	0.048	0.19	ND	U	0.048	0.19	ND	U	0.049	0.2	ND	U	0.049	0.19
	BENZO(g,h,i)PERYLENE	1500	0.13	ND	U	0.099	0.2	ND	U	0.096	0.19	ND	U	0.096	0.19	ND	U	0.098	0.2	ND	U	0.097	0.19
	BENZO(k)FLUORANTHENE	0.92	0.4	ND	U	0.099	0.2	ND	U	0.096	0.19	ND	U	0.096	0.19	ND	U	0.098	0.2	ND	U	0.097	0.19
	CHRYSENE	9.2	0.8	ND	U	0.099	0.2	ND	U	0.096	0.19	ND	U	0.096	0.19	ND	U	0.098	0.2	ND	U	0.097	0.19
	DIBENZ(a,h)ANTHRACENE	0.0092	0.25	ND	U	0.05	0.2	ND	U	0.048	0.19	ND	U	0.048	0.19	ND	U	0.049	0.2	ND	U	0.049	0.19
	FLUORANTHENE	1500	130	ND	U	0.25	0.99	ND	U	0.24	0.96	ND	U	0.24	0.96	ND	U	0.25	0.98	ND	U	0.24	0.97
	FLUORENE	240	950	ND	U	0.25	0.99	0.26	J	0.24	0.96	0.26	U	0.24	0.96	ND	U	0.25	0.98	ND	U	0.24	0.97
	INDENO(1,2,3-c,d)PYRENE	0.092	0.27	ND	U	0.05	0.2	ND	U	0.048	0.19	ND	U	0.048	0.19	ND	U	0.049	0.2	ND	U	0.049	0.19
	NAPHTHALENE	6.2	21	ND	U	0.25	0.99	105	0	0.96	3.8	90.1	0	0.96	3.8	ND	U	0.25	0.98	ND	U	0.24	0.97
	PHENANTHRENE	240	410	ND	U	0.5	0.99	ND	U	0.48	0.96	ND	U	0.48	0.96	ND	U	0.49	0.98	ND	U	0.49	0.97
	PYRENE	180	68	ND	U	0.25	0.99	ND	U	0.24	0.96	ND	U	0.24	0.96	ND	U	0.25	0.98	ND	U	0.24	0.97
	SW6010BFiltered	LEAD	15	50000	1.7	J	1.7	5	1.7	J	1.7	5	1.7	U	1.7	5	3	J	1.7	5	ND	U	1.7

UG/L - micrograms per Liter
Q - data qualifier
U - Indicates that the compound was analyzed for but not detected at or above the stated limit
J - Indicates an estimated value
MDL - method detection limit
RL - reporting limit
TPH - Total Petroleum hydrocarbons
ND - Indicates that the compound was analyzed for but not detected at or above the stated limit
200 - Result exceeds one or both HDOH EAL's
¹ Toxicity-based environmental action levels, Table D-2, *Screening For Environmental Concerns At Sites With Contaminated Soil and Groundwater*, HDOH, 2005
² Taste, odor and solubility thresholds, Table G-1, *Screening For Environmental Concerns At Sites With Contaminated Soil and Groundwater*, HDOH, 2005



DEPARTMENT OF THE NAVY

COMMANDER
NAVY REGION HAWAII
850 TICONDEROGA ST STE 110
PEARL HARBOR HI 96860-5101

5090
Ser N45/00203
13 JUL 2007

CERTIFIED MAIL NO. 7006 0100 0007 2053 8557

Mr. Richard Takaba
Project Officer
Solid & Hazardous Waste Branch
Hawaii State Department of Health
919 Ala Moana Boulevard Room 212
Honolulu HI 96814

Dear Mr. Takaba:

SUBJECT: RED HILL TANK COMPLEX QUARTERLY PROGRESS REPORT
(JULY 2007) FACILITY ID NO. 9-102271/RELEASE ID NOS.
990051, 010011 AND 020028

In response to the State of Hawaii Department of Health (DOH) Letter, U08023RT, dated August 12, 2004, Navy Region Hawaii is providing the following quarterly progress report as required.

Groundwater and Drinking Water Sampling

Groundwater samples were collected from four wells in March 2007. The samples were analyzed for petroleum constituents. Analytical results were forwarded to the DOH on May 4, 2007.

Quarterly groundwater monitoring samples were collected from four wells in June 2007. The groundwater samples were analyzed for petroleum constituents. Analytical results will be forwarded to the DOH upon receipt.

Risk Assessment

Navy Region Hawaii provided DOH the Red Hill Bulk Fuel Storage Facility Final - Addendum Planning Documents prepared by TEC on June 1, 2006.

A Site Investigation Report is being prepared and will be forwarded to the DOH upon completion.

5090
Ser N45/00203
13 JUL 2007

Tank Inspections

Red Hill Tank Inspections have been tentatively scheduled as follows:

FY2006 - Tanks 15 & 16 (Inspection, cleaning, and preservation completed. Turnover from contractor to government completed.)
FY2007 - Tanks 6 (currently on-going)
FY2008 - Tanks 2 & 20
FY2009 - Tanks 5, 17, & 18
FY2010 - Tanks 3, 11, & 19
FY2011 - Tank 4

If there are any questions regarding this matter, or if more information is needed, please contact Ms. Raelynn Della Sala at (808) 473-4137, extension 229. The next quarterly progress report will be provided in October 2007.

Sincerely,

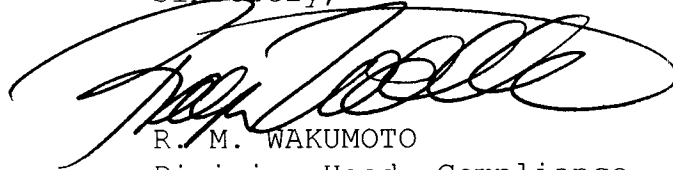

R. M. WAKUMOTO
Division Head, Compliance
Regional Environmental Department
By direction of the
Commander



DEPARTMENT OF THE NAVY

COMMANDER
NAVY REGION HAWAII
850 TICONDEROGA ST STE 110
PEARL HARBOR HI 96860-5101

5090
Ser N45/00287
12 OCT 2007

CERTIFIED MAIL NO. 7006 0100 0007 2053 5754

Mr. Richard Takaba
Underground Storage Tank Section
Solid and Hazardous Waste Branch
Environmental Management Division
State of Hawaii Department of Health
919 Ala Moana Boulevard Room 212
Honolulu HI 96814

Dear Mr. Takaba:

SUBJECT: RED HILL TANK COMPLEX QUARTERLY PROGRESS REPORT
(OCTOBER 2007)
FACILITY ID NO. 9-102271 / RELEASE ID NO. 99051,
010011 AND 020028

In response to the State of Hawaii Department of Health (DOH) Letter, U08023RT, dated August 12, 2004, Navy Region Hawaii is providing the following quarterly progress report as required.

Groundwater and Drinking Water Sampling

Groundwater samples were collected from four wells in June 2007. The samples were analyzed for petroleum constituents. Analytical results were forwarded to the DOH on August 20, 2007.

Quarterly groundwater monitoring samples were collected from four wells in September 2007. The groundwater samples were analyzed for petroleum constituents. Analytical results will be forwarded to the DOH upon receipt.

Risk Assessment

A Site Investigation and Risk Assessment Technical Report was completed and forwarded to the DOH on August 23, 2007.

A Contingency Plan is being prepared and will be forwarded to the DOH upon completion.

5090
Ser N45/00287
12 OCT 2007

Tank Inspections

Red Hill Tank Inspections have been tentatively scheduled as follows:

FY2006 - Tanks 15 & 16 (Inspection, cleaning, and preservation completed. Turnover from contractor to government completed.)
FY2007/- Tanks 6 (currently on-going), 2, & 20
FY2008
FY2009 - Tanks 5, 17, & 18
FY2010 - Tanks 3, 11, & 19
FY2011 - Tank 4

If there are any questions regarding this matter, or if more information is needed, please contact Ms. Raelynn Della Sala at (808) 471-1171, extension 337. The next quarterly progress report will be provided in January 2008.

Sincerely,

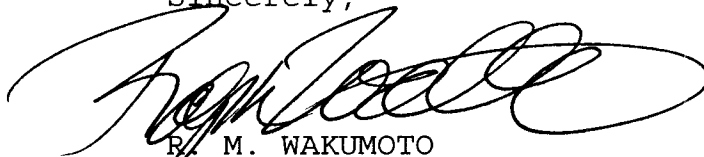

R. M. WAKUMOTO
Division Head, Compliance
Regional Environmental Department
By direction of the
Commander



DEPARTMENT OF THE NAVY

COMMANDER
NAVY REGION HAWAII
850 TICONDEROGA ST STE 110
PEARL HARBOR HI 96860-5101

5090
Ser N45/00291
16 OCT 2007

CERTIFIED MAIL NO. 7006 0100 0007 2053 5778

Mr. Richard Takaba
Underground Storage Tank Section
Solid and Hazardous Waste Branch
Environmental Management Division
State of Hawaii Department of Health
919 Ala Moana Boulevard Room 212
Honolulu HI 96814

Dear Mr. Takaba:

SUBJECT: RED HILL TANK COMPLEX
SEPTEMBER 2007 GROUNDWATER SAMPLING RESULTS
FACILITY ID NO. 9-102271 / RELEASE ID NO. 99051, 010011 AND
020028

The Environmental Company (TEC) Inc. collected groundwater samples from four wells on September 10, 2007. The groundwater samples were analyzed for petroleum constituents. We are submitting the analytical results for the groundwater samples in Enclosure 1.

If there are any questions regarding this matter, or if more information is needed, please contact Ms. Raelynn Della Sala at (808) 471-1171, extension 337.

Sincerely,

A handwritten signature in black ink, appearing to read "R. M. Wakumoto".

R. M. WAKUMOTO
Division Head, Compliance
Regional Environmental Department
By direction of the
Commander

Enclosure: 1. Table 1 - Analytical Results for Quarterly Groundwater Sampling Release Response Report, September 10, 2007, Red Hill Fuel Storage Facility, Hawaii

Appendix B
Modified API 653 Tank Inspection Procedure Completed Forms
(Available on CD Only)

Appendix C
Groundwater Monitoring Field Sampling and Analysis Plan

**Red Hill Bulk Fuel Storage Facility
Final
Groundwater Field Sampling Plan
Pearl Harbor, Hawaii**

August 2007

**Department of the Navy
Commander
Naval Facilities Engineering Command, Pacific
Pearl Harbor, HI 96860-3134**



Indefinite Delivery/ Indefinite Quantity Contract
Contract Number N62742-02-D-1802, CTO 007

Red Hill Bulk Fuel Storage Facility Final Groundwater Field Sampling Plan Pearl Harbor, Hawaii

August 2007

Prepared for:



**Department of the Navy
Commander
Naval Facilities Engineering Command, Pacific
258 Makalapa Drive, Suite #100
Pearl Harbor, HI 96860-3134**

Prepared by:

**TEC Inc.
1001 Bishop Street,
American Savings Bank Tower, Suite 1400
Honolulu, Hawaii 96813**

Prepared under:

**Indefinite Delivery/ Indefinite Quantity Contract
Contract Number N62742-02-D-1802, CTO 007**

TABLE OF CONTENTS

1.0 INTRODUCTION.....	1-1
1.1 Pre-Sample Operations	1-1
1.1.1 Field Equipment.....	1-1
1.1.2 Pre-Sample Operations	1-1
1.1.3 Purging Prior to Sampling.....	1-4
2.0 SAMPLE COLLECTION	2-1
2.1 Trip Blank.....	2-1
2.2 Field Duplicates.....	2-1
2.3 Matrix Spike/Matrix Spike Duplicate	2-2
3.0 SAMPLE DOCUMENTATION AND HANDLING.....	3-1
3.1 Field Logbook	3-1
3.2 Sample Management.....	3-1
4.0 DECONTAMINATION AND INVESTIGATIVE DERIVED WASTE.....	4-1
4.1 Equipment Decontamination.....	4-1
4.2 Investigative Derived Waste	4-1

LIST OF TABLES

Table 1-1. Monitoring Well Construction Information	1-3
Table 1-2 Groundwater Sampling Pump Requirement	1-5
Table 2-1 Summary of Groundwater Sampling Analyses	2-3
Table 2-2 Summary of Groundwater Sampling Containers, Preservatives and Hold Times.....	2-4

LIST OF FIGURES

Figure 1-1 Groundwater Sampling Locations.....	1-6
--	-----

LIST OF APPENDICES

Appendix A	Installation of Dedicated Equipment
Appendix B	Groundwater Sampling Forms
Appendix C	Geocontroller 2
Appendix D	Geotech Bladder Pumps
Appendix E	Standard Operating Procedures – Sample Handling and Recordkeeping
Appendix F	Standard Operating Procedure – Decontamination
Appendix G	Quality Analytical Project Plan

This page intentionally left blank.

1.0 INTRODUCTION

Groundwater sampling will be performed on wells at the Red Hill Storage Facility (RHSF) in support of groundwater monitoring. The sampling will be performed on wells RHMW01 through -04, and 2254-01 (Figure 1-1) and the samples will be analyzed for petroleum-related constituents. The sampling will be completed with dedicated pumps, and is outlined below.

1.1 Pre-Sample Operations

1.1.1 Field Equipment

Field equipment that will be used during groundwater field activities for monitoring purposes include:

- Field sampling plan;
- Dedicated field notebook;
- Indelible ink pen;
- Flashlight;
- 15/16 socket and ratchet;
- Large adjustable wrench;
- Photo-ionization detector (PID);
- Controller box and fittings;
- 200 feet of 120V extension cord;
- 2 58-cf cylinders of compressed nitrogen and regulator;
- A water quality analyzer monitoring pH, specific conductivity and temperature;
- Water analytical cell, (flow through or grab sample cell);
- Field forms;
- Trash bags, paper towels, handi-wipes;
- Laboratory sample containers;
- Disposable 0.45 micron high capacity filters with hose barbs;
- Tygon tubing 3/8" ID and 1/4" ID;
- Sample labels, chain of custody forms, custody seals;
- Disposable nitrile gloves, hearing protection, eye protection, 1st aid kit;
- 5-gallon purge bucket (marked in 1/4 gallon increments);
- A dedicated sampling pump and associated equipment at each well.

The water quality analyzer will be calibrated daily according to manufacturer's guidelines and procedures for each item of equipment stated.

1.1.2 Pre-Sample Operations

Prior to sampling, the well caps will be removed and the organic vapor concentration at the top of well bore will be measured. The organic vapor content in the well will be measured with a PID. The sample line of the PID will be inserted into the top of the well and the

display of the PID will be monitored until the display stabilizes. The highest reading of the PID will be recorded on the Groundwater Sampling Log data sheet found in Appendix B. Water level and total depth should not be collected with dedicated pumps installed. The monitoring well construction information is presented in Table 1-1.

Table 1-1. Monitoring Well Construction Information

1.1.3 Purging Prior to Sampling

Wells will be sampled using dedicated pump systems. This system will require a source of clean, dry compressed air. It is recommended that nitrogen be used (available through Airgas Gaspro Hawaii in cylinders). Compressed air should not exceed 300 psi at the controller box. A 300 psi regulator is recommended to ensure that equipment is not damaged (it is provided with the controller system). Although a compressor is often available in the lower access tunnel, the moisture may damage the controller box. The compressed gas pressure will be reduced to <300 psi by use of a regulator with gages reading tank pressure and outlet pressure attached to the cylinder. One 58 cubic foot (cf) cylinder will purge all shallow wells (2254-01, RHMW01, RHMW02, RHMW03). RHMW04 may require 150 cf to purge. The controller box is electrically powered and runs on 120 alternating current (AC) voltage or 12 direct current (DC) voltage. The Geocontroller 2 will be connected to the dedicated bladder pumps. Operation of the bladder pumps are described in Appendix D.

Table 1-2 lists the pump specifications and controller box settings for each well. Prior to collecting a groundwater sample, the in situ groundwater in each monitoring well will be removed, or purged via a dedicated bladder pump fitted with dedicated Teflon lined polyethylene tubing. The purge water will be disposed in the RHSF oil/water separator system.

Measurements of field parameters is required to determine when sampling can occur (i.e., low flow conditions have allowed representative groundwater within the well as evidenced by stable parameters). The field parameters are measured with water quality meters; these meters should be calibrated daily and/or per manufacturer's instructions. The field parameters such as pH, temperature and specific conductivity will be measured using a water quality analyzer and recorded at approximate three minute intervals on a Groundwater Sampling Log data sheet (Appendix B) . Purging shall be considered complete when field parameter measurements (i.e.: pH, conductivity, temperature.) stabilize within approximately 10% of the last three consecutive recorded measurements.

Table 1-2 Groundwater Sampling Pump Requirement

Well	RHMW01	RHMW02	RHMW03	RHMW04	2254-01
Sampling Method	Dedicated pump	Dedicated pump	Dedicated pump	Dedicated pump	Dedicated pump
Pump Model	GEO850.SS 24	GEO1.66SS36			
Location	Lower Tunnel, South of Tank 1	Lower Tunnel, North of Tank 6	Lower Tunnel, North of Tank 14	Access Rd, South of Navy Firing Range	Lower Tunnel, Near Adit 3
dtw (ft)	82	84	101	293	81
Controller Pressure (psi)	50	70	80	190	55
Charge Time (s)	11	12	10	25	13
Exhaust Time (s)	5	10	15	22	12
Discharge Volume per Cycle (gal.)	0.012	0.09	0.11	0.09	0.09
Purge Requirements	Stable Parameters or 2.2 gal	Stable Parameters or 6.6 gal	Stable Parameters or 8 gal	Stable Parameters or 25 gal	Stable Parameters or 2.9 gal

dtw - depth to water

psi - pounds per square inch

s – seconds

gal - gallons

Figure 1-1 Groundwater Sampling Locations

2.0 SAMPLE COLLECTION

Immediately following purging, each monitoring well will be sampled. Table 2-1 lists the analyses and types of samples to be collected. Table 2-2 lists the samples containers and preservatives for each analysis. The field sampling log form to be used is provided in Appendix B. Information regarding analyses is presented in Table 2-1. All wells will be sampled directly from the dedicated bladder pumps systems. The analyses include volatile organic compounds (VOCs) by EPA Method 8260, total petroleum hydrocarbons (TPH) in the gasoline and diesel carbon ranges (-GRO and -DRO, respectively) by EPA Method 8015M, polynuclear aromatic hydrocarbons (PAHs) by EPA Methods 8270C SIMS, and total dissolved lead by EPA Method 6010B.

The sampler will don clean, nitrile protective gloves before collecting groundwater samples. Samples for volatile constituents (i.e., "VOCs" and "TPH-GRO") will be collected first, and placed directly into the 40-milliliter glass vials with septum-lined lids. A meniscus will be present, and the cap placed on, so that no headspace or bubbles are present in the container. Semi-volatile constituents (i.e., "PAHs" and "TPH-DRO") will be collected next, being placed directly into laboratory-supplied containers. Dissolved lead samples will be filtered in the field using a **0.45 micron filter** and placed in preserved (HNO₃) 500 mL polyethylene bottle. Note that filters will require a disposable barb fitting and tygon tubing (3/8" ID and 1/4" ID) to attach to the outlet hose of the dedicated pumps. The tygon tubing should go over the discharge line and go over the barb fitting attached to the .45 micron filter.

Sample containers will be labeled with the project name, location, sample identification number, date, time, type of analysis, and sampler's name. Samples will be protected from damage with adequate cushioning material (i.e., bubble wrap). The containers will then be placed on ice in sample coolers and transported under chain-of-custody procedures to the certified laboratory for analysis. Groundwater samples will be labeled and documented in accordance with SOPs presented in Appendix E, and as described in Section 3.

2.1 Trip Blank

The trip blank consists of a VOC sample vial filled in the laboratory with de-ionized water, transported to the sampling site, handled like an environmental sample and returned to the laboratory for analysis. Trip blanks are not opened in the field. Trip blanks are prepared only when VOC samples are taken and are analyzed only for VOC analytes. Trip blanks are used to assess the potential introduction of contaminants from sample containers or during the transportation and storage procedures. One trip blank will accompany each cooler of samples sent to the laboratory for analysis of VOCs (Table 2-1).

2.2 Field Duplicates

A field duplicate sample is a second sample collected at the same location as the original sample. Duplicate samples are collected simultaneously or in immediate succession, using identical recovery techniques, and treated in an identical manner during storage, transportation, and analysis. The sample containers are assigned an identification number

in the field such that they cannot be identified (blind duplicate) as duplicate samples by laboratory personnel performing the analysis. Specific locations are designated for collection of field duplicate samples prior to the beginning of sample collection. Monitoring wells with a history of contamination are usually chosen as duplicate sample locations.

Duplicate sample results are used to assess precision of the sample collection process. Precision of groundwater samples will be determined for all laboratory analyses. The frequency of collection for field duplicates is specified in Table 2-1.

2.3 Matrix Spike/Matrix Spike Duplicate

A matrix spike (MS) and a matrix spike duplicate (MSD), or MS/MSD is an aliquot of sample spiked with known concentrations of all target analytes. Monitoring wells without a history of contamination are usually chosen as MS/MSD sample locations. The spiking occurs in the laboratory prior to sample preparation and analysis. To ensure that the laboratory has enough sample to perform the analyses, two (2) to three (3) times the sample volume is collected, depending on individual laboratory requirements. The MS/MSD shall be designated on the chain of custody (e.g., 2/3 times volume for MS/MSD). The frequency of collection for MS/MSDs is specified in Table 2-1.

Table 2-1 Summary of Groundwater Sampling Analyses

Sample Description	Sample Type	Matrix	TPH-DRO 8015B	TPH-GRO 8015B	VOCs 8260B	SVOCs 8270C SIM	Dissolved Pb 6010B
RHMW01	N	GW	1	1	1	1	1
RHMW02	N	GW	1	1	1	1	1
RHMW03	N	GW	1	1	1	1	1
RHMW04	N	GW	1	1	1	1	1
RHMW2254-01	N	GW	1	1	1	1	1
Totals - Environmental samples			5	5	5	5	5
QC Samples							
Duplicates (RHMWA01)	FD	WQ	1	1	1	1	1
Trip Blanks	TB	WQ	-	-	1	-	-
MS/MSD (RHMW2254-01)	MS/MSD	WQ	1	1	1	1	1
Total QC samples			2	2	3	2	2

FD = Field duplicate

TB = Trip Blank

MS/MSD = Matrix Spike/Matrix Spike Duplicate

Table 2-2 Summary of Groundwater Sampling Containers, Preservatives and Hold Times

Name	Analytical Methods	Container ^a	Preservation ^b	Minimum Sample Volume or Weight	Maximum Holding Time
Total petroleum hydrocarbons (TPH)-volatile	SW8015P or SW8015E (modified)	G, Teflon®-lined septum	4°C, HCl to pH < 2	2 x 40 mL	14 days; 7 days if unpreserved by acid
Total petroleum hydrocarbons (TPH)-extractable	SW8015 (modified)	G, amber	4°C	1 liter	7 days until extraction and 40 days after extraction
Volatile organics	SW8260B	G, Teflon®-lined septum	4°C, 0.008% Na ₂ S ₂ O ₃ (HCl to pH < 2 for volatile aromatics by SW8260)	2 x 40 mL	14 days; 7 days if unpreserved by acid
Polynuclear aromatic hydrocarbons (PAHs)	8270 SIM	G, Teflon®-lined cap	4°C, store in dark, 0.008% Na ₂ S ₂ O ₃	1 liter	7 days until extraction and 40 days after extraction
Dissolved lead	6010B	P, G	HNO ₃	500mL	28 days after preservation at the lab

a. Polyethylene (P); glass (G).

b. Preservation with 0.008 percent Na₂S₂O₃ is only required when residual chlorine is present.

This page intentionally left blank.

3.0 SAMPLE DOCUMENTATION AND HANDLING

3.1 Field Logbook

The field logbook serves as the primary record of field activities. Entries shall be made chronologically and in sufficient detail to allow the writer or a knowledgeable reviewer to reconstruct the applicable events. The field logbook shall be bound with consecutively numbered and water repellent pages. The logbook shall be stored in a clean location and used only when outer gloves used for personal protective equipment have been removed. The logbook procedures will conform to SOP III-D in the *Project Procedures Manual* (PACDIV 1998). These procedures are presented in Appendix E and briefly outlined below.

Individual data forms may be generated to provide systematic data collection documentation. Entries on these forms shall meet the same requirements as entries in the logbook. At a minimum, names of all samples collected shall be included in the logbook even if recorded elsewhere.

At a minimum, the following information will be recorded in either the field logbook or a separate sample log sheet during the collection of each sample:

- Sample location and description;
- Sampler's name(s);
- Date and time of sample collection;
- Type of sample (groundwater, soil, or soil vapor);
- Type of sampling equipment used;
- Field instrument readings and calibration; and
- Field observations and details related to analysis or integrity of samples (e.g., weather conditions, noticeable odors, colors, etc.).
- In addition to the sampling information, the following specific information will also be recorded in the field logbook for each day of sampling;
- Time of arrival/entry on site and time of site departure;
- Other personnel on site;
- Summary of any meetings or discussions with regulators, contractor, or federal agency personnel;
- Deviations from sampling plans, site safety plans, and QC procedures; and
- Changes in personnel and responsibilities with reasons for the changes.

3.2 Sample Management

The integrity of data obtained for samples collected in the field depends on adherence to proper procedures for sample management involving both proper labeling and handling of samples. To ensure proper labeling and handling, sampling activities will be carried out according to PACDIV CLEAN SOP Number III-E, *Record Keeping, Sample Labeling, and Chain-of-Custody* (PACDIV 1998) and PACDIV CLEAN SOP Number III-F, *Sample*

Handling, Storage, and Shipment (PACDIV 1998). These procedures are presented in Appendix E and briefly outlined below.

3.2.1 Sample Logs, Labeling, and Chain-of-Custody

Detailed entries for logging and identifying samples and chain-of-custody (COC) procedures will be used to document acceptability of data generated. To minimize possibility of error, the number of personnel assuming custody for a sample will be minimized. Sample documentation and custody procedures will include completion of sample labels and COC forms for all samples. COC forms will typically serve as analytical request forms to a receiving laboratory.

The label for each field sample will contain the following information:

- unique sample number
- project name
- location, time, and date of collection
- name of sampler(s)
- type of analysis

A preprinted COC form will accompany samples from their time of collection and processing in the field through submittal to a particular testing laboratory. The COC form will trace and document the path of each individual sample by means of a unique COC identification number. The following information will be included on a COC form:

- project name (Red Hill)
- sampling location, date, and time
- sample identification
- number of unique sample containers for a sample
- type of sample containers
- sample preservative (if any)
- number of samples addressed on the COC form
- type of analysis required for each sample
- special instructions (if any)
- signatures indicating sample relinquishment and receipt

COC forms that accompany the samples during shipment to a designated testing laboratory will be placed in a sealed plastic bag and taped to the inside of the shipping container. To document the transfer of samples from the field to a receiving laboratory, a representative of the receiving laboratory will sign the accompanying COC form upon arrival of the shipping container at the laboratory. All samples will be shipped from the field to a receiving laboratory by Federal Express or equivalent carrier. Facsimiles of COC forms will be submitted to a laboratory and the project manager within 24 hours of each sample shipment.

3.2.2 Project-Specific Sample Identifier

A unique Project-Specific Sample Identifier will be assigned to each normal sample. This identifier will use the following format of “aabbcc-ddee.”

aa	=	two-letter acronym designating a specific CTO site (RH = Red Hill)
bb	=	location acronym (e.g., MW for monitoring well)
cc	=	location number (e.g., 01 for monitoring well MW01-)
dd	=	matrix type (e.g., GW for groundwater)
ee	=	sequential sampling round number (e.g., 01, 02, 03)

An example of the Project-Specific Sample Identifier for this project might be RHMW01-GW06.

A unique Project-Specific Normal Sample Identifier will be assigned to each duplicate sample. This identifier will use the following format of “aabbccc-ddee.”

aa	=	two-letter acronym designating a specific CTO site (RH = Red Hill)
bb	=	location acronym (e.g., MW for monitoring well)
ccc	=	location number (e.g., A01- for duplicates in chronological order)
dd	=	matrix type (e.g., GW for groundwater)
ee	=	sequential sampling round number (e.g., 01, 02, 03)

An example of the Project-Specific Duplicate Sample Identifier for this project might be RHMWA01-GW06. Field duplicate samples will be given a designated sampling time of 1205.

A unique Project-Specific Sample Identifier will be assigned to each trip blank sample. This identifier will use the following format of “aabb-ccdd.”

aa	=	two-letter acronym designating a trip blank sample (TB = Trip Blank)
bb	=	chronological trip blank number (e.g., 01-)
cc	=	matrix type (e.g., GW for groundwater)
dd	=	sequential sampling round number (e.g., 01, 02, 03)

An example of the Project-Specific Trip Blank Identifier for this project might be TB01-GW06. Trip Blank samples will be given a designated sampling time of 0805.

The eight to eleven-character Project-Specific Sample Identifier establishes a unique sample identifier that can be used in reports, tables, figures, etc. A great deal of information is contained in the name that makes it meaningful. The Project-Specific Sample Identifier will be entered into the COC logbooks (see Appendix E, PACDIV CLEAN SOP Number III-E, *Record Keeping, Sample Labeling, and Chain-of-Custody* [PACDIV 1998]) so that the database can be used to track samples by Project-Specific Sample Identifier.

3.2.3 Sample Handling, Storage, and Transport

Sample handling during all phases of sample collection, transport, and receipt by laboratories will be performed according to the requirements of PACDIV CLEAN SOP Number III-F, *Sample Handling, Storage, and Shipping* (PACDIV 1998) presented in Appendix E. All Department of Transportation (DOT) regulations will be followed for packaging and shipment of samples, as described in PACDIV CLEAN SOP Number III-F. Formal training in shipping hazardous materials is required prior to shipping samples that could potentially contain hazardous materials.

Glass containers for shipping of chemistry samples will be wrapped in bubble wrap or other appropriate protection to prevent breakage during shipment. As appropriate, styrofoam will be placed on the bottom and top of the inside of shipment coolers. Styrofoam peanuts also may be used to fill spaces between containers in coolers. An appropriate absorbent material will be added to coolers on the bottom and top to absorb any water, act as cushioning material, and absorb any sample material that may leak or otherwise spill due to breakage.

All samples will be kept in insulated coolers with ice, or taken to a secured location and transferred from the insulated cooler with blue-ice to a refrigerator or freezer (as appropriate) until shipment. If a nearby refrigerator or freezer for storage is not available, dry ice may be used to keep blue-ice blocks frozen onsite. Fresh, frozen blue-ice blocks will be repacked with samples prior to shipment. COC forms will be placed inside sealable storage plastic bags and placed inside sample coolers. Coolers will then be closed and sealed with waterproof tape, and lids will be sealed with two custody seals to enable detection of tampering during shipment. Coolers will be delivered to the appropriate shipping courier or office (i.e., Federal Express or equivalent carrier).

4.0 DECONTAMINATION AND INVESTIGATIVE DERIVED WASTE

4.1 Equipment Decontamination

Decontamination of sampling equipment will be performed to ensure data quality, to prevent cross-contamination, and to prevent the potential introduction of contaminants into previously un-impacted areas. Non-disposable sampling equipment will be decontaminated between samples in accordance with procedure I-F, *Equipment Decontamination* (PACDIV 1998), presented in Appendix F.

Since dedicated pumps are being used, only parameter monitoring equipment such as probes to monitor dissolved oxygen, pH, conductivity, and temperature, also require decontamination. Since the probes on these type of equipment are sensitive and operate in a limited range, they should be decontaminated between samples by rinsing three times with tap water. They should also be stored with the probes in the correct solution as required by the manufacturer (i.e., pH 4 solution for the pH probe, etc.). Decontamination liquids and rinsate will be placed in the onsite oil/water separator disposal system. Onsite sampling personnel will perform decontamination procedures prior to leaving the site.

4.2 Investigative Derived Waste

Investigative Derived Waste (IDW) generated during groundwater sampling may include the following media and waste types:

- Groundwater monitoring well purge water
- Decontamination fluids
- Personal protective equipment (PPE)
- Disposable equipment (DE)

PPE may include, but are not limited to, the following:

- Tyvek suits
- Nitrile gloves
- Eye Protection
- Hearing Protection
- Work Boots

DE may include, but are not limited to, the following:

- Plastic sheeting (visqueen)
- Pump hoses and discharge lines
- Paper towels
- Sample filters

Purged water will be placed in 5-gallon buckets for immediate containment. The drum contents will be discharged to the drains of the onsite oil/water separator system. No fluids

containing soaps or surfactants may be placed into the oil/water separator system. PPE and DE will be placed in plastic trash bags and disposed of as solid waste in a landfill. Contaminated PPE and DE will be cleaned prior to disposal.

This page intentionally left blank.

Date: August 2007

Appendix A – Installation of Dedicated Equipment

This page intentionally left blank.

Date: August 2007

During the life-time of the dedicated pumps, it may be necessary to remove and install the pumps as part of servicing or replacement. The following sections provide information regarding the installation of the pumps. When the pumps are removed from the wells, care should be taken so that all of the related equipment is placed on a new, plastic-lined surface, (never on the ground), to avoid any potential contamination.

A.1 Installation of Dedicated Pumps

Dedicated sampling pumps will be installed in five wells (RHMW01 through -04 and 2254-01) at the Red Hill Storage Facility (RHSF). Table A-1 lists the well design specifications and the pump model to be installed in each well. The pumps will be ordered pre-fabricated to a tubing length to ensure the pump suction remains below the water table throughout the expected range of water elevations in these wells. Installation will consist of unpacking the pump assemblies, opening the monitoring wells, decontamination of pump assemblies, installation of the pump assemblies in the wells, and testing the pumps.

Table A-1 Pump Installation Summary

Well Data/ID	RHMW01	RHMW02	RHMW03	RHMW04	2254-01
Well Depth	100	103	118	320	120
Well Diameter	1-inch	2-inch	2-inch	4-inch	2-inch
Pump Model	GEO850.SS24	GEO1.66SS36			

It is extremely important that accurate distances between the well top of casing and the lowest expected water level be known before ordering the pump assembly packages. The tubing lengths should be long enough so that the top of the pump is just beneath the water when the water table is at the lowest expected elevation. This elevation could be estimated by comparing current water levels in the monitoring wells selected for pump installation with long term water level data from the Moanaula Monitoring Well, (well number 2153-09) and the Halawa Deep Monitoring Well (well number 2255-33). Water levels during the drought years of 1998 through 2001 will be extremely helpful for this assessment.

A.2 Unpacking Pump Assemblies

Sheet plastic shall be laid down prior to opening the packages to prevent contaminating the pumps and hosing. Care shall be taken so the tubing is not damaged when opening the package. An inventory shall be taken immediately upon opening the packages to ensure all parts are present.

Date: August 2007

A.3 Opening the Monitoring Wells

Prior to unlocking or removing the cover for the wells, the area around the well shall be clean to prevent the introduction of debris into the well. Immediately after opening the vapor cap on the well a PID measurement inside well bore will be taken and recorded. After the PID reading is taken, the depth to water level and depth to bottom of the well screen will be taken.

A.4 Decontamination of Pump Assemblies

Prior to installation of the pump assemblies into the well, all pumps and tubing will be cleaned in accordance with Appendix F, Standard Operating Procedures, Decontamination, of the Red Hill Bulk Fuel Storage Facility Work Plan (TEC 2005) to prevent the introduction of contamination into the well.

A.5 Installation of the Pump Assemblies in the Wells

Installation of the pumps are described in Geotech's Bladder Pumps Installation and Operations Manual. This document can be found in Appendix D of the this document.

A.6 Testing the Pumps

The pumps are bladder pumps that operate with compressed air. Inside of the RHFSF tunnel compressed air is currently available. An air line from the Geocontroller 2 will be connected to air service line and to the pump. For wells RHMW04 and 2254-01 a compressed gas bottle containing either clean and dry nitrogen or carbon dioxide will be used to power the pumps. A regulator will be used to ensure that the pressure to the pump controller does not exceed 125 pounds per square inch (psi). The Geocontroller 2 will be used with all pumps. The specific operating procedures for each piece of equipment are listed below and presented at the end of this section:

- When working with compressed air always wear eye protection and secure compressed air hoses.
- Do not disable the pneumatic pumps when they are connected to compressed air.
- Do not pump sand with these bladder pumps as this will damage the bladder.
- Operating pressure is 0.5 estimated by:
 - $\text{PSI operating} = \frac{1}{2}(\text{dtw}) + 10\text{PSI}$,
where
 - PSI operating is the expected operating pressure needed, dtw is the depth to water from the controller box, 10PSI is added to overcome the friction.

Date: August 2007

Appendix B - Groundwater Sampling Forms

Date: August 2007

This page intentionally left blank.

Red Hill FIELD SAMPLING LOG

(Groundwater)

GROUNDWATER SAMPLE INFORMATION

Matrix: <u>GW</u>	Sample ID: <u>RHMW01</u>
Sampling Method: <u>Geotech Bladder Pump</u>	DUP./REP. OF: _____
Purge Method: <u>Geotech Bladder Pump</u>	Matrix Spike/Matrix Spike Duplicate
Sample Date: _____	Sample Time: _____ Yes: _____ No: _____

GROUNDWATER PARAMETERS

CONTAINER			PRESERVATIVE/ PREPARATION	EXTRACTION METHOD	ANALYTICAL METHOD	CONSTITUENT DESCRIPTION	ANALYZE FOR? (Y/N)
SIZE	TYPE	#					
40 ml	VOA	3	4° HCl to pH<2		8260	VOCs	
40 ml	VOA	3	4° HCl to Ph<2		8015M GRO	TPH Gasoline	
1 L	AMB	2	4° H ₂ SO ₄ to pH <2		8015M DRO	TPH Diesel	
1 L	AMB	2	4°		8270-SIM	PAHs	
500 ml	POLY	1	4° HNO ₃ TO Ph<2, Field Filtered		6010B	Lead (Dissolved)	

NOTABLE OBSERVATIONS

PID READINGS	SAMPLE CHARACTERISTICS	MISCELLANEOUS
1 st	H ₂ O Level:	
2 nd	Color:	
	Odor:	
	Other:	

FIELD TESTS

pH : _____	Dissolved Oxygen (mg/L) : _____
Temp. °C : _____	Nitrate/Nitrite (mg/L) : _____
Conductivity (μseimen) : _____	Sulfate (mg/L) : _____
Turbidity (FAU) : _____	Alkalinity (mg/L) : _____

GENERAL INFORMATION

WEATHER: SUN/CLEAR _____ CLOUDY/RAIN _____ WIND DIRECTION _____ TEMPRATURE (°C) _____

SHIPMENT VIA: FED-X _____ HAND DELIVER _____ COURIER _____ OTHER _____

SHIPPED TO: _____

COMMENTS: _____

SAMPLER: _____ OBSERVER: _____

Well Development / Purge Log

Location: Lower Access Tunnel South of T1				Station Name: RHMW01				Date:			
Sample Pump: Geol 66SS36				Elevation: 102.51				Time			
Controller: Geoccontroller 2				Dry: yes no				Start:			
PSI: 50				Charge (s): 11				Water Quality Device:			
Water Level (FTOC)				Volume Removed (gal)				Exhaust (s): 5			
EC (µS/cm)				Turbidity (FAU)				Purge Method: Low Flow Parameter Stability			
pH				Temp °C				Water Quality Device:			
Color				Comments				3-Well Volumes			
EC (µS/cm)				Comments				Well Casing Volume			
Turbidity (FAU)				Comments				3 Well Casing Volumes			
Comments				Comments				Pump Hose Volume			
Comments				Comments				Pump Cycle Time			
Comments				Comments				Pump Cycle Volume			
Comments				Comments				Hose Purge Time			
Comments				Comments				80 sec			

Casing Volume Information		
A Hole Diam.	=	2 in
B Casing OD	=	1.5 in
C Casing ID	=	1 in
D H2O Level	=	82 ft
E TD	=	100 ft
F Est. Filter Porosity	=	0.4

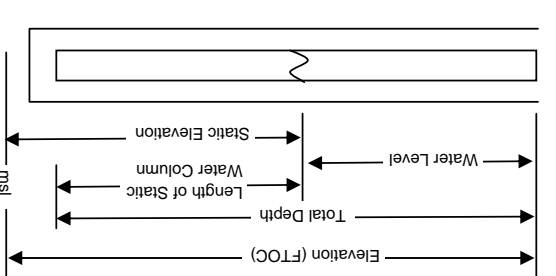

Casing ID	VOL Gal/Ft
1.00	0.04
1.50	0.09
2.00	0.16
2.50	0.26
3.00	0.37
3.50	0.50
4.00	0.65
4.50	0.83
6.00	1.50
7.00	2.00
8.00	2.60

Notes:

Red Hill FIELD SAMPLING LOG

(Groundwater)

GROUNDWATER SAMPLE INFORMATION

Matrix: <u>GW</u>	Sample ID: <u>RHMW02</u>
Sampling Method: <u>Geotech Bladder Pump</u>	DUP./REP. OF: _____
Purge Method: <u>Geotech Bladder Pump</u>	Matrix Spike/Matrix Spike Duplicate
Sample Date: _____	Sample Time: _____ Yes: _____ No: _____

GROUNDWATER PARAMETERS

CONTAINER			PRESERVATIVE/ PREPARATION	EXTRACTION METHOD	ANALYTICAL METHOD	CONSTITUENT DESCRIPTION	ANALYZE FOR? (Y/N)
SIZE	TYPE	#					
40 ml	VOA	3	4° HCl to pH<2		8260	VOCs	
40 ml	VOA	3	4° HCl to Ph<2		8015M GRO	TPH Gasoline	
1 L	AMB	2	4° H ₂ SO ₄ to pH <2		8015M DRO	TPH Diesel	
1 L	AMB	2	4°		8270-SIM	PAHs	
500 ml	POLY	1	4° HNO ₃ TO Ph<2, Field Filtered		6010B	Lead (Dissolved)	

NOTABLE OBSERVATIONS

PID READINGS	SAMPLE CHARACTERISTICS	MISCELLANEOUS
1 st	H ₂ O Level:	
2 nd	Color:	
	Odor:	
	Other:	

FIELD TESTS

pH : _____	Dissolved Oxygen (mg/L) : _____
Temp. °C : _____	Nitrate/Nitrite (mg/L) : _____
Conductivity (μseimen) : _____	Sulfate (mg/L) : _____
Turbidity (FAU) : _____	Alkalinity (mg/L) : _____

GENERAL INFORMATION

WEATHER: SUN/CLEAR _____ CLOUDY/RAIN _____ WIND DIRECTION _____ TEMPRATURE (°C) _____

SHIPMENT VIA: FED-X _____ HAND DELIVER _____ COURIER _____ OTHER _____

SHIPPED TO: _____

COMMENTS: _____

SAMPLER: _____ OBSERVER: _____

Red Hill FIELD SAMPLING LOG

(Groundwater)

GROUNDWATER SAMPLE INFORMATION

Matrix: <u>GW</u>	Sample ID: <u>RHMW03</u>
Sampling Method: <u>Geotech Bladder Pump</u>	DUP./REP. OF: _____
Purge Method: <u>Geotech Bladder Pump</u>	Matrix Spike/Matrix Spike Duplicate
Sample Date: _____	Sample Time: _____ Yes: _____ No: _____

GROUNDWATER PARAMETERS

CONTAINER			PRESERVATIVE/ PREPARATION	EXTRACTION METHOD	ANALYTICAL METHOD	CONSTITUENT DESCRIPTION	ANALYZE FOR? (Y/N)
SIZE	TYPE	#					
40 ml	VOA	3	4° HCl to pH<2		8260	VOCs	
40 ml	VOA	3	4° HCl to Ph<2		8015M GRO	TPH Gasoline	
1 L	AMB	2	4° H ₂ SO ₄ to pH <2		8015M DRO	TPH Diesel	
1 L	AMB	2	4°		8270-SIM	PAHs	
500 ml	POLY	1	4° HNO ₃ TO Ph<2, Field Filtered		6010B	Lead (Dissolved)	

NOTABLE OBSERVATIONS

PID READINGS	SAMPLE CHARACTERISTICS	MISCELLANEOUS
1 st	H ₂ O Level:	
2 nd	Color:	
	Odor:	
	Other:	

FIELD TESTS

pH : _____	Dissolved Oxygen (mg/L) : _____
Temp. °C : _____	Nitrate/Nitrite (mg/L) : _____
Conductivity (μseimen) : _____	Sulfate (mg/L) : _____
Turbidity (FAU) : _____	Alkalinity (mg/L) : _____

GENERAL INFORMATION

WEATHER: SUN/CLEAR _____ CLOUDY/RAIN _____ WIND DIRECTION _____ TEMPRATURE (°C) _____

SHIPMENT VIA: FED-X _____ HAND DELIVER _____ COURIER _____ OTHER _____

SHIPPED TO: _____

COMMENTS: _____

SAMPLER: _____ OBSERVER: _____

Red Hill FIELD SAMPLING LOG

(Groundwater)

GROUNDWATER SAMPLE INFORMATION

Matrix: <u>GW</u>	Sample ID: <u>RHMW04</u>
Sampling Method: <u>Geotech Bladder Pump</u>	DUP./REP. OF: _____
Purge Method: <u>Geotech Bladder Pump</u>	Matrix Spike/Matrix Spike Duplicate
Sample Date: _____	Sample Time: _____ Yes: _____ No: _____

GROUNDWATER PARAMETERS

CONTAINER			PRESERVATIVE/ PREPARATION	EXTRACTION METHOD	ANALYTICAL METHOD	CONSTITUENT DESCRIPTION	ANALYZE FOR? (Y/N)
SIZE	TYPE	#					
40 ml	VOA	3	4° HCl to pH<2		8260	VOCs	
40 ml	VOA	3	4° HCl to Ph<2		8015M GRO	TPH Gasoline	
1 L	AMB	2	4° H ₂ SO ₄ to pH <2		8015M DRO	TPH Diesel	
1 L	AMB	2	4°		8270-SIM	PAHs	
500 ml	POLY	1	4° HNO ₃ TO Ph<2, Field Filtered		6010B	Lead (Dissolved)	

NOTABLE OBSERVATIONS

PID READINGS	SAMPLE CHARACTERISTICS	MISCELLANEOUS
1 st	H ₂ O Level:	
2 nd	Color:	
	Odor:	
	Other:	

FIELD TESTS

pH : _____	Dissolved Oxygen (mg/L) : _____
Temp. °C : _____	Nitrate/Nitrite (mg/L) : _____
Conductivity (μseimen) : _____	Sulfate (mg/L) : _____
Turbidity (FAU) : _____	Alkalinity (mg/L) : _____

GENERAL INFORMATION

WEATHER: SUN/CLEAR _____ CLOUDY/RAIN _____ WIND DIRECTION _____ TEMPRATURE (°C) _____

SHIPMENT VIA: FED-X _____ HAND DELIVER _____ COURIER _____ OTHER _____

SHIPPED TO: _____

COMMENTS: _____

SAMPLER: _____ OBSERVER: _____

Red Hill FIELD SAMPLING LOG

(Groundwater)

GROUNDWATER SAMPLE INFORMATION

Matrix: <u>GW</u>	Sample ID: <u>RHMW2254-01</u>
Sampling Method: <u>Geotech Bladder Pump</u>	DUP./REP. OF: _____
Purge Method: <u>Geotech Bladder Pump</u>	Matrix Spike/Matrix Spike Duplicate
Sample Date: _____	Sample Time: _____ Yes: _____ No: _____

GROUNDWATER PARAMETERS

CONTAINER			PRESERVATIVE/ PREPARATION	EXTRACTION METHOD	ANALYTICAL METHOD	CONSTITUENT DESCRIPTION	ANALYZE FOR? (Y/N)
SIZE	TYPE	#					
40 ml	VOA	3	4° HCl to pH<2		8260	VOCs	
40 ml	VOA	3	4° HCl to Ph<2		8015M GRO	TPH Gasoline	
1 L	AMB	2	4° H ₂ SO ₄ to pH <2		8015M DRO	TPH Diesel	
1 L	AMB	2	4°		8270-SIM	PAHs	
500 ml	POLY	1	4° HNO ₃ TO Ph<2, Field Filtered		6010B	Lead (Dissolved)	

NOTABLE OBSERVATIONS

PID READINGS	SAMPLE CHARACTERISTICS	MISCELLANEOUS
1 st	H ₂ O Level:	
2 nd	Color:	
	Odor:	
	Other:	

FIELD TESTS

pH : _____	Dissolved Oxygen (mg/L) : _____
Temp. °C : _____	Nitrate/Nitrite (mg/L) : _____
Conductivity (μseimen) : _____	Sulfate (mg/L) : _____
Turbidity (FAU) : _____	Alkalinity (mg/L) : _____

GENERAL INFORMATION

WEATHER: SUN/CLEAR _____ CLOUDY/RAIN _____ WIND DIRECTION _____ TEMPRATURE (°C) _____

SHIPMENT VIA: FED-X _____ HAND DELIVER _____ COURIER _____ OTHER _____

SHIPPED TO: _____

COMMENTS: _____

SAMPLER: _____ OBSERVER: _____

Red Hill FIELD SAMPLING LOG

(Groundwater)

GROUNDWATER SAMPLE INFORMATION

Matrix: <u>GW</u>	Sample ID: <u>RHMWA01</u>
Sampling Method: <u>Geotech Bladder Pump</u>	DUP./REP. OF: <u>RHMW</u>
Purge Method: <u>Geotech Bladder Pump</u>	Matrix Spike/Matrix Spike Duplicate
Sample Date: _____	Sample Time: _____ Yes: _____ No: _____

GROUNDWATER PARAMETERS

CONTAINER			PRESERVATIVE/ PREPARATION	EXTRACTION METHOD	ANALYTICAL METHOD	CONSTITUENT DESCRIPTION	ANALYZE FOR? (Y/N)
SIZE	TYPE	#					
40 ml	VOA	3	4° HCl to pH<2		8260	VOCs	
40 ml	VOA	3	4° HCl to Ph<2		8015M GRO	TPH Gasoline	
1 L	AMB	2	4° H ₂ SO ₄ to pH <2		8015M DRO	TPH Diesel	
1 L	AMB	2	4°		8270-SIM	PAHs	
500 ml	POLY	1	4° HNO ₃ TO Ph<2, Field Filtered		6010B	Lead (Dissolved)	

NOTABLE OBSERVATIONS

PID READINGS	SAMPLE CHARACTERISTICS	MISCELLANEOUS
1 st	H ₂ O Level:	
2 nd	Color:	
	Odor:	
	Other:	

FIELD TESTS

pH : _____	Dissolved Oxygen (mg/L) : _____
Temp. °C : _____	Nitrate/Nitrite (mg/L) : _____
Conductivity (μseimen) : _____	Sulfate (mg/L) : _____
Turbidity (FAU) : _____	Alkalinity (mg/L) : _____

GENERAL INFORMATION

WEATHER: SUN/CLEAR _____ CLOUDY/RAIN _____ WIND DIRECTION _____ TEMPRATURE (°C) _____

SHIPMENT VIA: FED-X _____ HAND DELIVER _____ COURIER _____ OTHER _____

SHIPPED TO: _____

COMMENTS: _____

SAMPLER: _____ OBSERVER: _____

Date: August 2007

This page intentionally left blank.

Date: August 2007

Appendix C – Geocontroller 2

Date: August 2007

This page intentionally left blank.

geotech

Geocontrol 2 Logic Unit

Installation and Operation Manual



Rev. 2 10/18/02 Part # 11150170

TABLE OF CONTENTS

Chapter 1: System Description	p. 03
Function and Theory.....	p. 03
Chapter 2: System Installation.....	p. 04
Chapter 3: System Operation	p. 05
Chapter 4: System Maintenance	p. 09
Chapter 5: System Troubleshooting.....	p. 10
Chapter 6: System Specifications.....	p. 11
Chapter 7: System Schematic	p. 12
Chapter 8: Replacement Parts List.....	p. 13
Warranty and Repair.....	p. 16

DOCUMENTATION CONVENTIONS

This manual uses the following conventions to present information:



WARNING

An exclamation point icon indicates a **WARNING** of a situation or condition that could lead to personal injury or death. You should not proceed until you read and thoroughly understand the **WARNING** message.



CAUTION

A raised hand icon indicates **CAUTION** information that relates to a situation or condition that could lead to equipment malfunction or damage. You should not proceed until you read and thoroughly understand the **CAUTION** message.



NOTE

A note icon indicates **NOTE** information. Notes provide additional or supplementary information about an activity or concept.

Chapter 1: System Description

Function and Theory

GEOTECH'S GEOCONTROL 2 utilizes advanced electronic logic to control both high rate purging and gentle low flow sampling. Simple to use accurate microprocessor controlled on/off timers are utilized to recreate expert techniques for low-flow sampling.

The GEOCONTROL 2 high-pressure solenoid activated valve delivers even in the deepest sampling applications.

The GEOCONTROL 2 can be used with any bladder pump system with the use of simple quick-disconnect adapters.

Chapter 2: System Installation



READ BEFORE PROCEEDING ANY FURTHER

THE GEOCONTROL 2 REQUIRES DRY MOISTURE FREE AIR. TO DISREGARD WILL INCREASE THE LIKELIHOOD OF UNNECESSARY MAINTENANCE!

Determine your power source, either 115 or 12VDC.

Selecting Air Source

The following explanation is based on the Geotech Bladder Pump Model GEO1.66SS36 with .170 ID air supply tubing. To determine the required capacity of the air source used, calculate the air consumption as follows. With 100 ft. of air line tubing in or out of the well, the air consumption is 125 cubic inches per cycle, with 6 cycles per minute (average).

Example: For 100 ft. of tubing you'd need 125 cu. in. x 6 per min. which equals 750 cu. in./ min. or 45,000 cu. in./ hr. For each additional 100 ft. add 59 cu. in.

If you plan to use an air compressor, we advise that you use one with a reserve tank to insure proper air supply to the pump. If you plan to use a Nitrogen Tank, see figure 2 for Nitrogen Tank Volume vs. Bladder Pump consumption.

Determining PSI

Determine the air pressure needed to operate the Bladder Pump based on the length of the air supply line to the pump (well depth). Use the simplified formula of (1/2 PSI per foot) + 10 PSI for friction.

Example: For a pump 100 ft. away from the air source, use 100 ft. divided by 2 then add 10 this equals 60 PSI ($100' / 2 + 10 = 60$ PSI).

The additional 10 PSI is to account for the pump itself and friction loss along the air line tubing.

Where the length of the air line to the Bladder Pump is 50 ft. or less, an additional 10 PSI need not be added.

Chapter 3: System Operation

To determine minimum operating pressures for the specific Bladder Pump model you are using, consult Pumps Specifications. Typically the minimum operating pressure will be 5 PSI above static head.

Example: Bladder Pump depth is 50 ft. $50 / 2 = 25 + 5 = 30$ PSI.

The formulas stated above are not absolute, and are meant to provide baseline information.

At the wellhead, connect the air supply line from the air source (compressor, bottle etc.) to the quick disconnect marked AIR INLET. (See section, selecting an air source) Next connect the air supply line hose whip to the airline at the well cap and the quick disconnect marked AIR OUTPUT, see figure 1.

Adjust the air source regulator to the appropriate psi, (see section on determining psi)

Switch the toggle from OFF to AC or DC depending on power supply selected.

ADJUSTING CYCLE TIMERS

Adjust Charge Time knob to approx. 5 seconds, adjust Exhaust Time knob to approx 15 seconds.

A 15 second exhaust cycle will be enough time to fill bladder at approx 100 ft.

The charge cycle can be adjusted by watching the sample line. When a steady stream of water stops, set the charge cycle back about one second.

DO NOT OVER CHARGE this will cause excessive bladder wear. Once the charge cycle is adjusted, measure the volume of the sample. Adjust the exhaust cycle back by one second at a time. Let the pump cycle a few times after each adjustment before adjusting again. Measure the volume of sample to make sure it is not decreasing. Continue to reduce the exhaust time back until the sample volume decreases. A decrease in sample volume indicates that the exhaust cycle isn't long enough for the pump bladder to fill to its maximum. Add one second to the exhaust cycle at this point to make sure the maximum volume in the bladder is achieved.

The GEOCONTROL 2 has a red indicator LED labeled POWER. When the red LED is constant the

The controller is in CHARGE TIME. When the red LED is blinking the controller is in EXHAUST TIME.

LOW FLOW SAMPLING

The GEOCONTROL 2 includes a flow control valve, marked EXHAUST FLOW. The flow control valve ensures a true low flow of the sample by controlling the speed, with which the bladder fills, regardless of the depth of the pump. Tightening the control knob clockwise will reduce the flow of the exhaust and slow the filling of the bladder. Turning the control knob counter-clockwise will increase the flow of exhaust thus increasing the speed of the flow of water into the bladder.

NITROGEN TANK VOLUME VS BLADDER PUMP CONSUMPTION

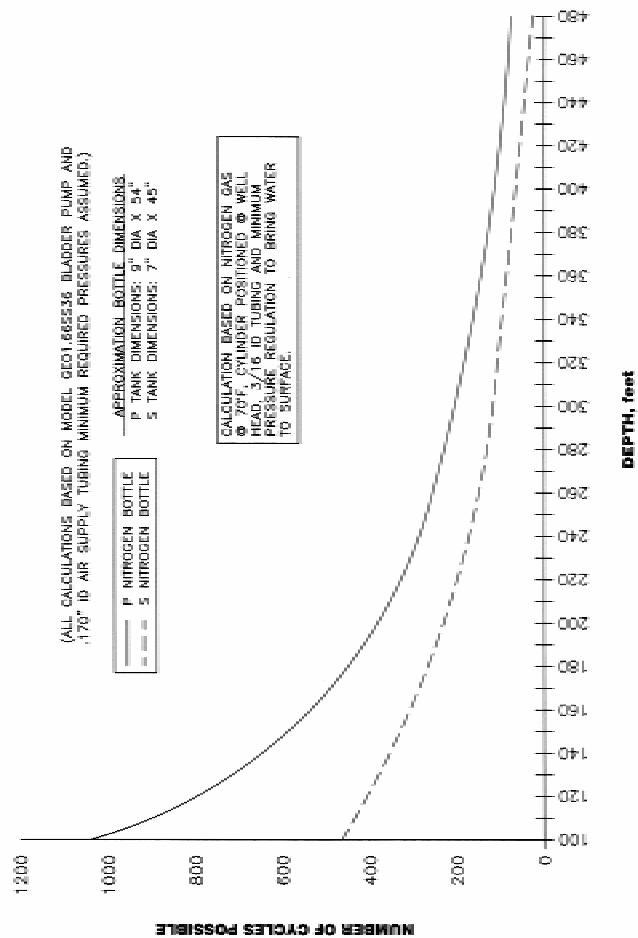

Figure 2 – Nitrogen Tank Volume vs. Bladder pump consumption

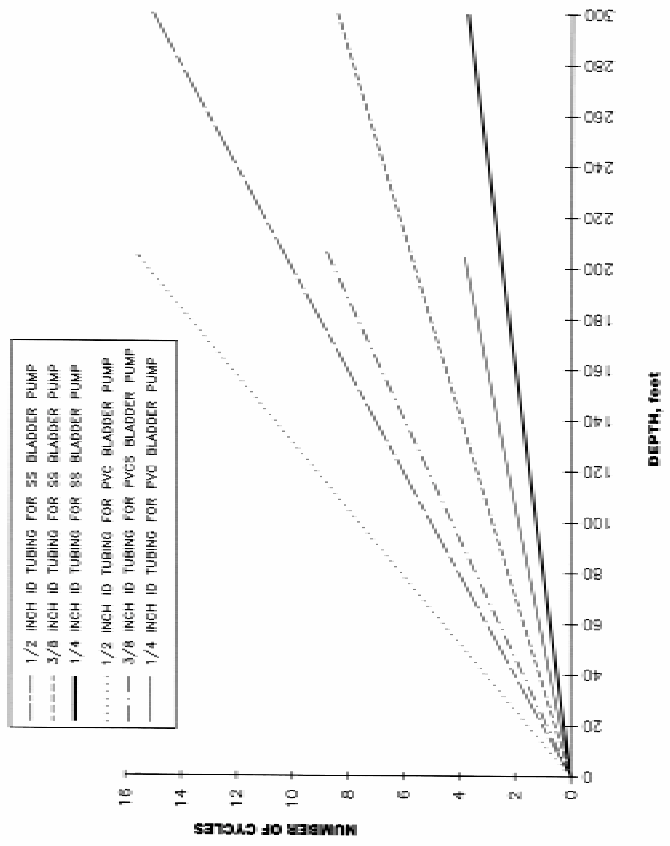

Figure 3 – Cycles vs. Depth

Chapter 4: System Maintenance

The GEOCONTROL 2 does not require a regular maintenance program.

As stated in installation and operation, this unit requires dry moisture free air. To disregard will increase the likelihood of unnecessary maintenance.

Chapter 5: System Troubleshooting

Problem:

Solutions:

*Unit will not turn on...
and make sure*

Check power source, cables for damage, if you are on DC it is a 12 volt DC source, if on AC that you are getting consistent 110 volt current.

*Unit turns on but cycles
rapidly, no pumping*

Charge and exhaust times not set correctly.
-Check and adjust charge and exhaust cycle times (i.e. if charge time too long and exhaust time too short, or charge time too short). Review Chapter 3 page 5 for correct cycle times.

*Turns on, cycles correctly but
does not pump water...*

-Check for tubing kinks
-Check psi on gauge, may be too low. Calculate based on .5 psi per foot of head and add 10 for friction.
- If psi is good, check your exhaust flow, may be completely shut, try turning three times to the left. (Exhaust is the brass valve).

*Unit was working but quit
cycling...*

-Check power source
-If power source is good, check air source
-Air source is good have you been using clean dry air? If not contact Geotech at 1-800-833-7958

Chapter 6: System Specifications

Model: Geocontrol 2

Maximum Ratings

Input DC Power Source	10.5-13.8	VDC
DC Current Draw	0.5	Amps
DC Input Surge Current	<50	Amps
Input AC Power Source	105-130	VAC
AC Current Draw	0.1	Amps
AC Input Surge Current	<15	Amps
Input AC Line Frequency	45-65	Hz
Maximum Power	15	Watts

Performance

Input Air Pressure	300	PSI
Operating Depth	0-690	Feet
* On Timer Range	0.125 to 30	Seconds
* Off Timer Range	0.125 to 30	Seconds
Timer Resolution	0.125	Seconds
Timer Accuracy	±0.125	Seconds

Environmental

Operating Temperature Range	0-70°	C
Storage Temperature Range	-20 to 85°	C
Position Effect	0.10% change at any angle	
Vibration	No change after 10G RMS 20 to 2000 Hz	
Shock	No change after 50Gs for 11ms	
EMI Emissions	Class A	

Physical

Enclosure	7 x 16 x 12	Inches
Weight	14	Pounds
Enclosure Material	Structural resin	

* Custom timer ranges available

Chapter 7: System Schematic

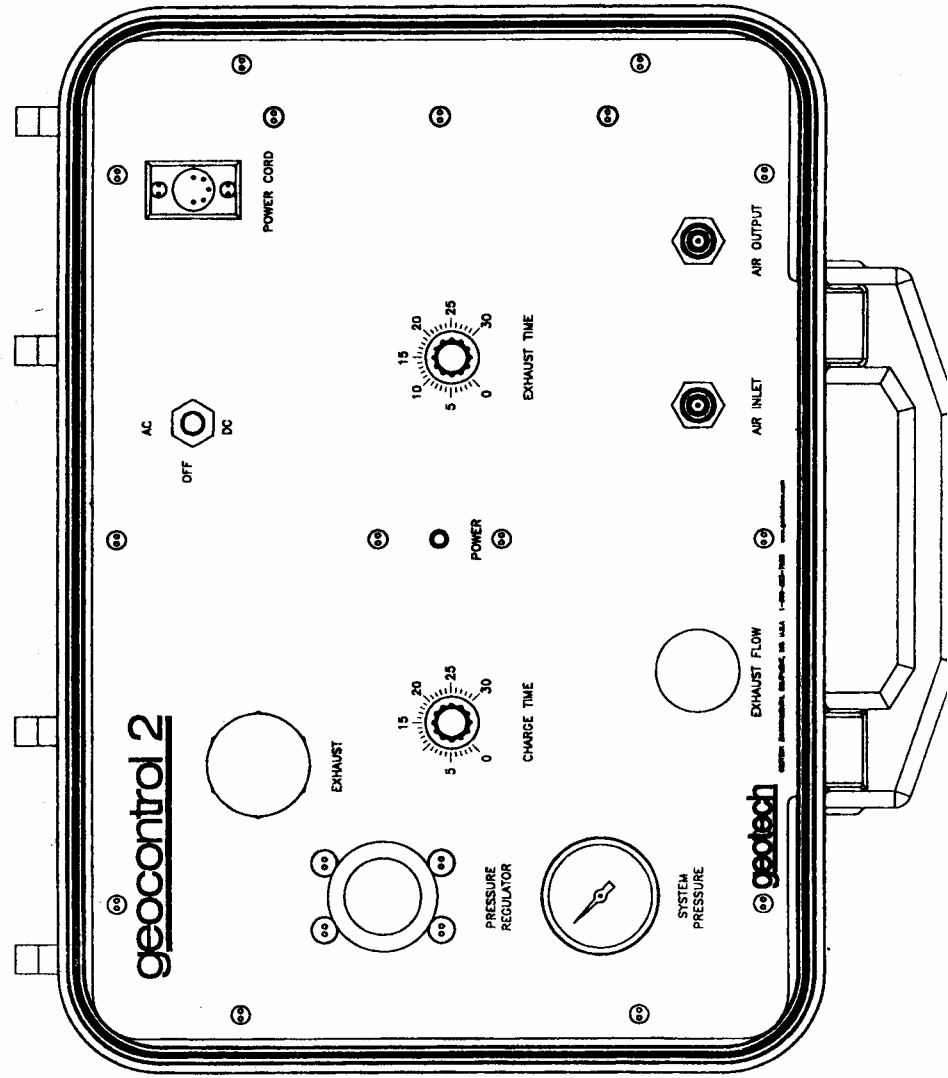

Chapter 8: Replacement Parts List

Part Number

11150172

57500008

51150038

51150039

11150170

Part Description

Assy, AC Power Cord

Assy, DC Power Cord

Assy, Air Inlet Hose

Assy, Air Exhaust Hose

Manual

Notes

Notes

The Warranty

For a period of one (1) year from date of first sale, product is warranted to be free from defects in materials and workmanship. Geotech agrees to repair or replace, at Geotech's option, the portion proving defective, or at our option to refund the purchase price thereof. Geotech will have no warranty obligation if the product is subjected to abnormal operating conditions, accident, abuse, misuse, unauthorized modification, alteration, repair, or replacement of wear parts. User assumes all other risk, if any, including the risk of injury, loss, or damage, direct or consequential, arising out of the use, misuse, or inability to use this product. User agrees to use, maintain and install product in accordance with recommendations and instructions. User is responsible for transportation charges connected to the repair or replacement of product under this warranty.

Equipment Return Policy

A Return Material Authorization number (RMA #) is required prior to return of any equipment to our facilities, please call 800 number for appropriate location. An RMA # will be issued upon receipt of your request to return equipment, which should include reasons for the return. Your return shipment to us must have this RMA # clearly marked on the outside of the package. Proof of date of purchase is required for processing of all warranty requests.

This policy applies to both equipment sales and repair orders.

FOR A RETURN MATERIAL AUTHORIZATION, PLEASE CALL OUR SERVICE DEPARTMENT AT 1-800-833-7958 OR 1-800-275-5325.

Model Number: _____

Serial Number: _____

Date: _____

Equipment Decontamination

Prior to return, all equipment must be thoroughly cleaned and decontaminated. Please make note on RMA form, the use of equipment, contaminants equipment was exposed to, and decontamination solutions/methods used.

Geotech reserves the right to refuse any equipment not properly decontaminated. Geotech may also choose to decontaminate equipment for a fee, which will be applied to the repair order invoice.

Geotech Environmental Equipment, Inc
8035 East 40th Avenue Denver, Colorado 80207
(303) 320-4764 • **(800) 833-7958** • FAX (303) 322-7242
email: sales@geotechenv.com website: www.geotechenv.com

Date: August 2007

Appendix D - Geotech Bladder Pumps

Date: August 2007

This page intentionally left blank.



Geotech Bladder Pumps

Installation and Operation Manual



Rev. 2 3/12/02 Part # 21150035

TABLE OF CONTENTS

Chapter 1: System Description	p. 03
Function and Theory	p. 03
System Components	p. 04
Bladder Cartridge Assembly	p. 04
Housing	p. 04
Intake screen	p. 04
Chapter 2: System Installation	p. 06
Bladder Pump	p. 06
Reverse Coil Method	p. 06
Chapter 3: System Operation	p. 08
Bladder Pump Operation	p. 08
Selecting an Air Source	p. 08
Determining PSI	p. 08
Flowrates	p. 09
Chapter 4: System Maintenance	p. 16
Bladder Pump	p. 16
Bladder Cartridge	p. 16
Chapter 5: System Troubleshooting	p. 18
Chapter 6: System Specifications	p. 20
Chapter 7: System Schematic	p. 22
Chapter 8: Replacement Parts List	p. 24
Warranty and Repair	p. 28

DOCUMENTATION CONVENTIONS

This manual uses the following conventions to present information:



WARNING

An exclamation point icon indicates a **WARNING** of a situation or condition that could lead to personal injury or death. You should not proceed until you read and thoroughly understand the **WARNING** message.



CAUTION

A raised hand icon indicates **CAUTION** information that relates to a situation or condition that could lead to equipment malfunction or damage. You should not proceed until you read and thoroughly understand the **CAUTION** message.



NOTE

A note icon indicates **NOTE** information. Notes provide additional or supplementary information about an activity or concept.

Chapter 1: System Description

Function and Theory

Geotech's pneumatic Bladder Pumps operate with a unique action, ideal for both, gentle low-flow sampling and high flow rate purging. Timed on/off cycles of compressed air alternately squeeze the flexible bladder to displace water out of the pump to the surface and exhaust allowing the pump to refill. Fluid enters the pump through the fluid inlet check valve at the bottom of the pump body, via hydrostatic pressure (automatically by submergence). The bladder then fills with fluid. Compressed air enters the space between the bladder and the interior of the pump wall housing. The intake check valve closes and the discharge check valve opens. The compressed air squeezes the bladder, pushing the fluid to the surface. The discharge check valve prevents back flow from the discharge tubing. Driven by the GEOCONTROLLER 2, this cycle automatically repeats.

Compressed air does not contact the sample! The bladder prevents contact between the pump drive air and the sample.

System Components

The GEOTECH Bladder Pump consists of three parts. The Bladder Cartridge Assembly, the Pump Housing, and the Intake Screen.

Bladder Cartridge Assembly

Geotech's bladder cartridge assembly is factory assembled and tested, and is designed to be field replaceable (see figure 1).

The cartridge assembly components consist of an upper and lower head constructed of virgin grade PTFE, (for bladder pump models GEO1.66PVC36 and GEO1.66PVC18 the upper and lower heads are constructed of NSF-grade PVC, extruded with no markings or lubricants). The internal flow tubes are constructed of electro polished 316 stainless steel, or NSF-grade PVC. The bladder material is constructed of inert virgin grade polymer resins, (proprietary resin grade PTFE – G303).

The bladder tube is assembled using a 316 stainless steel clamp, providing a true zero leak seal.

Housing

The bladder pump housing is constructed of electro polished 316 Stainless Steel. The housing components consist of threaded top and bottom caps, and the housing tube. For bladder pump models GEO1.66PVC36 and GEO1.66PVC18 the housing is constructed of NSF-grade PVC. Viton O-rings provide the high pressure seals between the end caps and the housing tube.

Intake screen

The intake filter screen is constructed of 316 Stainless Steel and is easily removable for field maintenance. For models Geo 1.66 PVC36 and Geo 1.66 PVC18, the intake screen is constructed of NSF-Grade PVC. The intake filter screen is intended to protect and extend the life of the bladder material (see warranty).



Figure 1 – SS Bladder Pump Assembly Figure 2 – PVC Bladder Pump Assembly

Chapter 2: System Installation

Bladder Pump

Geotech's Bladder Pumps are engineered for easy installation and use. Dedicated Bladder Pumps are shipped from GEOTECH with the tubing attached. Well identifications (supplied by customer) are located on tags connected to the tubing, and on the tubing bags.

Upon reaching the well head, connect the air line tubing to air line connection at the top of the Bladder Pump (see figure 3). The air line is smaller than the sample line. Next attach the sample line to the sample line connection at the top of pump (see figure 3).

The optional Bladder Pump Hanger is attached to the Quick Link on the safety cable and to the Pump Hanger. Carefully lower the Bladder Pump into the well using the reverse coil method to avoid kinking, until the well cap seats.

Reverse Coil Method (see figure 4)

When lowering the pump into the well it is important to reverse the natural bend of the coiled tubing so that the tubing will straighten out as it is lowered. As the pump and tubing are lowered down into the well, the direction of the bend should be reversed from the direction in which it is coiled up. If the tubing is allowed to uncoil naturally and the natural bend not interrupted, the tubing will continue its coil into the well. Using the reverse coil method will avoid hang-ups or difficulty in lowering the pump into the well, especially when the well is not completely vertical, or has come out of alignment for any reason.

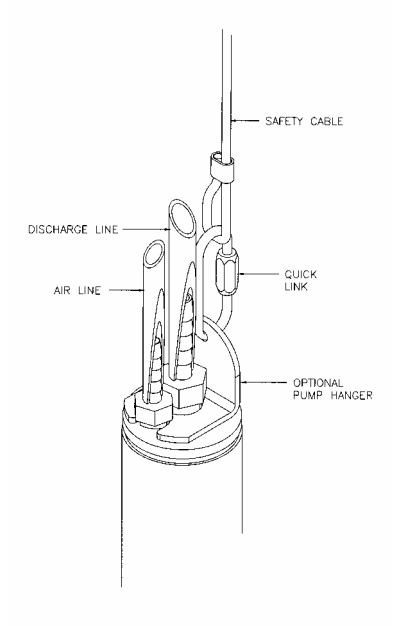

Figure 3

Figure 4 – Reverse Coil Method

Chapter 3: System Operation

Bladder Pump Operation

Fluid enters the pump through the fluid inlet check valve at the bottom of the pump body, and the bladder fills with fluid. Compressed air enters the space between the bladder and the interior of the pump wall housing, the inlet check valve closes and the discharge check valve opens. The compressed air squeezes the bladder pushing the fluid to the surface. The discharge check valve prevents backflow from the discharge tubing.

Selecting an Air Source

The following explanation is based on the Model GEO1.66SS36 with a .170 ID air supply tubing. To determine the required capacity of the air source used, calculate the air consumption as follows. With 100 ft. of air line tubing in or out of the well, the air consumption is 125 cubic inches per cycle, with 6 cycles per minute (average).

Example: For 100 ft. of tubing you will need 125 cu. in. x 6 per min. which equals 750 cu. in. / min. or 45,000 cu. in. / hr. For each additional 100 ft. add 59 cu. in. If you plan to use an air compressor we advise that you use one with a reserve tank to insure proper air supply to the pump. If you plan to use a Nitrogen Tank, see figure 9 for Nitrogen Tank Volume vs. Bladder Pump consumption.

Determining PSI

Determine the air pressure needed to operate the Bladder Pump based on the length of the air supply line to the pump (well depth). Use the simplified formula of (1/2 PSI per foot) + 10 PSI for friction.

Example: For a pump 100 ft. away from the air source, uses 100 ft. divided by 2 then add 10. This equals 60 PSI ($100' / 2 + 10 = 60$ PSI).

The additional 10 PSI is to account for the pump itself and friction loss along the air line tubing. When the length of the air line to the Bladder Pump is 50 ft. or less, the additional 10 PSI need not be added.

To determine minimum operating pressures for the specific Bladder Pump model you are using, consult pumps specifications. Typically the minimum operating pressure will be 5 PSI above static head.

Example: Bladder Pump depth is 50 ft. $50 / 2 = 25 + 5 = 30$ PSI.

The formulas stated above are not absolute, and are meant to provide baseline information.

Flowrates

Flow rates are based on Geotech's models GEO1.66ss36 Stainless Steel Bladder Pump, and GEO1.66PVC36 PVC Bladder Pumps PERFORMANCE CURVE (see figures 5, 6, 7, & 8).

For determining the number of cycles it will take to receive sample fluid at the well head, see figure 9 CYCLES vs. DEPTH.

If using a nitrogen tank as an air source, see figure 10 NITROGEN TANK VOLUME vs. BLADDER PUMP CONSUMPTION.

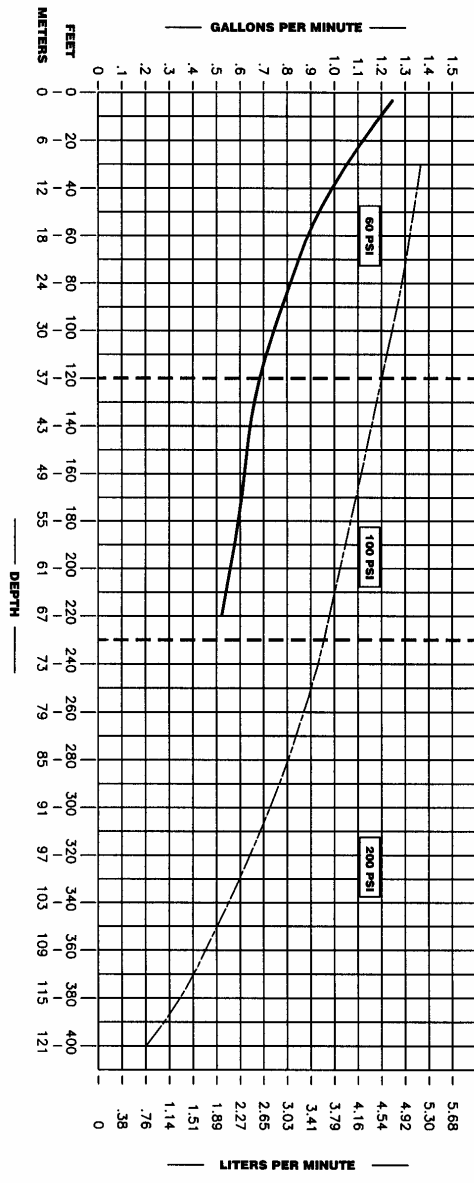

NOBLE CORP. PASSAGE
 TUBE CONNECTIONS
 1.7" ID AIR INLET TUBE AND .25" ID PRODUCT
 DISCHARGE TUBE

PERFORMANCE CURVE

SUBMERGENCE

30 FT. 9.15 M

2 FT. 60.0 CM

* FLOW RATES WILL VARY WITH ON-SITE CONDITIONS

Figure 5 – Performance Curve
 10

MODEL: CE01 685326
 TEST CONDUCTED AT INLET PRESSURES STATED WITH
 .25" ID AIR INLET TUBE AND .25" ID PRODUCT
 DISCHARGE TUBE

SUBMERGENCE
 - - - - - 30 FT. 9.15 M
 _____ 2 FT. 60.0 CM

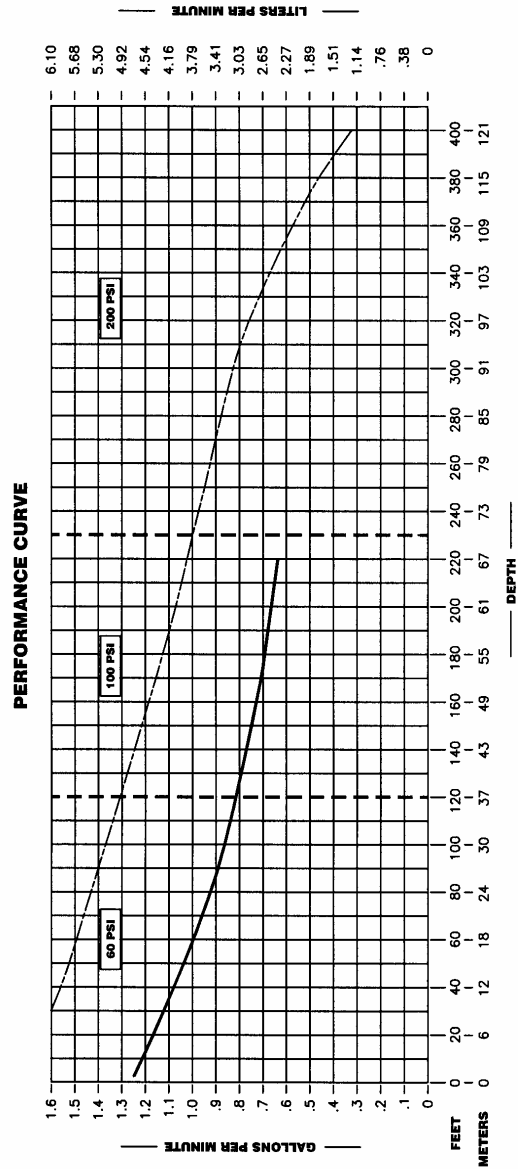

* FLOW RATES WILL VARY WITH ON-SITE CONDITIONS

Figure 6 – Performance Curve
 11

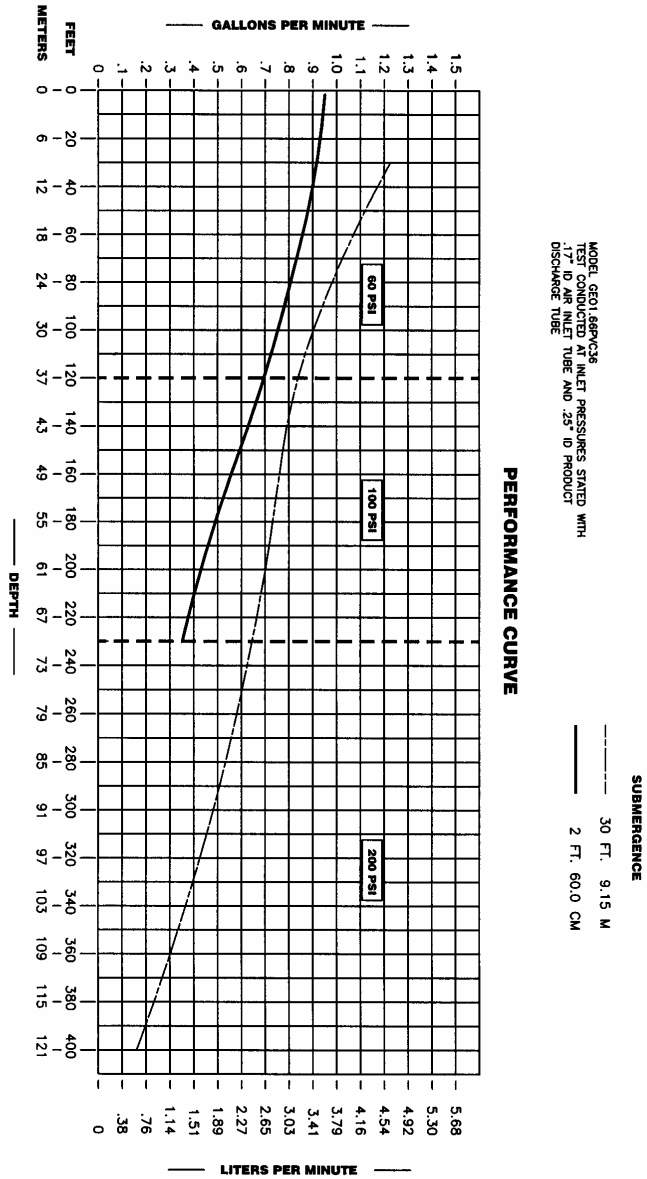
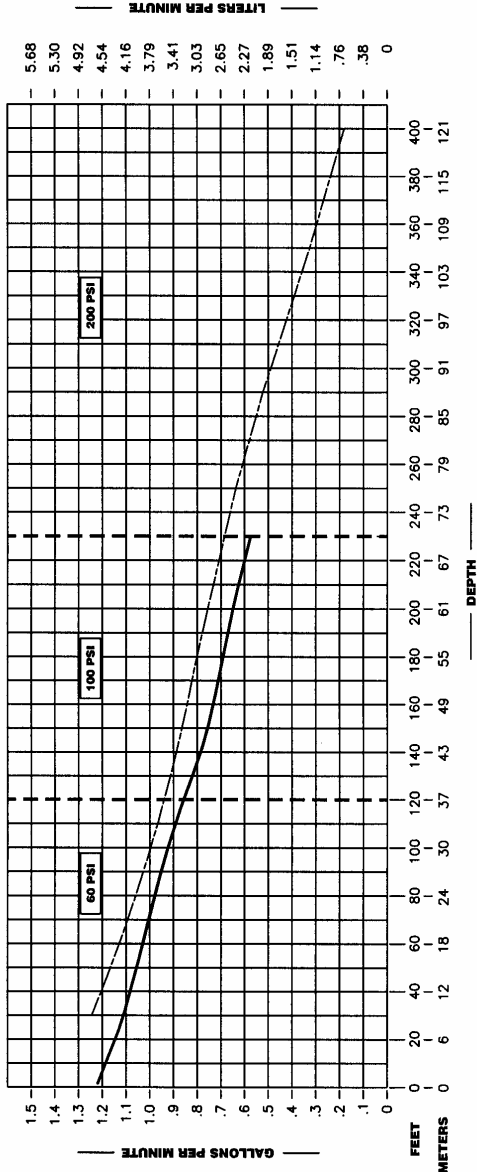

Figure 7 – Performance Curve

MODEL GE01.66PAC36
 TEST CONDUCTED AT INLET PRESSURES STATED WITH
 .25" ID AIR INLET TUBE AND .25" ID PRODUCT
 DISCHARGE TUBE

SUBMERGENCE
 - - - - - 30 FT. 9.15 M
 _____ 2 FT. 60.0 CM

PERFORMANCE CURVE



* FLOW RATES WILL VARY WITH ON-SITE CONDITIONS

Figure 8 – Performance Curve

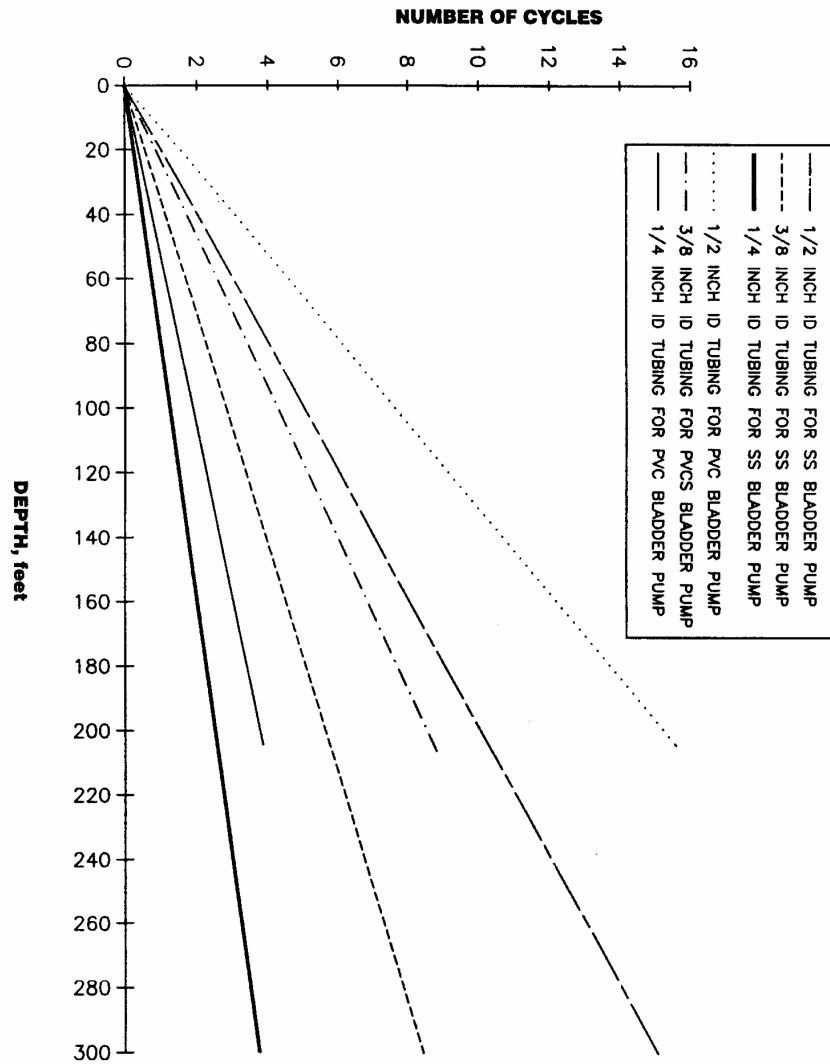

Figure 9 – Cycles vs. Depth

NITROGEN TANK VOLUME VS BLADDER PUMP CONSUMPTION

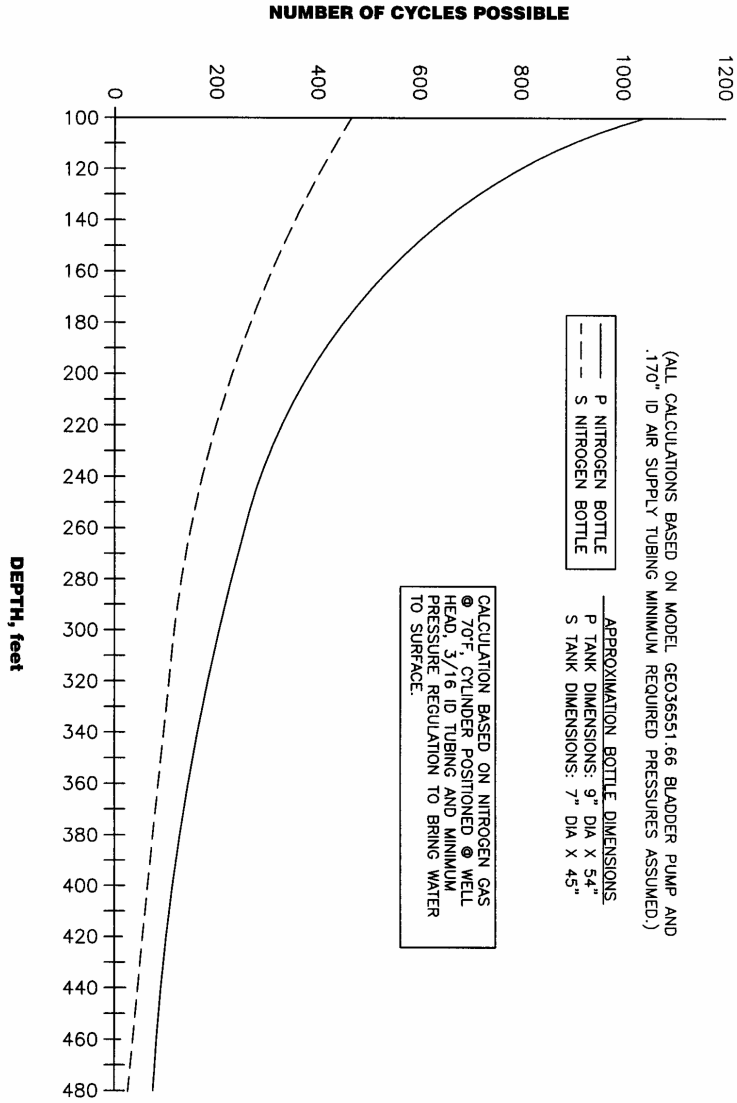

Figure 10 – Nitrogen Tank vs. Bladder Pump Consumption

Date: February 2007

This page intentionally left blank.

Chapter 4: System Maintenance

Bladder Pump

As with any pump, scheduled or periodic maintenance should be performed, according to your sampling program and specific site conditions. Generally, the more turbid or sandy your water, the more often you should maintain and clean your pumps. (See System components, Bladder Cartridge Assembly). Disassemble Bladder Pump per instructions, decontaminate or replace as needed, then reassemble. Inspect all check balls for wear and replace as necessary. Inspect all O-rings for splits or cracks and replace as necessary.

Bladder Cartridge

When installing a new bladder cartridge, or performing maintenance on an existing cartridge use the following instructions:

- Pull pump from the well, it is not necessary to remove the air and sample lines from the pump.
- (Models w/screens) Using an Allen head tool, remove the shoulder bolts from the intake screen cap (see figure 1).
- Using the Spanner tool, while holding pump body, with your hand or with a strap wrench, use a spanner tool to turn lower head in a counter clockwise direction and remove. Pump head will be very snug due to the high pressure O-ring seal. Once the seal is broken, the lower head will turn very easily (see figure 12).
- The internal bladder cartridge can now be removed for maintenance or replacement. Gently tap the tube housing on a firm wood like surface until the cartridge drops from the upper head seal. Reach into the tube with one or two fingers and pull the cartridge free.
- Before replacing lower pump head, always check o-rings for rips or cracks and replace as necessary.
- For models without intake screens, use the Spanner tool provided for lower head removal (see figure 12).

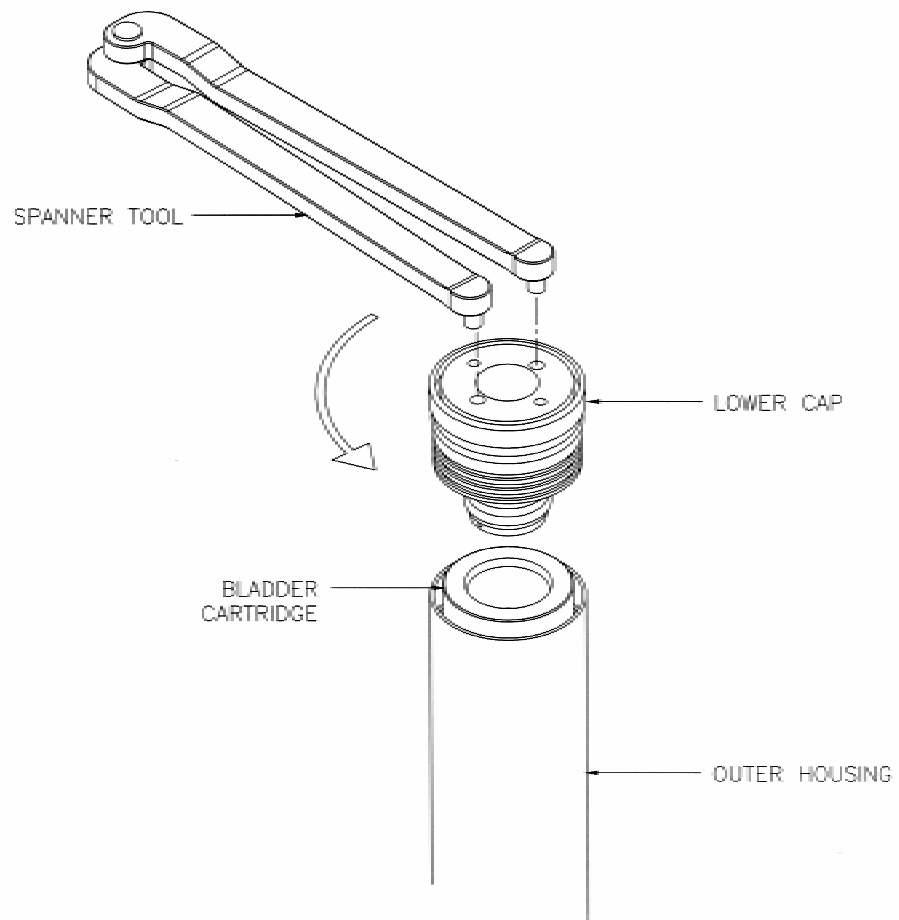

Figure 11
17

Chapter 5: System Troubleshooting

Bladder Pump: Troubleshooting

Problem:

Solutions:

Air is cycling thru controller, but will not pump...

- 1) Charge and exhaust times are not set correctly.
Check and adjust charge and exhaust cycle times (i.e. if charge time is too long or if exhaust and charge time is too short).
- 2) Possible compromise in air line tubing.
Check air line pump for leaks. If needed, repair using compression union or replace tubing.
- 3) Check pump intake screen for blockage and clean as needed.

Controller is cycling but the pump stops producing water...

- 1) Check drawdown level of water in the well.
Ensure the pump is fully submerged and off of the bottom of the well.
- 2) Check psi at the regulator and adjust as necessary (see page 8).
- 3) Check for kinks in the discharge line.
- 4) Check pump intake screen for obstructions.
- 5) Charge time is too long or exhaust time is too short; causes pressure build up in pump, causing the pump not to fill.
- 6) Check power source, assure a strong reliable power supply. If using an old or weak battery, the control valves may not operate properly.

System Troubleshooting cont...

Getting air bubbles in sample line...

- 1) Over charging pump.
Reduce charge cycle time so that charge cycle ends as fluid discharge trails off.
Inspect pump for compromised bladder or o-rings.
- 2) Pump is being over pressurized (PVC pump).
Reduce psi to what is necessary to overcome pumping head (see page 8 for determining psi).
- 3) Check discharge line for holes or kinks.
Repair using compression union or replace tubing.

Discharge line drains back into pump...

- 1) Remove Hosebarb on pump discharge outlet.
Check the check ball seat for debris. Clean and re-install.

Chapter 6: System Specifications

	GEO1.66SS36	GEO1.66SS18	GEO1.66PVC36
Pump Housing	SS, 316	SS, 316	PVC
Pump Ends	Virgin PTFE	Virgin PTFE	PVC
Bladder Matl.	Virgin PTFE Proprietary resin Grade (G303)	Virgin PTFE Proprietary resin grade (G303)	Virgin PTFE (Proprietary resin grade G303)
O.D.:	1.66"/4.2cm	1.66"/4.2cm	1.66"/4.2cm
Length: w/o screen	36"/91.4cm	18"/45.7cm	36"/91.4cm
Length: w/screen	38"/96.5cm	20"/51cm	—
Weight	5lb/1.9Kg.	2.5lb/0.93Kg	3.6lb/1.3Kg
Volume/Cycle	21.1oz./625ml	10.5oz./313ml	13.8oz.408ml
Max. Flowrate*	1.25gpm/4.7lpm	.65gpm/2.4lpm	.97gpm/3.7lpm
Min. Well I.D.	2"/50mm	2"/50mm	2"/50mm
Operating Press.	10-450psi/.7-31 bar	10-450psi/.7-31bar	10-110psi/.7-7.5 bar
Min. Operating Range	5psi/.34bar above static head	5psi/.34bar above static head	5psi/.34bar above static head
Maximum Depth **	1000'/305m	1000'/305m	250'/76.2M

* Flow rate determined @ 2ft/60cm submergence

** With the use of a drop tube, maximum depth is increased

System Specifications

	GEO1.66PVC18	GEO850.SS24	GEO675.SS18
Pump Housing	PVC	SS, 316	SS, 316
Pump Ends	PVC	Virgin PTFE	Electropolished SS 316
Bladder Matl.	Virgin PTFE (Proprietary resin grade G303)	Virgin PTFE (Proprietary resin grade G303)	Virgin PTFE (Proprietary resin grade G303)
O.D.:	1.66"/4.2cm	.850"/2.2cm	.675"/1.7cm
Length: w/o screen	18"/45.7cm	24"/61cm	N/A
Length: w/screen	22"/55.9cm	25"/63.5cm	18"
Weight	1.8lb/.67Kg	1.6/.60Kg	.83lb/.38Kg
Volume/Cycle	6.9oz./204ml	2.1oz./59.6ml	1.35oz./38.4ml
Max. Flowrate*	.53gpm/2.0lpm	.10gpm/.36lpm	.05gpm/.19lpm
Min. Well I.D.	2"/25mm	1.00"/25mm	.75"/19mm
Operating Press.	10-110psi/.7-7.5bar	10-110psi/.7-7.5bar	10-110psi/.7-7.5bar
Min. Operating Range	5psi/.34bar above static head	5psi/.34bar above static head	5psi/.34bar above static head
Maximum Depth **	250'/76.2m	250'/76.2m	250'/76.2m

Chapter 7: System Schematic

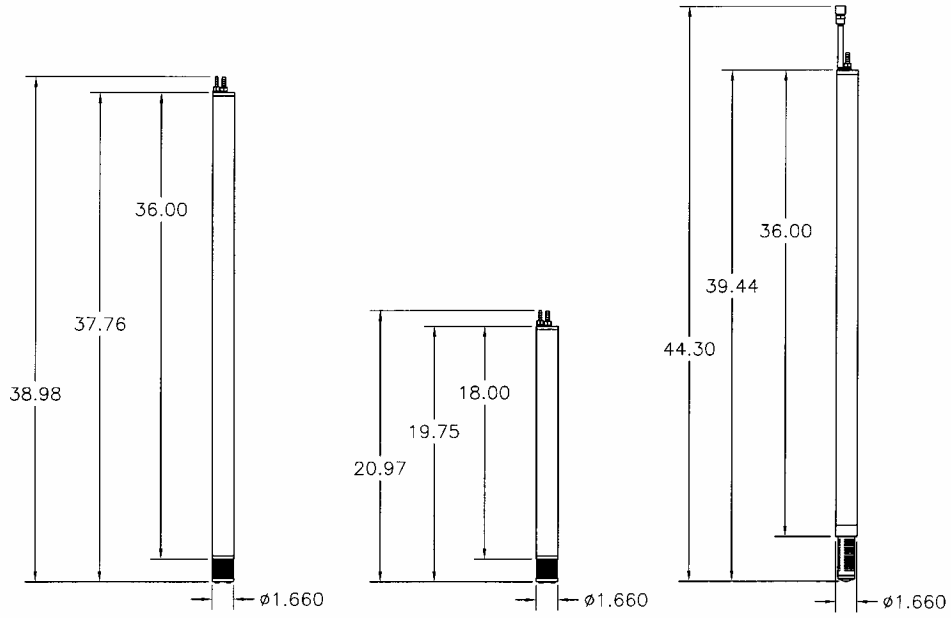

GEO1.66SS36

GEO1.66SS18

GEO1.66PVC36

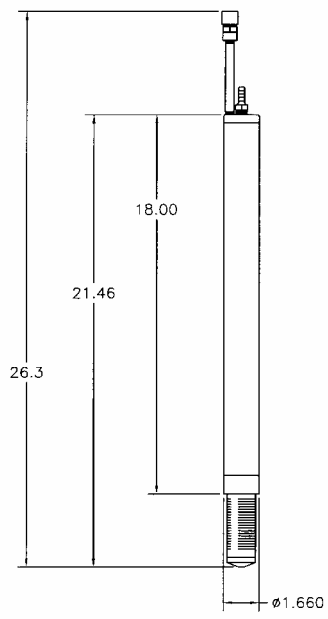

GEO1.66PVC18

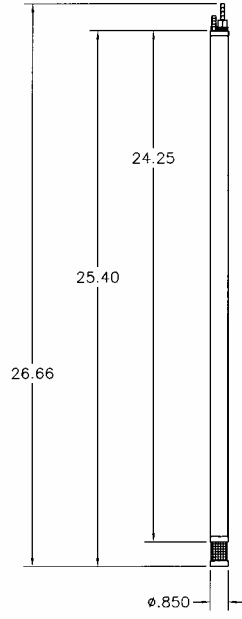

GEO850.SS24

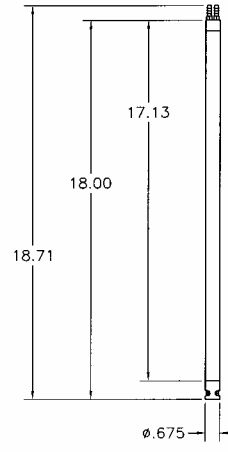

GEO675.SS18

Chapter 8: Replacement Parts List

Model GEO1.66SS36

QTY/ASSY	DESCRIPTION	PART #
1	Bladder Cartridge	51150100
1	Cap, Upper	11150104
1	Cap, Lower	11150107
1	Screen, Intake	11150109
2	Bolts, Shoulder	17200241
1	Hose barb, Sample out	11150106
1	Hose barb, Air in	17200241
1	Check ball, Upper	17500081
1	Check ball, Lower	17500082
1	O-Ring Viton cap/upper lower	17500104
2	O-Ring Viton cap/upper head interface	17500103
2	O-Ring Viton cap/lower head interface	17500106

MODEL GEO1.66SS18

QTY/ASSY	DESCRIPTION	PART #
1	Bladder Cartridge	51150106
1	Cap, Upper	11150104
1	Cap, Lower	11150107
1	Screen, Intake	11150109
2	Bolts, Shoulder	17200241
1	Hose barb, Sample out	11150106
1	Hose barb, Air in	21150019
1	Check ball Upper	17500081
1	Check ball Lower	17500082
1	O-Ring Viton cap/upper lower	17500104
2	O-Ring Viton cap/upper head interface	17500103
2	O-Ring Viton cap/lower head interface	17500106

Model GEO1.66PVC36

QTY/ASSY	DESCRIPTION	PART #
1	Bladder Cartridge	51150107
1	Cap, Upper	11150128
1	Cap, Lower	11150129
1	Screen, Intake	11150109
2	Cap Screen Intake	11150131
1	Hose barb, Sample out	11150134
1	Hose barb, Air in	17200248
1	Check ball, PVC Upper/lower	17500115
1	O-Ring, Viton cap/upper/lower	17500120
1	O-Ring Viton cap/head interface	17500119

MODEL GEO1.66PVC18

QTY/ASSY	DESCRIPTION	PART #
1	Bladder Cartridge	51150108
1	Cap, Upper	11150128
1	Cap, Lower	11150129
1	Screen, Intake	11150130
2	Cap, screen intake	11150131
1	Hose barb, Sample out	11150134
1	Hose barb, Air in	17200248
1	Check, PVC Upper/lower	17500115
1	O-Ring Viton cap/upper lower	17500120
2	O-Ring Viton cap/head interface	17500119

Model GEO850.SS24

QTY/ASSY	DESCRIPTION	PART #
1	Bladder Cartridge	51150103
1	Cap, Upper	11150111
1	Cap, Lower	11150112
1	Screen, Intake	11150119
2	Screw 4-40 x 1	17200246
1	Hose barb, Sample out	11150118
1	Hose barb, Air in	17200245
1	Check ball	17500079
1	O-Ring, Viton cap/upper/lower	17500112
2	O-Ring Viton cap/upper head interface	17500119
2	O-Ring Viton cap/lower head interface	17500111

MODEL GEO.675SS18

QTY/ASSY	DESCRIPTION	PART #
1	Bladder Cartridge	51150116
1	Cap, Upper	21150030
1	Cap, Lower	21150031
2	Hose barb, air sample	17200245
1	Check ball, upper	ppm130001
1	Check ball, lower	17500079
1	Disc Teflon	21150033
1	Snapping	11150182
1	O-Ring, Bladder Cap, Upper	11150183
1	O-Ring, Bladder Cap, Lower	17500183
2	O-Ring, cap housing	11150184

Notes

The Warranty

For a period of one (1) year from date of first sale, product is warranted to be free from defects in materials and workmanship. Geotech agrees to repair or replace, at Geotech's option, the portion proving defective, or at our option to refund the purchase price thereof. Geotech will have no warranty obligation if the product is subjected to abuse, misuse, or inability to use this product. User assumes all other risk, if any, including the risk of injury, loss, or damage, direct or consequential, arising out of the use, misuse, or inability to use this product. User agrees to use, maintain and install product in accordance with recommendations and instructions. User is responsible for transportation charges connected to the repair or replacement of product under this warranty.

Equipment Return Policy

A Return Material Authorization number (RMA #) is required prior to return of any equipment to our facilities, please call 800 number for appropriate location. An RMA # will be issued upon receipt of your request to return equipment, which should include reasons for the return. Your return shipment to us must have this RMA # clearly marked on the outside of the package. Proof of date of purchase is required for processing of all warranty requests.

This policy applies to both equipment sales and repair orders.

FOR A RETURN MATERIAL AUTHORIZATION, PLEASE CALL OUR
SERVICE DEPARTMENT AT 1-800-833-7958 OR 1-800-275-5325.

Model Number: _____
Serial Number: _____
Date: _____

Equipment Decontamination

Prior to return, all equipment must be thoroughly cleaned and decontaminated. Please make note on RMA form, the use of equipment, contaminants equipment was exposed to, and decontamination solutions/methods used.

Geotech reserves the right to refuse any equipment not properly decontaminated. Geotech may also choose to decontaminate equipment for a fee, which will be applied to the repair order invoice.

Geotech Environmental Equipment, Inc
8035 East 40th Avenue Denver, Colorado 80207
(303) 320-4764 • **(800) 833-7958** • FAX (303) 322-7242
email: sales@geotechenv.com website: www.geotechenv.com

Date: August 2007

This page intentionally left blank.

Date: August 2007

Appendix E - Standard Operating Procedures – Recordkeeping and Sample Handling

RECORD KEEPING, SAMPLE LABELING, AND CHAIN-OF-CUSTODY PROCEDURES

1.0 PURPOSE

The purpose of this standard operating procedure (SOP) is to establish standard protocols for all U.S. Navy PACDIV IRP field personnel for use in maintaining field and sampling activity records, writing sample logs, labeling samples, ensuring that proper sample custody procedures are utilized, and completing chain-of-custody/analytical request forms.

2.0 SCOPE

This procedure shall apply to all sample collection conducted during U.S. NAVY PACDIV IRP activities.

This procedure shall serve as management-approved professional guidance for the U.S. Navy PACDIV IRP. It is not intended to obviate the need for professional judgment that may arise in unforeseen circumstances. Deviations from this procedure in the planning or the execution of activities must be approved by the CTO/DO Manager and Technical Director/QA Program Manager.

3.0 DEFINITIONS

3.1 LOGBOOK

A bound field notebook with consecutively numbered, water-repellent pages that is clearly identified with the name of the affected activity, the person assigned responsibility for maintenance of the logbook, and the beginning and ending dates of the entries.

3.2 CHAIN-OF-CUSTODY (COC)

Documentation of the process of custody control. Custody control includes possession of a sample from the time of its collection in the field to its receipt by the analytical laboratory, and through analysis and storage prior to disposal.

3.3 CTO/DO LABORATORY COORDINATOR

The person for each CTO/DO who is the main point of contact with the Laboratory Project Manager. This may or may not be the CTO/DO QC Coordinator.

4.0 RESPONSIBILITIES

U.S. NAVY PACDIV IRP field personnel are responsible for following these procedures during conduct of sampling activities. U.S. NAVY PACDIV IRP CTO/DO field personnel are responsible for recording pertinent data into the logbook to satisfy project requirements and for attesting to the accuracy of the entries by dated signature.

The Field Program Manager is responsible for ensuring that all field personnel follow these procedures. The CTO/DO Laboratory Coordinator is responsible for verifying that the COC/Analytical Request Forms have been completed properly and match the sampling and analytical plan. The CTO/DO Manager or CTO/DO Laboratory Coordinator is responsible for notifying the laboratory, data managers, and data validators in writing if analytical request changes are required as a corrective action. These small changes are different from change orders, which involve changes to the scope of the subcontract with the laboratory and must be made in accordance with a respective contract (e.g., CLEAN, RAC.)

The CTO/DO Manager is responsible for determining which team members shall record information in the field logbook and for checking sample logbooks and chain-of-custody forms to ensure compliance with these procedures.

The Laboratory Project Manager or Sample Control Department Manager is responsible for reporting any sample documentation or chain-of-custody problems to the CTO/DO Manager or CTO/DO Laboratory Coordinator within 24 hours of sample receipt.

The Technical Director/QA Program Manager is responsible for evaluating project compliance with these procedures. The Technical Director/QA Program Manager, or designee, is responsible for reviewing logbook entries, sample labeling, and chain-of-custody records to ensure that all are adequate to meet project requirements.

5.0 PROCEDURES

Standards for documenting field activities, labeling the samples, documenting sample custody, and completing chain-of-custody/analytical request forms are provided in this procedure. The standards presented in this section shall be followed to ensure that samples collected are maintained for their intended purpose and that the conditions encountered during field activities are documented.

5.1 RECORD KEEPING

The field logbook serves as the primary record of field activities. Entries shall be made chronologically and in sufficient detail to allow the writer or a knowledgeable reviewer to reconstruct each day's events. Field logs such as soil boring logs and ground-water sampling logs will also be used. These procedures are described in SOP III-D, *Logbooks*.

5.2 SAMPLE LABELING

A sample label with adhesive backing shall be affixed to each individual sample container. Clear tape shall be placed over each label (preferably prior to sampling) to prevent the labels from tearing off, falling off, being smeared, and to prevent loss of information on the label. The following information shall be recorded with a waterproof marker on each label:

- Project name or number (optional)
- EPA sample number
- Date and time of collection
- Sampler's initials
- Matrix (optional)
- Sample preservatives (if applicable)
- Analysis to be performed on sample (typically for water samples only)*. This shall be identified by the method number or name identified in the subcontract with the laboratory. For water samples, a separate container is typically used

for each separate test method, whereas with soil samples, all analyses are typically performed on the soil obtained from one sample container. In order to avoid lengthy lists on each container and confusion, soil sample containers typically don't list every analysis to be performed.

These labels may be obtained from the analytical laboratory or printed from a computer file onto adhesive labels.

5.3 CUSTODY PROCEDURES

For samples intended for chemical analysis, sample custody procedures shall be followed through collection, transfer, analysis, and disposal to ensure that the integrity of the samples is maintained. Custody of samples shall be maintained in accordance with EPA chain-of-custody guidelines as prescribed in EPA *NEIC Policies and Procedures*, National Enforcement Investigations Center, Denver, Colorado, revised May 1986; EPA *RCRA Ground Water Monitoring Technical Enforcement Guidance Document (TEGD)*, *Guidance for Conducting Remedial Investigations and Feasibility Studies Under CERCLA* (EPA OSWER Directive 9355 3-01), Appendix 2 of the *Technical Guidance Manual for Solid Waste Water Quality Assessment Test (SWAT) Proposals and Reports*, and *Test Methods for Evaluating Solid Waste* (EPA SW-846). A description of sample custody procedures is provided below.

5.3.1 Sample Collection Custody Procedures

According to EPA *NEIC Policies and Procedures*, a sample is considered to be in custody if:

- It is in one's actual physical possession or view
- It is in one's physical possession and has not been tampered with (i.e., it is under lock or official seal)
- It is retained in a secured area with restricted access
- It is placed in a container and secured with an official seal such that the sample cannot be reached without breaking the seal

Custody seals shall be placed on sample containers immediately after sample collection and on shipping coolers if the cooler is to be removed from the sampler's custody. Custody seals will be placed in such a manner that they must be broken to open the containers or coolers. The custody seals shall be labeled with the following information:

- Sampler's name or initials
- Date and time that the sample/cooler was sealed.

These seals are designed to enable detection of sample tampering. An example of a custody seal is shown in Attachment III-E-1.

Field personnel shall also log individual samples onto carbon copy chain-of-custody forms when a sample is collected. These forms may also serve as the request for analyses. Procedures for completing these forms are discussed in Section 5.4 indicating sample EPA number, matrix, date and time of collection, number of containers, analytical methods to be performed on the sample, and preservatives added (if any). The samplers will also sign the COC form signifying that they were the personnel who collected the samples. The COC form shall accompany the samples from the field to the laboratory. When a cooler is ready for shipment to the analytical laboratory, the person delivering the samples for transport will sign and indicate the date and time on the accompanying COC form. One copy of the COC form will be retained by the sampler and the remaining copies of the COC form shall be placed inside a self-sealing bag and taped to the inside of the cooler. Each cooler must be associated with a unique COC form. Whenever a transfer of custody takes place, both parties shall sign and date the accompanying carbon copy COC forms, and the individual relinquishing the samples shall retain a copy of each form. One exception is when the samples are shipped; the delivery service personnel will not sign or receive a copy because they do not open the coolers. The laboratory shall attach copies of the completed COC forms to the reports containing the results of the analytical tests. An example COC form is provided in Attachment 2.

5.3.2 Laboratory Custody Procedures

The following are custody procedures to be followed by an independent laboratory receiving samples for chemical analysis; the procedures in their laboratory Quality Assurance Plan (LQAP) must follow these same procedures. A designated sample

custodian shall take custody of all samples upon their arrival at the analytical laboratory. The custodian shall inspect all sample labels and COC forms to ensure that the information is consistent, and that each is properly completed. The custodian will also measure the temperature of the samples in the coolers upon arrival. The custodian shall also note the condition of the samples including:

- if the samples show signs of damage or tampering
- if the containers are broken or leaking
- if headspace is present in sample vials
- proper preservation of samples (made by pH measurement, except VOCs and purgeable TPH). The pH of these samples will be checked by the laboratory analyst after the sample aliquot has been removed from the vial for analysis.
- if any sample holding times have been exceeded

All of the above information shall be documented on a sample receipt sheet by the custodian.

Any discrepancy or improper preservation shall be noted by the laboratory as an out-of-control event and shall be documented on an out-of-control form with corrective action taken. The out-of-control form shall be signed and dated by the sample control custodian and any other persons responsible for corrective action. An example of an out-of-control form is included as Attachment III-E-4.

The custodian shall then assign a unique laboratory number to each sample and distribute the samples to secured storage areas maintained at 4°C. The unique laboratory number for each sample, the EPA sample number, the client name, date and time received, analysis due date, and storage shall also be manually logged onto a sample receipt record and later entered into the laboratory's computerized data management system. The custodian shall also sign the shipping bill and maintain a copy.

Laboratory personnel shall be responsible for the care and custody of samples from the time of their receipt at the laboratory through their exhaustion or disposal. Samples

should be logged in and out on internal laboratory COC forms each time they are removed from storage for extraction or analysis.

5.4 COMPLETING CHAIN-OF-CUSTODY/ANALYTICAL REQUEST FORMS

COC form/analytical request completion procedures are crucial in properly transferring the custody and responsibility of samples from field personnel to the laboratory. This form also is important for accurately and concisely requesting analyses for each sample; it is essentially a release order from the analysis subcontract.

Attachment III-E-2 is an example of a generic COC/analytical request form that may be used by field personnel. Multiple copies may be tailored to each project so that much of the information described below need not be handwritten each time. Attachment III-E-3 is an example of a completed site-specific COC/analytical request form, with box numbers identified and discussed in text below.

Box 1 Project Manager: This name shall be the name that will appear on the report. Do not write the name of the Project Coordinator or point of contact for the project instead of the CTO/DO manager.

Project Name: Write it as it is to appear on the report.

Project Number: Write it as it is to appear on the report. It shall include the project number, task number, and general ledger section code. The laboratory subcontract number should also be included.

Box 2 Bill to: List the name and address of the person/company to bill only if it is not in the subcontract with the laboratory.

Box 3 Sample Disposal Instructions: These instructions will be stated in the Basic Ordering Agreement (BOA) or each CTO/DO statement of work with each laboratory.

Shipment Method: State the method of shipment, e.g., hand carry; air courier via FED EX, AIR BORNE or DHL.

Comment: This area shall be used by the field team to communicate

observations, potential hazards, or limitations that may have occurred in the field or additional information regarding analysis. For example: a specific metals list, explanation of Mod 8015, Mod 8015 + Kerosene, samples expected to contain high analyte concentrations.

Box 4 Cooler Number: This will be written somewhere on the inside or outside of the cooler and shall be included on the COC. Some laboratories attach this number to the trip blank identification which helps track VOA samples. If a number is not on the cooler, field personnel shall assign a number, write it on the cooler, and write it on the COC.

QC Level: Enter the reporting/QC requirements, e.g., PACDIV QC Level C, D, or E.

Turn around time (TAT): TAT for contract work will be determined by a sample delivery group (SDG) which may be formed over a 14-day period, not to exceed 20 samples. Standard turnaround time once the SDG has been completed is 35 calendar days from receipt of the last sample in the SDG. Entering NORMAL or STANDARD in this field will be acceptable. If quicker TAT is required, it shall be in the subcontract with the laboratory and reiterated on each COC to remind the laboratory.

Box 5 Type of containers: The type of container used, e.g., 1 liter glass amber, for a given parameter in that column.

Preservatives: Field personnel must indicate on the COC the correct preservative used for the analysis requested. Indicate the pH of the sample (if tested) in case there are buffering conditions found in the sample matrix.

Box 6 EPA number: Five-character alpha-numeric identifier to be used by the laboratory to identify samples. The use of this identifier is important since the labs are restricted to the number of characters they are able to use. See SOP I-A-9, *Sample Naming*.

Description (sample identification): This name will be determined by the location and description of the sample, as described in SOP I-A-9, *Sample*

Naming. This sample identification should not be submitted to the laboratory, but should be left blank. If a computer COC version is used, the sample identification can be input but printed with this block black. A cross-referenced list of EPA number and sample identification must be maintained separately.

Date Collected: Collection date must be recorded in order to track the holding time of the sample. Note: For trip blanks, record the date it was placed in company with samples.

Time Collected: When collecting samples, record the time the sample is first collected. Use of the 24-hour military clock will avoid a.m. or p.m. designations; e.g., 1815 instead of 6:15 p.m. Record local time; the laboratory is responsible for calculating holding times to local time (Guam is 17 hours ahead of California during daylight savings time).

Lab Identification: This is for laboratory use only.

Box 7 **Matrix and QC:** Identify the matrix: e.g., water, soil, air, tissue, fresh water sediment, marine sediment, or product. If a sample is expected to contain high analyte concentrations, e.g., a tank bottom sludge or distinct product layer, notify the laboratory in the comment section. Mark an "X" for the sample(s) that have extra volume for laboratory QC matrix spike/matrix spike duplicate (MS/MSD) purposes. The sample provided for MS/MSD purposes is usually a field duplicate.

Box 8 **Analytical Parameters:** Enter the parameter by descriptor and the method number desired. For example, Attachment 3 shows OLM01.8V as a column heading; this includes the CLP revision number and an indicator of the analytical category. When requesting metals that are modifications of the standard lists, define the list in the comment section. This would not be necessary when requesting standard list metals such as priority pollutant metals (PPM), target compound list from ILM03.0, and Title 22 metals which are groups of metals commonly requested and should not cause any confusion as to what metals are being analyzed. Whenever possible, list the parameters

as they appear in the laboratory subcontract to maintain consistency and avoid confusion.

In the boxes below the analytical parameter, indicate the number of containers collected for each parameter by marking an "X". If more than one container is used for a sample, write a number in the desired box to indicate a request for analysis and to indicate the number of containers sent for that analysis.

Box 9 **Sampler's Signature:** The person who collected samples must sign here.

Relinquished By: This space shall contain the signature of the person who turned over the custody of the samples to a second party other than an express mail carrier such as FEDEX, DHL or Air Borne Express.

Received By: Typically, this is signed by a representative of the receiving laboratory. Or, this signature could be from a field crew member who delivered the samples in person from the field to the laboratory. A courier such as Federal Express or DHL does not sign this because they do not open the coolers. It must also be used by the prime contracting laboratory when samples are to be sent to a subcontractor.

Relinquished By: In the case of subcontracting, the primary laboratory will sign the Relinquished By space and fill out an additional COC to accompany the samples being subcontracted.

Received By (Laboratory): This space is for the final destination, e.g., at a subcontracted laboratory.

Box 10 **Lab Number and Questions:** This box is to be filled in by the laboratory only.

Box 11 **Control Number:** This number is the "COC" followed by the first EPA number in that cooler, or contained on that COC. This control number must be unique, i.e., never used twice. Record the date the COC is completed. It should be the same date the samples are collected.

Box 12 **Total No. of Containers/row:** Sum the number of containers in that row.

Box 13 **Total No. of Containers/column:** Sum the number of containers in that column. Because COC forms contain different formats based upon who produced the form, not all of the information listed in items 1 to 13 may be recorded. However, as much of this information as possible shall be included.

COC forms tailored to each CTO/DO can be drafted and printed onto multi-ply forms. This eliminates the need to rewrite the analytical methods column headers each time. It also eliminates the need to write the project manager, name, and number; QC Level; TAT; and the same general comments each time.

Complete one COC form per cooler. Whenever possible, place all VOA vials into one cooler in order to reduce the number of trip blanks. Complete all sections and be sure to sign and date the COC form. One copy of the COC form must remain with the field personnel.

6.0 RECORDS

The COC/analytical request form shall be faxed approximately daily to the CTO/DO Laboratory Coordinator for verification of accuracy. Following the completion of sampling activities, the sample logbook and COC forms will be transmitted to the CTO/DO Manager for storage in project files. The CTO/DO Manager shall review COC forms on a monthly basis at a minimum. The data validators shall receive a copy also. The original COC/analytical request form shall be submitted by the laboratory along with the data delivered. Any changes to the analytical requests that are required shall be made in writing to the laboratory. A copy of this written change shall be sent to the data validators and placed in the project files. The reason for the change shall be included in the project files so that recurring problems can be easily identified.

7.0 HEALTH AND SAFETY

Not applicable.

8.0 REFERENCES

State of California Water Resources Control Board. 1988. Technical Guidance Manual for Solid Waste Water Quality Assessment Test (SWAT) Proposals and Reports.

USEPA. 1986. EPA NEIC Policies and Procedures, National Enforcement Investigations Center, Denver, Colorado.

USEPA. 1988. Guidance for Conducting Remedial Investigations and Feasibility Studies Under CERCLA (EPA USWER Directive 9355 3-01).

USEPA. 1992. RCRA Ground Water Monitoring Technical Enforcement Guidance Document (TEGD).

USEPA. 1995 and as updated. Test Methods for Evaluating Solid Waste (SW-846), Third edition.

9.0 ATTACHMENTS

1. Chain-of-Custody Seal
2. Generic Chain-of-Custody/Analytical Request Form
3. Sample Completed Chain-of-Custody/Analytical Request Form
4. Sample Out-of-Control Form

Attachment III-E-1

CHAIN-OF-CUSTODY SEAL

<i>[LABORATORY]</i>	SAMPLE NO.	DATE	SEAL BROKEN BY
	SIGNATURE		DATE
	PRINT NAME AND TITLE (<i>Inspector, Analyst or Technician</i>)		

Attachment III-E-3

SAMPLE COMPLETED CHAIN-OF-CUSTODY/
ANALYTICAL REQUEST FORM

Chain-of-Custody

Control Number: **96H0HC205** Date: 8 / 3 / 98 Page 1 of 1

① **Bill To:** CLEANIRAC Contractor ② **Sample Disposal:** by lab

③ **Company:** company name **Shipment Method:** Express Courier

④ **Address:** Oahu, Hawaii **Comments:** PACDIV Level D, Measure

⑤ **Container # (water):** 1 2 2 1 2 2 1 2 1 2 **Cooler Temperature at Lab:**

⑥ **GC Level:** PACDIV Level D **TAT:** Normal - per contract

⑦ **Sample ID (EPA ID):** (sample ID (Heavy MP Use Only)) **Date Collected:** **Time Collected:** **Lab ID:**

Sample ID (EPA ID)	Date Collected	Time Collected	Lab ID
HC205	9/6/96	9:35	
HC208	9/6/96	9:50	
HC207	9/6/96	10:15	
HC208	9/6/96	10:25	
HC209	9/6/96	10:45	
HC210	9/6/96	10:55	
HC211	9/6/96	12:50	

⑧ **Preservatives:** HCL HCL HNO3

⑨ **Matrix/OC:** Water Other (drum, sludge, etc.) Field Duplicate (MS/MSD)

Matrix/OC	TPH 8015B	CLP VOA	CLP SVOA	CLP Pesticides	CLP Metals	EPA 8080 (PCBs only)	EPA 8240	EPA 8270	Total Lead by EPA 6010	MS/MSD	Extr Volume	Hold	Total # of Containers
Water	X	X	X	X	X	X	X	X					1
Other (drum, sludge, etc.)	X	X	X	X	X	X	X	X					1
Field Duplicate (MS/MSD)	X	X	X	X	X	X	X	X					1
	X	X	X	X	X	X	X	X					1
	X	X	X	X	X	X	X	X					2
	X	X	X	X	X	X	X	X					8
TOTALS:	6	8	7	6	7	6	6	6					10

⑩ **Lab No.:** **For Lab Use:**

⑪ **Sampler Signature:** **Date:** **Time:**

⑫ **Relinquished By:** **Date:** **Time:**

⑬ **Received By:** **Date:** **Time:**

⑭ **Relinquished By:** **Date:** **Time:**

⑮ **Received By (LAB):** **Date:** **Time:**

⑯ **Original (white), Lab Copy (yellow), Field Copy (pink)**

⑰ **Does COC match sample:** Y or N
Broken container: Y or N
Received within holding time: Y or N
COC seal intact: Y or N
Any other problems: Y or N
If problems, Client contacted: Y or N
Date contacted: ____/____/____
Temperature (C): ____

Attachment III-E-4

SAMPLE OUT-OF-CONTROL FORM

OUT OF CONTROL FORM	Status	Date	Initial
	Noted OOC		
	Submit for CA*		
	Resubmit for CA*		
	Completed		

Date Recognized:		By:		Samples Affected (List by Accession AND Sample No.)
Dated Occurred:		Matrix		
Parameter (Test Code):		Method:		
Analyst:		Supervisor:		
1. Type of Event (Check all that apply)		2. Corrective Action (CA)* (Check all that apply)		
<input type="checkbox"/>	Calibration Corr. Coefficient <0.995	<input type="checkbox"/>	Repeat calibration	
<input type="checkbox"/>	%RSD>20%	<input type="checkbox"/>	Made new standards	
<input type="checkbox"/>	Blank >MDL	<input type="checkbox"/>	Reran analysis	
<input type="checkbox"/>	Does not meet criteria:	<input type="checkbox"/>	Sample(s) redigested and rerun	
<input type="checkbox"/>	Spike	<input type="checkbox"/>	Sample(s) reextracted and rerun	
<input type="checkbox"/>	Duplicate	<input type="checkbox"/>	Recalculated	
<input type="checkbox"/>	LCS	<input type="checkbox"/>	Cleaned system	
<input type="checkbox"/>	Calibration Verification	<input type="checkbox"/>	Ran standard additions	
<input type="checkbox"/>	Standard Additions	<input type="checkbox"/>	Notified	
<input type="checkbox"/>	MS/MSD	<input type="checkbox"/>	Other (please explain)	
<input type="checkbox"/>	BS/BSD			
<input type="checkbox"/>	Surrogate Recovery			
<input type="checkbox"/>	Calculations Error			
<input type="checkbox"/>	Holding Times Missed			
<input type="checkbox"/>	Other (Please explain	Comments:		

3. Results of Corrective Action	
<input type="checkbox"/>	Return to Control (indicated with)
<input type="checkbox"/>	Corrective Actions Not Successful - DATA IS TO BE FLAGGED with _____.

Analyst:	Date:
Supervisor:	Date:
QA Department:	Date:

SAMPLE HANDLING, STORAGE, AND SHIPPING

1.0 PURPOSE

This standard operating procedure (SOP) sets forth the methods for use by U.S. Navy PACDIV IRP field personnel engaged in handling, storing, and transporting samples.

2.0 SCOPE

This procedure applies to all samples, and sample containers handled, stored, shipped, or otherwise transported during Navy PACDIV IRP CTO/DO Activities.

This procedure shall serve as management-approved professional guidance for the U.S. Navy PACDIV IRP. It is not intended to obviate the need for professional judgment that may arise in unforeseen circumstances. Deviations from this procedure in planning or in the execution of planned activities must be approved by the CTO/DO Manager and Technical Director/QA Program Manager.

3.0 DEFINITIONS

None.

4.0 RESPONSIBILITIES

The Field Manager is responsible for ensuring that all samples are shipped according to this procedure.

The CTO/DO Manager and the Laboratory Project Manager are responsible for identifying instances of non-compliance with this procedure and ensuring that future sample transport activities are in compliance with this procedure.

The U.S. NAVY PACDIV IRP Technical Director is responsible for ensuring that sample handling, storage, and transport activities conducted during all CTO/DOs are in compliance with this procedure.

5.0 PROCEDURE

5.1 HANDLING AND STORAGE

Immediately following collection, all samples will be labeled according to the procedures in SOP III-E, *Record Keeping, Sample Labeling, and Chain-of-Custody Procedures*. The lids of the containers shall not be sealed with duct tape, but may be covered with custody seals or placed directly into self-sealing bags. The sample containers shall be placed in an insulated cooler with frozen gel packs (such as "blue ice") or ice in double, sealed self-sealing bags. Samples should occupy the lower portion of the cooler, while the ice should occupy the upper portion. Styrofoam pads shall be placed on the bottom and top (and optionally on the sides) of the inside of the cooler. An absorbent material (e.g., proper absorbent cloth material) shall be placed on the bottom of the cooler to contain liquids in case of spillage. All empty space between sample containers shall be filled with Styrofoam "peanuts" or other appropriate material. Prior to shipping, glass sample containers should be wrapped on the sides, tops, and bottoms with bubble wrap or other appropriate padding and/or surrounded by Styrofoam to prevent breakage during transport. All glass containers for water samples must be packed in a upright position, never stacked or on their sides. Prior to shipment, the ice or cold packs in the coolers shall be replaced so that samples will be maintained as close to 4°C as possible from the time of collection through transport of the samples to the analytical laboratory. Samples shall be shipped within 24 hours or on a schedule allowing the laboratory to meet holding times for analyses. The procedures for maintaining sample temperatures at 4°C, pertains to all field samples.

5.2 SHIPPING

All appropriate U.S. Department of Transportation (DOT) regulations (e.g., 49 Code of Federal Regulations (CFR), Parts 171-179) shall be followed in shipment of air, soil, water, and other samples. Elements of these procedures are summarized below.

In Hawaii, soil sample shipments are typically brought to the courier at the airport where a United States Department of Agriculture (USDA) representative is contacted by the courier to make an inspection. Alternatively, U.S. Navy PACDIV IRP has received approval from the USDA to ship soil samples, and has received a stamp that can be used to facilitate shipment. In this way, the USDA does not need to inspect each soil sample shipment. Water sample shipments do not need to be inspected by the USDA. Custody

seals are to be placed on each container (see Section 5.1, *Handling and Storage*) to ensure proper chain-of-custody control in the event coolers are opened for inspection.

In Guam, the courier picks up shipments at each site provided that arrangements have been made regarding pick-up time and location. Alternatively, shipments can be delivered directly to the courier at the airport. USDA inspection occurs outside of Guam.

5.2.1 Hazardous Materials Shipment

Field personnel must state whether any sample is suspected to be a hazardous material. A sample should be assumed to be hazardous unless enough evidence exists to indicate it is nonhazardous. If not suspected to be hazardous, shipments may be made as described in the Section 5.2.2 for non-hazardous materials. If hazardous, the procedures summarized below must be followed.

Any substance or material that is capable of posing an unreasonable risk to life, health, or property when transported is classified as hazardous. Hazardous materials identification should be performed by checking the list of dangerous goods for that particular mode of transportation. If not on that list, materials can be classified by checking the Hazardous Materials Table (49 CFR 172.102 including Appendix A) or by determining if the material meets the definition of any hazard class or division (49 CFR Part 173), as listed in Attachment 2.

All persons offering for shipment any hazardous material must be properly trained in the appropriate regulations, as required by HM-126F, Training for Safe Transportation of Hazardous Materials. The training covers loading, unloading, handling, storing, and transporting of hazardous materials, as well as emergency preparedness in the case of accidents and transportation security. Carriers such as commercial couriers must also be trained. Modes of shipment include air, highway, rail, and water.

When shipping hazardous materials, including bulk chemicals or samples suspected of being hazardous, the proper shipping papers (49 CFR 172 Subpart C), package marking (49 CFR 172 Subpart D), labeling (49 CFR 172 Subpart E), placarding (49 CFR 172 Subpart F, generally for carriers), and packaging must be used. Attachment III-F-1 shows an example of proper package markings. A copy of 49 CFR should be referred to each time a hazardous material/potentially hazardous samples are shipped.

According to Section 2.7 of the International Air Transport Association (IATA) Dangerous Goods Regulations publication, very small quantities of certain dangerous goods may be transported without certain marking and documentation requirements as described in 49 CFR Part 172. However, other labeling and packing requirements must still be followed. Attachment III-F-2 shows the volume or weight for different classes of substances. A "Dangerous Goods in Excepted Quantities" label must be completed and attached to the associated shipping cooler (Attachment 3). Certain dangerous goods are not allowed on certain airlines in any quantity.

As stated in item 4 of Attachment 4, the Hazardous Materials Regulations do not apply to hydrochloric acid (HCl), nitric acid (HNO₃), sulfuric acid (H₂SO₄), and sodium hydroxide (NaOH) added to water samples if their pH or percentage by weight criteria are met. These samples may be shipped as non-hazardous materials as discussed below.

5.2.2 Non-hazardous Materials Shipment

If the samples are suspected to be nonhazardous, based on previous site sample results, field screening results, or visual observations, if applicable, then samples may be shipped as nonhazardous.

When a cooler is ready for shipment to the laboratory, two copies of the chain-of-custody form shall be placed inside a self-sealing bag and taped to the inside of an insulated cooler. The coolers will then be sealed with waterproof tape and labeled "Fragile," "This-End-Up" (or directional arrows pointing up), or other appropriate notices. Chain-of-custody seals will be placed on the coolers as discussed in SOP III-E, *Record Keeping, Sample Labeling, and Chain-of-Custody Procedures*.

5.2.3 Shipments from Outside the Continental United States

Shipment of sample coolers to the U.S. from locations outside the continental U.S. is controlled by the USDA and is subject to their inspection and regulation. Documentation is required to prove that the receiving analytical laboratory is certified by the USDA to receive and properly dispose of soil; this is called a "USDA Soil Import Permit." In addition, all sample coolers must be inspected by a USDA representative, affixed with a label indicating that the coolers contain environmental samples, and shipping forms stamped by the USDA inspector prior to shipment. In addition, samples shipped from

U.S. territorial possessions or foreign countries must be cleared by the U.S. Customs Service upon entry into the United States. As long as the commercial invoice is properly completed (see below), shipments typically pass through U.S. Customs without the need to open coolers for inspection.

Completion and use of proper paperwork will, in most cases, minimize or eliminate the need of the USDA and U.S. Customs to inspect the contents. Attachment III-F-5 shows an example of how paperwork may be placed on the outside of coolers for nonhazardous materials. For hazardous materials, refer to Section 5.2.1.

In summary, the paperwork listed below should be taped to the outside of the coolers to assist sample shipments. If a shipment is made up of multiple pieces (e.g., more than one cooler), the paperwork need be attached only to one cooler, provided that the courier agrees. All other coolers in the shipment need only be taped and have address and chain-of-custody seals affixed.

1. **Courier Shipping Form & Commercial Invoice** - See Attachments III-F-6, III-F-7, and III-F-8 for examples of the information to be included on these forms. Both forms should be placed inside a clear plastic adhesive-backed pouch which adheres to the package (typically supplied by the courier) and placed on the cooler lid as shown in Attachment 5.
2. **Soil Import Permit and USDA Letter** (soil only) - See Attachments III-F-9 and III-F-10 for examples. The laboratory shall supply these documents prior to mobilization. The USDA in Hawaii often does stop shipments of soil without these documents. The 2" x 2" USDA label (described below), the USDA letter, and soil impact permit should be stapled together and placed inside a clear plastic pouch. Clear plastic adhesive-backed pouches which adhere to the package are typically supplied by the courier.

The Soil Import Permit label should be supplied by the laboratory. Original labels are preferred, but copies of this label which are cut out to the 2" x 2" dimensions are acceptable. Placing one label as shown in Attachment 5 (covered with clear packing tape) and one stapled to the actual permit is suggested.

Water samples are not controlled by the USDA, so the requirements for soil listed above do not apply.

3. **Chain-of-Custody Seals.** Seals should be supplied by the laboratory. CTO/DO personnel must sign and date these; at least two seals should be placed in such a manner that they stick to both the cooler lid and body. Placing the seals over the tape (as shown in Attachment 5), then covering it with clear packing tape, is suggested. This prevents the seal from coming loose and enables detection of tampering.
4. **Address Label.** A label stating the destination (laboratory address) should be affixed to each cooler.
5. **Special Requirements for Hazardous Materials** - see Section 5.2.1.

Upon receipt of sample coolers at the laboratory, the sample custodian shall inspect the sample containers as discussed in SOP III-E, *Record Keeping, Sample Labeling, and Chain-of-Custody Procedures*. The samples shall then be either immediately extracted and/or analyzed, or stored in a refrigerated storage area until they are removed for extraction and/or analysis. Whenever the samples are not being extracted or analyzed, they shall be returned to refrigerated storage.

6.0 RECORDS

Records shall be maintained as required by implementing these procedures.

7.0 HEALTH AND SAFETY

1. Avoid lifting heavy coolers with back muscles; instead, use leg muscles or dollies.
2. Wear proper gloves, such as blue nitrile, latex, etc., as defined in the site-specific project Health and Safety Plan, when handling sample containers to avoid contacting any materials that may have spilled out of the sample containers.

8.0 REFERENCES

SOP III-E, *Record Keeping, Sample Labeling, and Chain-of-Custody Procedures*

9.0 ATTACHMENTS

1. Example Package Marking
2. Packing Groups
3. Label for Dangerous Goods in Excepted Quantities
4. SW-846 Preservative Exception
5. Sample Cooler Marking Figure
6. Example Courier Form
7. Commercial Invoice - Soil
8. Commercial Invoice - Water
9. Soil Import Permit
10. Soil Samples Restricted Entry Labels

Attachment III-F-1

EXAMPLE HAZARDOUS MATERIAL PACKAGE MARKING

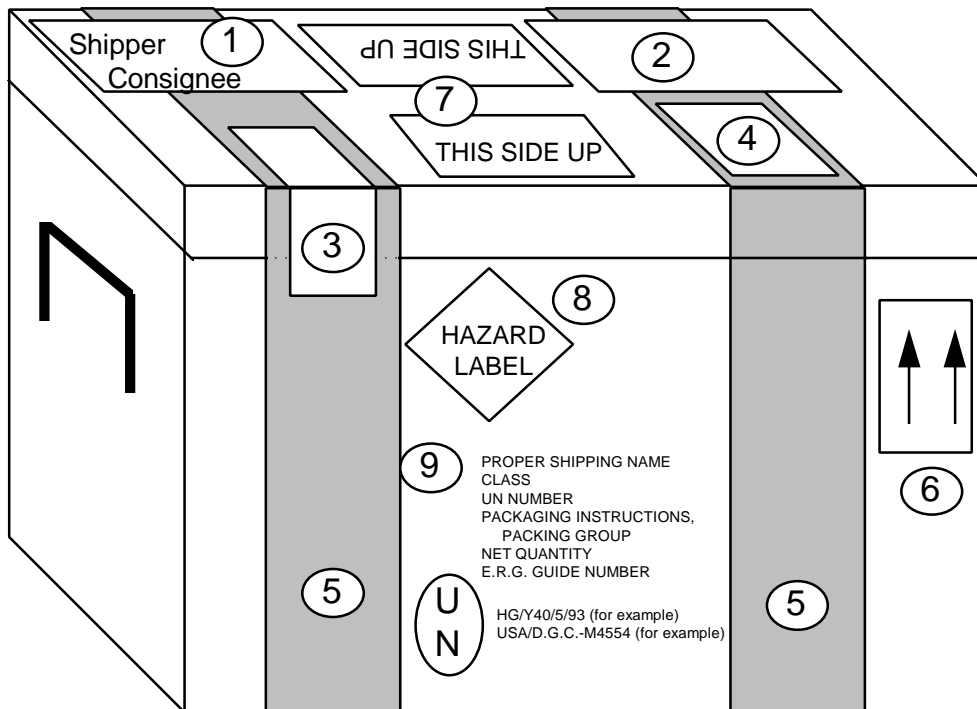

- | | |
|--|---|
| ① AIR BILL/COMMERCIAL INVOICE | ⑥ DIRECTION ARROWS STICKER - TWO REQUIRED |
| ② USDA PERMIT (Letter to Laboratory from USDA) | ⑦ THIS SIDE UP STICKERS |
| ③ CUSTODY SEAL | ⑧ HAZARD LABEL |
| ④ USDA 2" X 2" SOIL IMPORT PERMIT | ⑨ HAZARDOUS MATERIAL INFORMATION |
| ⑤ WATERPROOF STRAPPING TAPE | ⑩ PACKAGE SPECIFICATIONS |

Attachment III-F-2

PACKING GROUPS

PACKING GROUP OF THE SUBSTANCE CLASS or DIVISION of PRIMARY or SUBSIDIARY RISK	PACKING GROUP I Packagings		PACKING GROUP II Packagings		PACKING GROUP III Packagings	
	Inner	Outer	Inner	Outer	Inner	Outer
1: Explosives	----- Forbidden ^(Note A) -----					
2.1: Flammable Gas	----- Forbidden ^(Note B) -----					
2.2: Non-Flammable, non-toxic gas	----- See Notes A and B -----					
2.3: Toxic gas	----- Forbidden ^(Note A) -----					
3. Flammable liquid	30 mL	300 mL	30 mL	500 mL	30 mL	1 L
4.1 Self-reactive substances	Forbidden		Forbidden		Forbidden	
4.1: Other flammable solids	Forbidden		30 g	500 g	30 g	1 kg
4.2: Pyrophoric substances	Forbidden		Not Applicable		Not Applicable	
4.2 Spontaneously combustible substances	Not Applicable		30 g	500 g	30 g	1 kg
4.3: Water reactive substances	Forbidden		30 g or 30 mL	500 g or 500 mL	30 g or 30 mL	1 kg or 1 L
5.1: Oxidizers	Forbidden		30 g or 30 mL	500 g or 500 mL	30 g or 30 mL	1 kg or 1 L
5.2: Organic peroxides ^(Note C)	See Note A		30 g or 30 mL	500 g or 250 mL	Not Applicable	
6.1: Poisons - Inhalation toxicity	Forbidden		1 g or 1 mL	500 g or 500 mL	30 g or 30 mL	1 kg or 1 L
6.1: Poisons - oral toxicity	1 g or 1 mL	300 g or 300 mL	1 g or 1 mL	500 g or 500 mL	30 g or 30 mL	1 kg or 1 L
6.1: Poisons - dermal toxicity	1 g or 1 mL	300 g or 300 mL	1 g or 1 mL	500 g or 500 mL	30 g or 30 mL	1 kg or 1 L
6.2: Infectious substances	----- Forbidden ^(Note A) -----					
7: Radioactive material ^(Note D)	----- Forbidden ^(Note A) -----					
8: Corrosive materials	Forbidden		30 g or 30 mL	500 g or 500 mL	30 g or 30 mL	1 kg or 1 L
9: Magnetized materials	----- Forbidden ^(Note A) -----					
9: Other miscellaneous materials ^(Note E)	Forbidden		30 g or 30 mL	500 g or 500 mL	30 g or 30 mL	1 kg or 1 L

Note A: Packing groups are not used for this class or division.

Note B: For inner packagings, the quantity contained in receptacle with a water capacity of 30 mL. For outer packagings, the sum of the water capacities of all the inner packagings contained must not exceed 1 L.

Note C: Applies only to Organic Peroxides when contained in a chemical kit, first aid kit or polyester resin kit.

Note D: See 6.1.4.1, 6.1.4.2 and 6.2.1.1 through 6.2.1.7, radioactive material in excepted packages.

Note E: For substances in Class 9 for which no packing group is indicated in the List of Dangerous Goods, Packing Group II quantities must be used.

Attachment III-F-3

LABEL FOR DANGEROUS GOODS IN EXCEPTED QUANTITIES

DANGEROUS GOODS IN EXCEPTED QUANTITIES

This package contains dangerous goods in excepted small quantities and is in all respects in compliance with the applicable international and national government regulations and the IATA Dangerous Goods Regulations.

Signature of Shipper

Title

Date

Name and address of Shipper

This package contains substance(s) in Class(es)
(check applicable box(es))

Class: 2 3 4 5 6 8 9

and the applicable UN Numbers are:

Attachment III-F-4

PRESERVATIVE EXCEPTION

<u>Measurement</u>	<u>Vol. Req.</u> (mL)	<u>Container</u> ²	<u>Preservative</u> ^{3,4}	<u>Holding Time</u> ⁵
MBAS	250	P,G	Cool, 4°C	48 Hours
NTA	50	P,G	Cool, 4°C	24 Hours

1. More specific instructions for preservation and sampling are found with each procedure as detailed in this manual. A general discussion on sampling water and industrial wastewater may be found in ASTM, Part 31, p. 72-82 (1976) Method D-3370.
2. Plastic (P) or Glass (G). For metals, polyethylene with a polypropylene cap (no liner) is preferred.
3. Sample preservation should be performed immediately upon sample collection. For composite samples each aliquot should be preserved at the time of collection. When use of an automated sampler makes it impossible to preserve each aliquot, then samples may be preserved by maintaining at 4°C until compositing and sample splitting is completed.
4. When any sample is to be shipped by common carrier or sent through the United States Mail, it must comply with the Department of Transportation Hazardous Materials Regulations (49 CFR Part 172). The person offering such material for transportation is responsible for ensuring such compliance. For the preservation requirements of Table 1, the Office of Hazardous Materials, Materials Transportation Bureau, Department of Transportation has determined that the Hazardous Materials regulations do not apply to the following materials: Hydrochloric acid (HCl) in water solutions at concentration of 0.04% by weight or less (pH about 1.96 or greater); Nitric acid (HNO₃) in water solutions at concentrations of 0.15% by weight or less (pH about 1.62 or greater); Sulfuric acid (H₂SO₄) in water solutions at concentrations of 0.35% by weight or less (pH about 1.15 or greater); Sodium hydroxide (NaOH) in water solutions at concentrations of 0.080% by weight or less (pH about 12.30 or less).
5. Samples should be analyzed as soon as possible after collection. The times listed are the maximum times that samples may be held before analysis and still considered valid. Samples may be held for longer periods only if the permittee, or monitoring laboratory, has data on file to show that the specific types of sample under study are stable for the longer time, and has received a variance from the Regional Administrator. Some samples may not be stable for the maximum time period given in the table. A permittee, or monitoring laboratory, is obligated to hold the sample for a shorter time if knowledge exists to show this is necessary to maintain sample stability.
6. Should only be used in the presence of residual chlorine.

Attachment III-F-5

**NON-HAZARDOUS MATERIAL COOLER MARKING FIGURE FOR
SHIPMENT FROM OUTSIDE THE CONTINENTAL UNITED STATES**

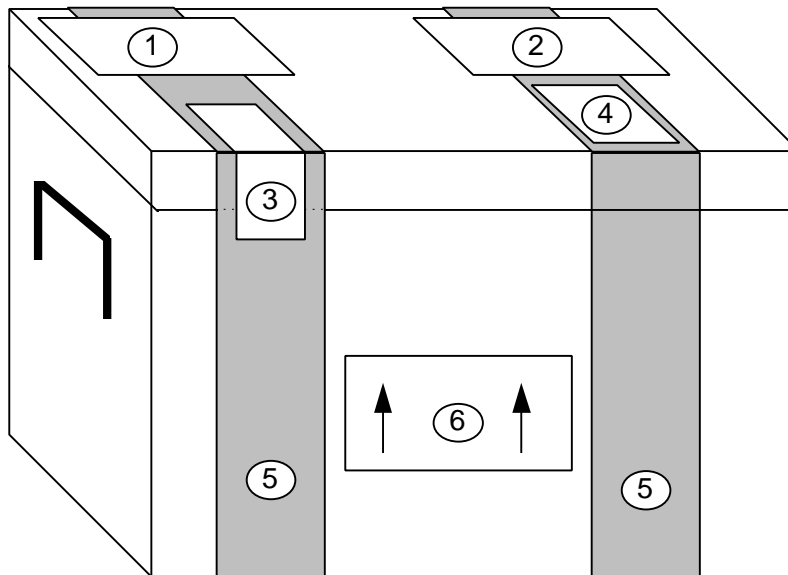

- ① AIR BILL/COMMERCIAL INVOICE
- ② USDA PERMIT (Letter to Laboratory from USDA)
- ③ CUSTODY SEAL
- ④ USDA 2" X 2" SOIL IMPORT PERMIT
- ⑤ WATERPROOF STRAPPING TAPE
- ⑥ DIRECTION ARROWS STICKER - TWO REQUIRED

Attachment III-F-6

EXAMPLE COURIER FORM

FedEx USA Airbill FedEx Tracking Number **801704855619**

0200 Form I.D. No. **SPL 11**
Sender's Copy

1 From (please print and press hard)

Date _____ Sender's FedEx Account Number _____ **Account Number**

Sender's Name **Joe Smith** Phone **(808) 545-2462**

Company **OGDEN ENVIRONMENTAL/CRC ACCT**

Address **680 IWILEI RD STE 660** Dept./Room/Suite/Room _____

City **HONOLULU** State **HI** ZIP **96817**

2 Your Internal Billing Reference Information
(Optional) (First 24 characters will appear on invoice) _____

3 To (please print and press hard)

Recipient's Name **Sample Receipt** Phone _____ **Lab Phone #**

Company _____ **Lab Name**

Address **Lab Address** Check here if residence (Only charge applies for FedEx Express Saver)

(To "HOLD" at FedEx location, print FedEx address here) (We Cannot Deliver to P.O. Boxes or P.O. ZIP Codes) Dept./Room/Suite/Room _____

City _____ State _____ ZIP _____

For HOLD at FedEx Location check here
 Hold Weekday (Not available with FedEx First Overnight)
 Hold Saturday (Not available at all locations; Available for FedEx Priority Overnight and FedEx 2Day only)

For Saturday Delivery check here
 (Extra Charge. Not available to all locations; Available for FedEx Priority Overnight and FedEx 2Day only)

Service Conditions, Declared Value, and Limit of Liability - By using this Airbill, you agree to the service conditions in our current Service Guide or U.S. Government Service Guide. Both are available on request. SEE BACK OF SENDER'S COPY OF THIS AIRBILL FOR INFORMATION AND ADDITIONAL TERMS. We will not be responsible for any claim in excess of \$100 per package whether the result of loss, damage, or delay, non-delivery, misdelivery, or misinformation, unless you declare a higher value, pay an additional charge, and document your actual loss in a timely manner. Your right to recover from us for any loss includes intrinsic value of the package, loss of sales, interest, profit, attorney's fees, costs, and other forms of damage, whether direct, incidental, consequential, or special, and is limited to the greater of \$100 or the declared value but cannot exceed actual documented loss. The maximum declared value for any FedEx Letter and FedEx Pak is \$500. Federal Express may, upon your request, and with some limitations, refund all transportation charges paid. See the FedEx Service Guide for further details.

4a Express Package Service Packages under 150 lbs. Delivery commitment may be later in some areas

FedEx Priority Overnight (Next business morning) FedEx Standard Overnight (Next business afternoon) FedEx 2Day* (Second business day) FedEx Express Saver* (Third business day)

FedEx First Overnight (Earliest next business morning delivery to select locations) (Higher rates apply) * FedEx Letter Rate not available. Minimum charge (See board rate).

4b Express Freight Service Packages over 150 lbs. Delivery commitment may be later in some areas

FedEx Overnight Freight (Next business day) FedEx 2Day Freight (Second business day) FedEx Express Saver Freight (Up to 3 business days)

(Call for delivery schedule. See back for detailed descriptions of freight services.)

5 Packaging FedEx Letter FedEx Pak FedEx Box FedEx Tube Other Declared value limit \$500

6 Special Handling

Does this shipment contain dangerous goods? Yes (We are attached to Shipper's Declaration) No (Shipper's Declaration not required)

Dry Ice (Dry Ice 3, UN 1845 or UN 1845) up to 50kg CA Cargo Aircraft Only (Dangerous Goods Shipper's Declaration not required)

7 Payment

Bill to: Sender (Account no. in section 7 will be billed) Recipient (Enter FedEx account no. or Credit Card no. below) Third Party Credit Card Cash/Check

FedEx Account No. _____ Exp. Date _____
Credit Card No. _____

Total Packages	Total Weight	Total Declared Value*	Total Charges
		\$.00	\$

*When declaring a value higher than \$100 per shipment, you pay an additional charge. See SERVICE CONDITIONS, DECLARED VALUE, AND LIMIT OF LIABILITY section for further information.

8 Release Signature Sign to authorize delivery without obtaining signature.

Your signature authorizes Federal Express to deliver this shipment without obtaining a signature and agrees to indemnify and hold harmless Federal Express from any resulting claims.

287

WGL 8827
Rev. Date 5/97
Part #02304
©1994 ST FedEx
PRINTED IN U.S.A.

Questions?
Call 1-800-Go-FedEx (800)463-3339

The World On Time

003520091 4

RETAIN THIS COPY FOR YOUR RECORDS

Attachment III-F-7

COMMERCIAL INVOICE - SOIL

DATE OF EXPORTATION 1/1/94			EXPORT REFERENCES (i.e., order no., invoice no., etc.) <CJO #>					
SHIPPER/EXPORTER (complete name and address) Joe Smith Ogden c/o <hotel name> <hotel address>			CONSIGNEE Sample Receipt <Lab Name> <Lab Address>					
COUNTRY OF EXPORT Guam, USA			IMPORTER - IF OTHER THAN CONSIGNEE					
COUNTRY OF ORIGIN OF GOODS Guam, USA								
COUNTRY OF ULTIMATE DESTINATION USA								
INTERNATIONAL AIR WAYBILL NO.						(NOTE: All shipments must be accompanied by a Federal Express International Air Waybill)		
MARKS/NOS	NO. OF PKGS	TYPE OF PACKAGING	FULL DESCRIPTION OF GOODS	QTY	UNIT OF MEASURE	WEIGHT	UNIT VALUE	TOTAL VALUE
	3	coolers	Soil samples for laboratory analysis only				\$1.00	\$3.00
		TOTAL NO. OF PKGS.				TOTAL WEIGHT		
		3					\$3.00	
Check one <input type="checkbox"/> F.O.B. <input type="checkbox"/> C&F <input type="checkbox"/> C.I.F.								

THESE COMMODITIES ARE LICENSED FOR THE ULTIMATE DESTINATION SHOWN.
DIVERSION CONTRARY TO UNITED STATES LAW IS PROHIBITED.

I DECLARE ALL THE INFORMATION CONTAINED IN THIS INVOICE TO BE TRUE AND CORRECT

SIGNATURE OF SHIPPER/EXPORTER (Type name and title and sign)

Joe Smith, Ogden

Joe Smith

1/1/94

Name/Title

Signature

Date

Attachment III-F-8

COMMERCIAL INVOICE - WATER

DATE OF EXPORTATION <i>1/1/94</i>				EXPORT REFERENCES (i.e., order no., invoice no., etc.) <i><CFO #></i>				
SHIPPER/EXPORTER (complete name and address) <i>Joe Smith Ogden c/o <hotel name> <hotel address></i>				CONSIGNEE <i>Sample Receipt <Lab Name> <Lab Address></i>				
COUNTRY OF EXPORT <i>Guam, USA</i>				IMPORTER - IF OTHER THAN CONSIGNEE				
COUNTRY OF ORIGIN OF GOODS <i>Guam, USA</i>								
COUNTRY OF ULTIMATE DESTINATION <i>USA</i>								
INTERNATIONAL AIR WAYBILL NO.					(NOTE: All shipments must be accompanied by a Federal Express International Air Waybill)			
MARKS/NOS	NO. OF PKGS	TYPE OF PACKAGING	FULL DESCRIPTION OF GOODS	QTY	UNIT OF MEASURE	WEIGHT	UNIT VALUE	TOTAL VALUE
	<i>3</i>	<i>coolers</i>	<i>Water samples for laboratory analysis only</i>				<i>\$1.00</i>	<i>\$3.00</i>
	TOTAL NO. OF PKGS. <i>3</i>					TOTAL WEIGHT		TOTAL INVOICE VALUE <i>\$3.00</i>
								Check one <input type="checkbox"/> F.O.B. <input type="checkbox"/> C&F <input type="checkbox"/> C.I.F.

THESE COMMODITIES ARE LICENSED FOR THE ULTIMATE DESTINATION SHOWN.
DIVERSION CONTRARY TO UNITED STATES LAW IS PROHIBITED.

I DECLARE ALL THE INFORMATION CONTAINED IN THIS INVOICE TO BE TRUE AND CORRECT

SIGNATURE OF SHIPPER/EXPORTER (Type name and title and sign)

Joe Smith, Ogden

Joe Smith

1/1/94

Name/Title

Signature

Date

SOIL IMPORT PERMIT
Attachment III-F-9

UNITED STATES DEPARTMENT OF AGRICULTURE
ANIMAL AND PLANT HEALTH INSPECTION SERVICE
PLANT PROTECTION AND QUARANTINE PROGRAMS

COMPLIANCE AGREEMENT

1. NAME AND MAILING ADDRESS OF PERSON OR FIRM Ogden Environmental & Energy Service Co. 680 Iwilei Road, Suite 660 Honolulu, HI 96817	2. LOCATION 680 Iwilei Road, Suite 660 Honolulu, HI 96817 Telephone: 545-2462 Fax: 528-5379
3. REGULATED ARTICLE(S) Foreign soil samples destined to approved laboratories in the Continental United States transiting through Honolulu International Airport and military facilities on Oahu, Hawaii.	
4. APPLICABLE FEDERAL QUARANTINE(S) OR REGULATIONS 7 CFR 330.300	

6. I/We agree to the following:

See the attached Addendum, Foreign Soil Samples Destined To Approved Laboratories In The Continental United States Transiting Through Honolulu International Airport And Military Facilities On Oahu, Hawaii

THIS COMPLIANCE AGREEMENT IS VALID FOR 2 YEARS FROM THE DATE OF ISSUANCE.
For renewal, call our office at 861-8446 or Fax 861-8450.

EXPIRATION DATE: SEPTEMBER 30, 2000

7. SIGNATURE <i>Betsy D. Aspangh</i>	8. TITLE Air & HAZARDOUS WASTE GROUP MANAGER	9. DATE SIGNED 9/9/98
The affixing of the signatures below will validate this agreement which shall remain in effect until canceled, but may be revised as necessary or revoked for noncompliance.		10. AGREEMENT NO. OAHU-ST-002
		11. DATE OF AGREEMENT September 2, 1998
12. PPQ OFFICIAL (Name and Title) Michael M. Jodoi, Supervisor, Satellite Operations	13. ADDRESS USDA, APHIS, PPQ 3375 Koapaka Street, Suite G330 Honolulu, HI 96819	
14. SIGNATURE <i>Michael M. Jodoi</i>		
15. STATE AGENCY OFFICIAL (Name and Title) N/A	16. ADDRESS N/A	
17. SIGNATURE N/A		

PPQ FORM 519
AUG. 1977

REPLACES PPQ 274, 519, 560, AND AQI 83, WHICH ARE OBSOLETE

Soil - Foreign/Foreign Soil - Transit Comp Agree Form 519.tsp

Attachment III-F-10

SOIL SAMPLES RESTRICTED ENTRY LABELS

**U.S. DEPARTMENT OF AGRICULTURE
ANIMAL AND PLANT HEALTH INSPECTION SERVICE
PLANT PROTECTION AND QUARANTINE
HYATTSVILLE, MARYLAND 20782**

**SOIL SAMPLES
RESTRICTED ENTRY**

The material contained in this package
is imported under authority of the
Federal Plant Pest Act of May 23, 1957.

For release without treatment if
addressee is currently listed as
approved by Plant Protection and
Quarantine.

PPQ FORM 550 *Edition of 12/77 may be used*
(JAN 83)

**U.S. DEPARTMENT OF AGRICULTURE
ANIMAL AND PLANT HEALTH INSPECTION SERVICE
PLANT PROTECTION AND QUARANTINE
HYATTSVILLE, MARYLAND 20782**

**SOIL SAMPLES
RESTRICTED ENTRY**

The material contained in this package
is imported under authority of the
Federal Plant Pest Act of May 23, 1957.

For release without treatment if
addressee is currently listed as
approved by Plant Protection and
Quarantine.

PPQ FORM 550 *Edition of 12/77 may be used*
(JAN 83)

**U.S. DEPARTMENT OF AGRICULTURE
ANIMAL AND PLANT HEALTH INSPECTION SERVICE
PLANT PROTECTION AND QUARANTINE
HYATTSVILLE, MARYLAND 20782**

**SOIL SAMPLES
RESTRICTED ENTRY**

The material contained in this package
is imported under authority of the
Federal Plant Pest Act of May 23, 1957.

For release without treatment if
addressee is currently listed as
approved by Plant Protection and
Quarantine.

PPQ FORM 550 *Edition of 12/77 may be used*
(JAN 83)

This page intentionally left blank.

LOGBOOKS

1.0 PURPOSE

This standard operating procedure (SOP) describes the activities and responsibilities of the U.S. Navy PACDIV IRP organization pertaining to the identification, use, and control of logbooks and associated field data records.

2.0 SCOPE

This document applies to all U.S. NAVY PACDIV IRP personnel involved with the use and control of logbooks and associated records pertaining to quality-related activities.

This procedure shall serve as management-approved professional guidance for the U.S. Navy PACDIV IRP. It is not intended to obviate the need for professional judgment that may arise in unforeseen circumstances. Deviations from this procedure in the planning or execution of activities must be approved by the CTO/DO Manager and Technical Director/QA Program Manager.

3.0 DEFINITIONS

3.1 LOGBOOK

A bound field notebook with consecutively numbered, water-repellent pages that is clearly identified with the name of the affected activity, the person assigned responsibility for maintenance of the logbook, and the beginning and ending dates of the entries.

3.2 DATA FORM

A predetermined format utilized for recording field data that may become, by reference, a part of the logbook. For example: soil boring logs, trenching logs, surface soil sampling logs, ground-water sample logs, and well construction logs are data forms.

4.0 RESPONSIBILITIES

The CTO/DO Manager is responsible for determining which team members shall record information in field logbooks and for obtaining and maintaining control of the required

logbooks. The Field Manager is responsible for ensuring that the logbook is completed properly and daily. The Field Manager is also responsible for submitting copies to the CTO/DO Manager, who is responsible for filing it and submitting a copy to the Navy (if required by the CTO/DO Statement of Work).

The logbook user is responsible for recording pertinent data into the logbook to satisfy project requirements and for attesting to the accuracy of the entries by dated signature. The logbook user is also responsible for safeguard of the logbook while having custody of it.

The Technical Director/QA Program Manager or designee is responsible for reviewing logbook entries to determine compliance with this procedure and to ensure that the entries are adequate to meet the project requirements.

5.0 PROCEDURE

The field logbook serves as the primary record of field activities. Entries shall be made chronologically and in sufficient detail to allow the writer or a knowledgeable reviewer to reconstruct the applicable events. The logbook shall be stored in a clean location and used only when outer gloves used for personal protective equipment have been removed.

Individual data forms may be generated to provide systematic data collection documentation. Entries on these forms shall meet the same requirements as entries in the logbook and shall be referenced in the applicable logbook entry. Individual data forms shall reference the applicable logbook and page number. At a minimum, names of all samples collected shall be included in the logbook even if recorded elsewhere.

All field descriptions and observations are entered into the logbook, as described in Attachment 1, using indelible black ink.

Typical information to be entered includes, but is not limited to, the following:

- Date and time of all onsite activities
- Site location and description
- Weather conditions

- Field work documentation
- Descriptions of and rationale for approved deviations from the Work Plan or Field Sampling Plan
- Field instrumentation readings
- Personnel present
- Photograph references
- Sample locations
- Sample EPA number and sample identification, as described in SOP I-A-9, *Sample Naming*
- Sample naming
- Field QC sample information
- Field descriptions, equipment used, and field activities accomplished to reconstruct field operations
- Meeting information
- Important times and dates of telephone conversations, correspondence, or deliverables
- Field calculations
- PPE level
- Calibration records
- Subcontractors present
- Equipment decontamination procedures and effectiveness

The logbook shall reference data maintained in other logs, forms, etc. Entry errors shall be corrected by drawing a single line through the incorrect entry, then initialing and dating

this change. An explanation for the correction should be entered if the correction is for more than just a mistake.

Each entry or group of entries shall be signed or initialed by the person making the entry at least at the end of each day.

Logbook page numbers shall be entered on each page to facilitate identification of photocopies.

If a person's initials are used for identification, or if uncommon acronyms are used, these should be identified on a page at the beginning of the logbook.

At least weekly and preferably daily, the preparer shall photocopy and retain the pages completed during that session for backup. This will prevent loss of a large amount of information if the logbook is lost.

A technical review of each logbook shall be performed by a knowledgeable individual such as the Field Manager, CTO/DO Manager, or QC Supervisor, at a frequency commensurate with the level of activity (weekly is suggested, or at a minimum monthly. These reviews shall be documented by the dated signature of the reviewer on the last page or page immediately following the material reviewed.

6.0 RECORDS

The field logbook shall be retained as a permanent project record. If a particular CTO/DO requires submittal of photocopies of logbooks, this shall be performed as required. The field logbook shall be reviewed by the CTO/DO Manager on at least a monthly basis.

7.0 HEALTH AND SAFETY

In order to keep the logbook clean, it should be stored in a clean location and used only when outer gloves used for personal protective equipment have been removed.

8.0 REFERENCES

SOP I-A-9, *Sample Naming*

U.S. Navy PACDIV IRP, Quality Assurance Management Plan.

9.0 ATTACHMENTS

1. Description of Logbook Entries

Attachment 1

DESCRIPTION OF LOGBOOK ENTRIES

Logbook entries shall contain the following information, as applicable, for each activity recorded. Some of these details may be entered on data forms as described previously.

Name of Activity	For example, Asbestos Bulk Sampling, Charcoal Canister Sampling, Aquifer Testing.
Task Team Members and Equipment	Name all members on the field team involved in the specified activity. List equipment used by serial number or other unique identification, including calibration information.
Activity Location	Indicate location of sampling area as indicated in the Field Sampling Plan.
Weather	Indicate general weather and precipitation conditions.
Level of Personal Protective Equipment	The level of personal protective equipment (PPE), e.g., Level D, should be recorded.
Methods	Indicate method or procedure number employed for the activity.
Sample Numbers	Indicate the unique numbers associated with the physical samples. Identify QC samples.
Sample Type and Volume	Indicate the medium, container type, preservative, and the volume for each sample.
Time and Date	Record the time and date when the activity was performed (e.g., 0830/08/OCT/89). Use the 24-hour clock for recording the time and two digits for recording the day of the month and the year.
Analyses	Indicate the appropriate code for analyses to be performed on each sample, as specified in the Field Sampling Plan.
Field Measurements	Indicate measurements and field instrument readings taken during the activity.
Chain of Custody and Distribution	Indicate chain-of-custody for each sample collected and indicate to whom samples are transferred and the destination.

References	If appropriate, indicate references to other logs or forms, drawings or photographs employed in the activity.
Narrative (including time and location)	<p>Create a factual, chronological record of the team's activities throughout the day, including the time and location of each activity. Include descriptions of any general problems encountered and their resolution. Provide the names and affiliations of non-field team personnel who visit the site, request changes in activity, impact to the work schedule, requested information, or observe team activities. Record any visual or other observations relevant to the activity, the contamination source, or the sample itself.</p> <p>It should be emphasized that logbook entries are for recording data and chronologies of events. The logbook author must include observations and descriptive notations, taking care to be objective and recording no opinions or subjective comments unless appropriate.</p>
Recorded by	Include the signature of the individual responsible for the entries contained in the logbook and referenced forms.
Checked by	Include the signature of the individual who performs the review of the completed entries.

Date: February 2007

Appendix F - Standard Operating Procedure - Decontamination

This page intentionally left blank.

EQUIPMENT DECONTAMINATION

1.0 PURPOSE

The standard operating procedure (SOP) describes methods of equipment decontamination for use during site activities at U.S. Navy PACDIV IRP sites.

2.0 SCOPE

These procedures shall be followed during decontamination of field equipment used to sample environmental media.

This procedure shall serve as management-approved professional guidance for the U.S. Navy PACDIV IRP. It is not intended to obviate the need for professional judgment that may arise in unforeseen circumstances. Deviations from this procedure in the planning or execution of activities must be approved by the CTO/DO Manager and Technical Director/QA Program Manager.

3.0 DEFINITIONS

None.

4.0 RESPONSIBILITIES

The Field Manager is responsible for ensuring that all field equipment is decontaminated according to this procedure.

The CTO/DO Manager is responsible for identifying instances of non-compliance with this procedure and ensuring that decontamination activities are in compliance with this procedure.

The Technical Director/QA Program Manager is responsible for ensuring that decontamination activities conducted during all CTO/DOs are in compliance with this procedure.

5.0 PROCEDURES

Decontamination of equipment used in soil/sediment sampling, ground-water monitoring, well drilling and well development, as well as equipment used to sample ground water, surface water, sediment, waste, wipe, asbestos, and unsaturated zone is necessary to prevent cross-contamination and to maintain the highest integrity possible in collected samples. Planning a decontamination program requires consideration of the following factors:

- The location where the decontamination procedures will be conducted
- The types of equipment requiring decontamination
- The frequency of equipment decontamination
- The cleaning technique and types of cleaning solutions appropriate to the contaminants of concern
- The method for containing the residual contaminants and wash water from the decontamination process
- The use of a quality control measure to determine the effectiveness of the decontamination procedure

This subsection describes standards for decontamination, including the techniques to be used, frequency of decontamination, cleaning solutions, and effectiveness.

5.1 DECONTAMINATION AREA

An appropriate location for the decontamination area at a site shall be selected on the basis of the ability to control access to the area, the ability to control residual material removed from equipment, the need to store clean equipment, and the ability to restrict access to the area being investigated. The decontamination area shall be located an adequate distance away and upwind from potential contaminant sources to avoid contamination of clean equipment.

5.2 TYPES OF EQUIPMENT

Drilling equipment that must be decontaminated includes drill bits, auger sections, drill-string tools, drill rods, split barrel samplers, tremie pipes, clamps, hand tools, and steel cable. Decontamination of monitoring well development and ground-water sampling equipment includes submersible pumps, bailers, interface probes, water level meters, bladder pumps, air lift pumps, peristaltic pumps, and lysimeters. Other sampling equipment that requires decontamination includes, but is not limited to, hand trowels, hand augers, slide hammer samplers, shovels, stainless steel spoons and bowls, soil sample liners and caps, wipe sampling templates, COLIWASA samplers, and dippers. Equipment with a porous surface, such as rope, cloth hoses, and wooden blocks, cannot be thoroughly decontaminated and shall be properly disposed of after one use.

5.3 FREQUENCY OF EQUIPMENT DECONTAMINATION

Down-hole drilling equipment and equipment used in monitoring well development and purging shall be decontaminated prior to initial use and between each borehole or well. However, down-hole drilling equipment may require more frequent cleaning to prevent cross-contamination between vertical zones within a single borehole. When drilling through a shallow contaminated zone and installing a surface casing to seal off the contaminated zone, the drilling tools shall be decontaminated prior to drilling deeper. Ground-water sampling shall be initiated by sampling ground water from the monitoring well where the least contamination is suspected. All ground-water, surface water, and soil sampling devices shall be decontaminated prior to initial use and between collection of each sample to prevent the possible introduction of contaminants into successive samples.

5.4 CLEANING SOLUTIONS AND TECHNIQUES

Decontamination can be accomplished using a variety of techniques and fluids. The preferred method of decontaminating major equipment such as drill bits, augers, drill string, pump drop-pipe, etc., is steam cleaning. Steam cleaning is accomplished using a portable, high pressure steam cleaner equipped with a pressure hose and fittings. For this method, equipment shall be thoroughly steam washed and rinsed with potable tap water to remove particulates and contaminants.

A rinse decontamination procedure is acceptable for equipment such as bailers, water level meters, new and re-used soil sample liners, and hand tools. The decontamination procedure shall consist of the following: (1) wash with a non-phosphate detergent (alconox, liquinox, or other suitable detergent) and potable water solution, (2) rinse in a bath with potable water, (3) spray with isopropyl alcohol, (4) rinse in a bath with deionized or distilled water, and (5) spray with deionized or distilled water. If possible, equipment shall be disassembled prior to cleaning. A second wash should be added at the beginning of the process if equipment is very soiled.

Decontaminating submersible pumps requires additional effort because internal surfaces become contaminated during usage. These pumps shall be decontaminated by washing and rinsing the outside surfaces using the procedure described for small equipment or by steam cleaning. The internal surfaces shall be decontaminated by recirculating fluids through the pump while it is operating. This recirculation can be done using a relatively long (typically 4 feet) large diameter pipe (4-inch or greater) equipped with a bottom cap. The pipe shall be filled with the decontamination fluids, the pump placed within the capped pipe, and the pump operated while recirculating the fluids back into the pipe. The decontamination sequence shall include (1) detergent and potable water, (2) potable water rinse, (3) potable water rinse, and (4) deionized water rinse. The decontamination fluids shall be changed after each decontamination cycle.

Solvents other than isopropyl alcohol may be used, depending upon the contaminants involved. For example, if polychlorinated biphenyls (PCBs) or chlorinated pesticides are contaminants of concern, hexane may be used as the decontamination solvent. However, if samples are also to be analyzed for volatile organics, hexane shall not be used. In addition, some decontamination solvents have health effects that must be considered. Decontamination water shall consist of distilled or deionized water. Steam-distilled water shall not be used in the decontamination process as this type of water usually contains elevated concentrations of metals. Decontamination solvents to be used during field activities will be specified in CTO/DO Work Plans or Quality Assurance Project Plans (QAPPs).

Equipment used for measuring field parameters such as pH, temperature, specific conductivity, and turbidity shall be rinsed with deionized or distilled water after each measurement. New, unused soil sample liners and caps will also be washed with a fresh

detergent solution and rinsed with potable water followed by distilled or deionized water to remove any dirt or cutting oils that may be on them prior to use.

5.5 CONTAINMENT OF RESIDUAL CONTAMINANTS AND CLEANING SOLUTIONS

A decontamination program for equipment exposed to potentially hazardous materials requires a provision for catchment and disposal of the contaminated material, cleaning solution, and wash water.

When contaminated material and cleaning fluids must be contained from heavy equipment such as drill rigs and support vehicles, the area must be properly floored, preferably with a concrete pad that slopes toward a sump pit. If a concrete pad is impractical, planking can be used to construct solid flooring that is then covered by a nonporous surface and sloped toward a collection sump. If the decontamination area lacks a collection sump, plastic sheeting and blocks or other objects shall be used to create a bermed area for collection of equipment decontamination water. Items such as auger flights, which can be placed on metal stands or other similar equipment, should be situated on this equipment during decontamination to prevent contact with fluids generated by previous equipment decontamination. Clean equipment should be stored in a separate location to prevent recontamination. Decontamination fluids contained within the bermed area shall be collected and stored in secured containers as described below.

Catchment of fluids from the decontamination of lighter-weight drilling equipment and hand-held sampling devices shall be accomplished using wash buckets or tubs. The decontamination fluids shall be collected and stored onsite in secured containers such as DOT-approved drums until their disposition is determined by laboratory analytical results. Containers shall be labeled in accordance with SOP I-A-7, *IDW Management*.

5.6 EFFECTIVENESS OF DECONTAMINATION PROCEDURES

A decontamination program must incorporate quality control measures to determine the effectiveness of cleaning methods. Quality control measures typically include collection of equipment rinsate samples or wipe testing. Equipment rinsates consist of analyte-free water that has been poured over or through the sample collection equipment after its final decontamination rinse. Wipe testing is performed by wiping a cloth over the surface of the equipment after cleaning. Further descriptions of these samples and their required

frequency of collection is provided in SOP III-B, *Field QC Samples (Water, Soil)*. These quality control measures provide "after-the fact" information that may be useful in determining whether or not cleaning methods were effective in removing the contaminants of concern.

6.0 RECORDS

The decontamination process shall be described in the field logbook.

7.0 HEALTH AND SAFETY

It is the responsibility of the Onsite Health and Safety Coordinator (OHSC) to set up the site zones (i.e., exclusion, transition, and clean) and decontamination areas. Generally the decontamination area is located within the transition zone, upwind of intrusive activities, and serves as the area where both personnel and equipment are washed to minimize the spread of contamination into the clean zone. For equipment, a series of buckets are set up on a visqueen-lined bermed area. Separate spray bottles containing isopropyl alcohol (or alternative cleaning solvent as described in the CTO/DO Work Plan or Field Sampling Plan) and distilled water are used for final rinsing of equipment. Depending on the nature of the hazards and the site location, decontamination of heavy equipment such as augers, pump drop pipe, and vehicles may be accomplished using a variety of techniques.

Personnel responsible for equipment decontamination must wear the PPE specified in the site-specific Health and Safety Plan (HSP). Generally this includes at a minimum Tyvek[®] coveralls, steel-toed boots with boot covers or steel-toed rubber boots, safety glasses, ANSI-Standard hard hats, and hearing protection (if heavy equipment is in operation). It should be noted that air monitoring by the OHSC may result in an upgrade to the use of half-face respirators and cartridges in the decontamination area; therefore, this equipment must be available onsite. If safe alternatives are not achievable, site activities will be discontinued immediately.

In addition to the aforementioned precautions, the following safe work practices will be employed:

Chemical Hazards Associated With Equipment Decontamination

1. Avoid skin contact with and/or incidental ingestion of decontamination solutions and water.
2. Utilize PPE as specified in the site-specific HSP to maximize splash protection.
3. Refer to material safety data sheets (MSDSs), safety personnel, and/or consult sampling personnel regarding appropriate safety measures (i.e., handling, PPE - skin, respiratory, etc.).
4. Take necessary precautions when handling detergents and reagents.

Physical Hazards Associated With Equipment Decontamination

1. To avoid possible back strain, it is recommended that the decontamination area be raised 1 to 2 feet above ground level.
2. To avoid heat stress, over exertion, and exhaustion, it is a recommended that equipment decontamination be rotated among all site personnel.
3. Take necessary precautions when handling field sampling equipment.

8.0 REFERENCES

SOP I-A-7, IDW Management

SOP III-B, Field QC Samples (Water, Soil).

U.S. EPA Environmental Response Team. 1988. Response Engineering and Analytical Contract Standard Operating Procedures. U.S. EPA, Research Triangle Park, NC.

9.0 ATTACHMENTS

None.

This page intentionally left blank.

Date: February 2007

Appendix G – Quality Analytical Project Plan

Date: February 2007

This page intentionally left blank.

Appendix G

Red Hill Bulk Fuel Storage Facility Final– Quality Assurance Project Plan (QAPP)

Pearl Harbor, Hawaii

August 2007

Department of the Navy
Commander
Naval Facilities Engineering Command, Pacific
Pearl Harbor, HI 96860-3134



Indefinite Delivery/Indefinite Quantity Contract
Contract Number N62742-02-D-1802, CTO 007

Red Hill Bulk Fuel Storage Facility Final – Quality Assurance Protection Plan (QAPP)

Pearl Harbor, Hawaii

August 2007

Prepared for:



**Department of the Navy
Commander
Naval Facilities Engineering Command, Pacific
258 Makalapa Drive, Suite #100
Pearl Harbor, HI 96860-3134**

Prepared by:

**The Environmental Company, Inc.
1001 Bishop Street, Suite 1400
Honolulu, Hawaii 96813**

and

**AMEC Earth & Environmental, Inc.
3375 Koapaka Street, Suite F251
Honolulu, Hawaii 96819**

Prepared under:

**Indefinite Delivery/Indefinite Quantity Contract
Contract Number N62742-02-D-1802, CTO 007**

Table of Contents

	<u>Page</u>
1.0 INTRODUCTION	3
2.0 DATA QUALITY OBJECTIVES AND INDICATORS	4
2.1 Project Data Quality Objectives.....	4
2.2 Data Quality Indicators (DQIs).....	4
2.2.1 Precision	5
2.2.2 Accuracy	6
2.2.3 Representativeness.....	8
2.2.4 Comparability	8
2.2.5 Completeness	8
2.2.6 Sensitivity	8
3.0 SAMPLING DESIGN, FIELD PROCEDURES, AND CHAIN OF CUSTODY.....	9
4.0 SAMPLE COLLECTION AND PRESERVATION	9
5.0 QUALITY CONTROL PROCEDURES AND CORRECTIVE ACTIONS.....	10
5.1 Field Quality Control	10
5.1.1 Trip Blanks	10
5.1.2 Field Replicate Samples	10
5.1.3 Calibration Requirements	11
5.2 Laboratory Quality Control.....	11
5.2.1 Method Blanks.....	11
5.2.2 Laboratory Control Samples.....	11
5.2.3 Matrix Spike/Matrix Spike Duplicate.....	12
5.2.4 Laboratory Duplicates	12
5.2.5 Surrogate Spikes	13
5.2.6 Internal Standards	13
5.3 Instrument Calibration and Frequency.....	14
5.3.1 Standard Solutions	14
5.3.2 Balances	14
5.3.3 Refrigerators	15
5.3.4 Water Supply System	15
5.3.5 Laboratory and Field Instruments.....	15
5.3.6 Preventative Maintenance.....	17
6.0 Data Management Procedures	17
6.1 Data Reduction and Reporting.....	18
6.1.1 Field Data Reduction, Review, and Deliverables	18
6.1.2 Laboratory Data Reduction, Review, and Deliverables	18
6.2 Field Document Control and Records Management.....	21
6.3 Laboratory Document Control and Records Management	22

7.0	ASSESSMENT/OVERSIGHT	22
7.1	Performance and System Audits	22
7.2	Corrective Actions	23
	7.2.1 Field Corrective Action	24
	7.2.2 Laboratory Corrective Action	24
	7.2.3 Corrective Actions Following Data Evaluation	25
7.3	Reports	26
8.0	DATA REVIEW, VERIFICATION, VALIDATION, AND ASSESSMENT	26
8.1	Data Review	26
8.2	Validation and Data Quality Review of Project Analytical Data	26
	8.2.1 Data Quality Review	26
	8.2.2 Data Validation	27
8.3	Data Validation Report	27
8.4	Final Data Quality Assessment	27

List of Tables

Table 1-1	Analytical Methods
Table 2-1	Laboratory Methods LOD and RLs
Table 2-2	Sensitivity Goals
Table 4-1	Sample Containers, Preservatives, and Holding Times
Table 5-1	Laboratory Control Samples

1.0 INTRODUCTION

This Quality Assurance Project Plan (QAPP) has been prepared as a companion document to the Work Plan (WP) to support generation of groundwater and soil data under activities specified in the WP for the Red Hill Bulk Fuel Storage Facility (Site). This QAPP describes the policy, organization and functional activities necessary to collect data of known quality that will stand up to legal and scientific scrutiny. This includes defining data quality needs of the project, and the quality control, quality assurance, and data management activities needed to achieve these data quality needs. A sampling and analysis plan, including number type and location of samples are provided as Appendix A of the WP.

This QAPP has been prepared using guidance elements from the Hawaii State Department of Health document Technical Guidance Manual for Underground Storage Tank Closure and Release Response, Appendix 7B, Suggested Outline of a Quality Assurance Project Plan. It is intended for use only in conjunction with the Site WP and FSP. The WP describes project data quality objectives and intended use of data generated during this project. The field sampling program is addressed in Section 5 of the WP Sections 2 through 4 of the FSP and describes the proposed field procedures and analytical parameters. Naval Facilities (NAVFAC) approved Standard Operating Procedures (SOPs) for specific field tasks (e.g., monitoring well sampling) are included in the Project WP as Appendixes.

A summary of analytical methods and sample matrixes that will be used for the analysis of these samples is presented in **Table 1-1**.

2.0 DATA QUALITY OBJECTIVES AND INDICATORS

2.1 Project Data Quality Objectives

Project-level data quality objectives (DQOs) and Applicable or Relevant and Appropriate Requirements (ARARs) To Be Considered for data collected during this project are outlined in the WP. The ARARs are based on “TIER 1 ACTION LEVELS FOR GROUND WATER RAINFALL \leq 200 CM/YEAR, DRINKING WATER SOURCE THREATENED” for Site COPCs as detailed in Section 3 of the WP. The primary DQO supported by this QAPP is production of chemical analysis data of known and sufficient quality to support the project-level DQOs defined in Section 4 of the WP.

Definitive data are required to achieve the project-level DQOs, and strict adherences to requirements of this document are required so that the data are of known and sufficient quality. The data quality indicators (DQIs) discussed in the following section of this document will be used to control data quality; laboratory compliance with DQI goals, analytical methodology requirements, and good laboratory practice will be assessed during the data verification and validation procedure.

Field measurement of chemical and physical parameters and the subsequent results will be used to assess Site conditions for worker’s health and safety, to evaluate groundwater conditions for sample collection, and to screen for possible presence of any potential non-aqueous phase liquid (NAPL). Field measurement methodology is discussed in the SOPs. The tolerable limits on uncertainty and resulting decision errors are less stringent for field measurements than the limits for definitive data.

PARCC criteria and DQIs are described in detail in Section 2.2 of this document. **Table 2-1** provides a comprehensive summary of the desired detection limits, reporting limits and corresponding analytical objectives for precision and accuracy on a compound specific basis.

2.2 Data Quality Indicators (DQIs)

The DQIs presented in this section are: precision, accuracy, representativeness, comparability, completeness, sensitivity (PARCCS), and the additional indicator of

selectivity. PARCCS can be applied to both field and laboratory analytical measurements to ensure that data of known and appropriate quality are obtained to support specific decisions or regulatory actions. Selectivity is a data quality indicator that applies specifically to laboratory data to ensure that reported data are representative of the reported compound, and not of a positive or negative artifact. Discussion of the project DQIs in this QAPP will be limited to their application and goals for purposes of this project. Except where specified, the DQI goals discussed below are not intended to be used as criteria for acceptance or rejection of data, but rather as guidance to indicate when further evaluation of data quality is needed.

2.2.1 Precision

Precision is defined as the degree of agreement between or among independent, similar, or repeated measures. Precision will be measured as the relative percent difference (RPD) between duplicate analyses when analyte concentration is greater than five times the method reporting limit (MRL) or sample quantitation limit (SQL), and as an absolute concentration based on the MRL or SQL when analyte concentration is less than five times the MRL or SQL.

When analyte concentrations are more than five times the MRL or SQL, precision will be calculated as the RPD as follows:

$$\%RPD_i = \left(\frac{2 \times |O_i - D_i|}{(O_i + D_i)} \right) \times 100$$

Where:

$\%RPD_i$ = Relative percent difference for compound i

O_i = Concentration of compound i in original sample or MS

D_i = Concentration of compound i in duplicate sample or MSD

For laboratory precision, performance goals will be:

- RPD between duplicate blank spikes less than or equal to 20%.
- RPD between duplicate samples less than or equal to 30% for analyte concentrations greater than or equal to five times the MRL or SQL, and the absolute concentration difference less than or equal to the MRL or SQL for analyte concentrations less than five times the MRL or SQL.
- RPD between duplicate matrix spikes (MS) less than or equal to 30%.

If these goals are not met, the laboratory will investigate the cause of the DQI exceedance and include a discussion of the exceedance and any impact on data usability in the case narrative. If the cause of the DQI exceedance is determined to be laboratory error, the laboratory will reprepare and/or reanalyze the sample as appropriate.

Precision related to sample collection in the field will be monitored as the difference between field duplicates. The RPD between field duplicates for samples with analyte concentrations greater than the MRL or SQL will be less than or equal to 30% for aqueous and air samples and less than or equal to 40% for soil samples. The absolute concentration difference between duplicate samples with concentrations less than five times the MRL or SQL will be less than or equal to the corresponding MRL or SQL. If this DQI goal is exceeded, AMEC will investigate possible causes and will discuss the results of the investigation and any effect on data usability in the data quality evaluation report.

2.2.2 Accuracy

Accuracy is the amount of agreement between a measured value and the true value. It will be monitored as the percent recovery (%R) of the MS and/or the matrix spike duplicate (MSD), laboratory control samples (also known as blank spikes), and surrogate spike compounds. It will also be measured using the analytical results of instrument calibration and other laboratory internal standards.

Accuracy will be calculated as the %R of analytes as follows:

$$\%R_i = \left(\frac{Y_i}{X_i} \right) \times 100$$

Where:

$\%R_i$ = percent recovery for compound i

Y_i = measured analyte concentration in sample i
(measured - original sample concentration)

X_i = known analyte concentration in sample i

Project-specific DQI goals for each type of accuracy control sample are discussed below and will be applied unless an analytical method contains defined performance criteria for the DQI.

The DQI goal for organic analyte and surrogate spike recovery in laboratory control samples is 70% to 130% of the known value for all compounds. Recovery in this range should be routinely achievable as the spike is added to an interference-free matrix.

The DQI goal for inorganic analyte recovery in laboratory control samples is 80% to 120% of the known value for all compounds. Recovery in this range should be routinely achievable as the spike is added to an interference-free matrix.

The DQI goal for recovery of analytes and surrogate compounds spiked into the sample matrix is that recoveries outside the 60% to 140% recovery limits must be reflective of the sample matrix rather than laboratory procedural bias, and that all matrix-related recovery problems are adequately documented in the laboratory report and raw data. Compliance with this DQI goal will be assessed by comparison of analyte and surrogate recovery in the sample matrix to laboratory performance on method blanks and blank spikes, and by results of the data validation and data quality review process.

The DQI goal for recovery of inorganic analytes spiked into the sample matrix is that recoveries outside the 75% to 125% recovery limits must be reflective of the sample matrix rather than laboratory procedural bias, and that all matrix-related recovery problems are adequately documented in the laboratory report and raw data. Compliance

with this DQI goal will be assessed by comparison of analyte recovery in the sample matrix to laboratory performance on method blanks and blank spikes, and by results of the data validation and data quality review process.

2.2.3 Representativeness

Representativeness requires a more subjective evaluation, which includes evaluating the adequacy of the number of samples collected given specific Site conditions and approved sampling procedures.

2.2.4 Comparability

Comparability also requires the use of subjective evaluation which includes review of such elements as normalizing data to standard conditions, such as reporting concentrations in soil based on dry weight, and appropriate units, such as those required for comparison against regulatory standards. Data for each analytical method will be reported in consistent units for each sample matrix to maximize data comparability.

2.2.5 Completeness

For the field sampling effort, completeness will be determined by calculating the percentage of the actual samples taken versus the number of samples scoped for the project. The field sampling effort will be at least 90% complete.

For each analytical method, completeness will be determined by calculating the ratio of non-rejected data points to the number of data points requested for analyses. Data will be at least 90 percent complete. Completeness will be assessed through data validation of 10 percent (by matrix) of the analytical results and data quality review of the remaining analytical results.

2.2.6 Sensitivity

Sensitivity refers to the need for method reporting limits (MRLs) and method detection limits (MDLs) that are sufficiently low to meet project data needs. For water and solid data generated as part of activities specified in the work plan, the methods must be sensitive enough to produce data that are usable to support human health and ecological

risk assessment activities, to allow evaluation of contamination fate and transport, and to compare chemical concentrations to potentially applicable regulatory criteria.

The sensitivity goal is that MRL for each analyte be less than the Hawaii Tier 1 Action Level for Soil and Groundwater: Rainfall \leq 200 cm/year, Drinking Water Source Threatened. If the MRL cannot meet this goal, a secondary objective is that the MDL meet this goal.

A list of regulated compounds along with the applicable sensitivity goals is provided in **Table 2-2**.

3.0 SAMPLING DESIGN, FIELD PROCEDURES, AND CHAIN OF CUSTODY

Sampling design and field procedures for this project are discussed in detail in the Project WP. Observations of field activities related to data collection are integral to comprehensive data evaluation. Field forms and notes should be up to date with respect to: samples to be collected, sample Ids, QA/QC sample collection requirements, and where the samples are to be turned in for analysis.

Samples shall be maintained under customary chain of custody protocols while in the field, until receipt by the lab. Samples will be transported directly to the contract laboratory or back to a secure facility at the end of the sampling day, soil and water samples will be stored in refrigerators, and air samples will be stored at room temperature until shipped. Chain of custody forms will be retained with the respective samples at all times and signed and dated appropriately.

Samples shall be submitted to the Project laboratories in sample delivery groups (SDGs) of approximately 20 field samples or fewer, if there are not 20 samples to include. Grouping the samples in sets of 20 allows efficient reporting of results, and facilitates the data verification and validation process because laboratory batches and associated quality control are based on groups of 20 samples.

4.0 SAMPLE COLLECTION AND PRESERVATION

Sample locations, sample collection procedures, and sample preservation are specified in the FSP. A summary of the sampling requirements for each laboratory method including

laboratory containers, sample volumes, preservation, and holding times is provided as **Table 4-1**.

5.0 QUALITY CONTROL PROCEDURES AND CORRECTIVE ACTIONS

In order to attain data of sufficient quality to support project DQOs, specific procedures are required to allow evaluation of data quality. These procedures and requirements for their evaluation are described in this section.

5.1 Field Quality Control

Evaluation of field sampling procedures requires the collection and evaluation of field QC samples. Trip blanks and field replicates will be collected and submitted to the laboratory to provide a means of assessing the quality of data resulting from the field sampling program.

5.1.1 Trip Blanks

Trip blanks will be used to evaluate whether the shipping and handling procedures are introducing contaminants into the samples, and if cross-contamination in the form of VOC migration has occurred between the collected samples. One trip blank will be submitted to the laboratory for analysis each day that samples are collected for VOCs. Trip blanks will not be submitted for soil/rock samples because these samples will be submitted frozen, which will result in broken VOA vials due to thermal expansion. Trip blanks for water samples are VOA vials filled with purged deionized water that are transported to the field and then returned to the laboratory without being opened.

Trip blanks should not contain detectable concentrations of target analytes greater than the MRL for the compound. Any detection of target analytes in a trip blank will result in an investigation to determine effect on overall data usability, and affected results will be qualified as estimates or as nondetects at an elevated MRL as appropriate.

5.1.2 Field Replicate Samples

Field replicates are collocated samples that are collected simultaneously in separate containers. The purpose of field replicates is to allow evaluation of the contribution of

random error from sampling to the total error associated with the data. A minimum of one set of field replicates will be collected and submitted for every ten field samples collected. Field replicate precision will be evaluated as described in Section 2.2.1 above.

5.1.3 Calibration Requirements

Field-based analytical instruments, such as turbidometers and pH electrodes, must be calibrated following manufacturers' instructions and frequency recommendations (or following appropriate SOPs) before they may be used for data collection.

5.2 Laboratory Quality Control

Laboratory quality control samples are used to monitor the laboratory's precision and accuracy of the analytical procedure results. Laboratory QC samples are analyzed as part of the standard laboratory QC protocols and are accomplished through analyzing method blanks, laboratory control samples (blank spikes), surrogate spikes, and internal standards. Not all analyses require the above QC sample types. Typically, these QC samples are not required for non-SW-846 methods. Method specific laboratory QC samples are summarized in **Table 5-1**.

5.2.1 Method Blanks

Method blanks will be used to check the level of laboratory background contamination. Laboratory method blanks will be analyzed with each sample batch. Results will be compared to all samples in the analytical batch.

Quality control criteria require that no contaminants be detected in the blank(s) above the MRL. If an analyte is detected, the action taken will follow the laboratory SOPs and QAMs. Blank samples will be analyzed for the same parameters as the associated field samples.

5.2.2 Laboratory Control Samples

Laboratory control samples (LCS), also known as blank spikes (BS), are used to monitor the laboratory's day-to-day performance of routine analytical methods, independent of matrix effects. LCS are prepared by spiking reagent water (aqueous samples) or silica

sand (soil or sediment samples) with standard solutions prepared independently from those used in establishing instrument calibration. LCS must undergo the same preparation, cleanup (if used), and analyses as the associated field samples. Results are compared on a per-batch basis to pre-established control limits and are used to evaluate laboratory performance for precision and accuracy.

5.2.3 Matrix Spike/Matrix Spike Duplicate

MS and MSDs are used to evaluate analytical (preparation and analysis) precision and accuracy (Section 2.2.1 and Section 2.2.2). The MS/MSDs will be collected and analyzed at a rate of 5% of the primary samples for each analytical method and matrix or at least one for each analytical batch, whichever is greater.

Because MS/MSD samples measure the effect of a specific sample matrix on analyte recovery, only MS/MSD samples from this investigation will be analyzed, and not samples from other projects. The MS/MSD samples will be analyzed for the same parameters as the primary samples in the same QC analytical batch. Results will be expressed as a percent recovery of the known spiked amount and as a RPD for the MS/MSD pairs.

The goal for recovery of analytes spiked into the sample matrix is that recoveries less than 60% or greater than 140% for organic analytes; or less than 75% or greater than 125% for inorganic analytes must be reflective of the sample matrix rather than procedural bias, and that all matrix-related recovery problems are adequately documented in the laboratory report and in the raw data. Compliance with this goal will be assessed by comparison of analyte and surrogate recovery in the sample matrix with laboratory performance on method blanks and blank spikes.

5.2.4 Laboratory Duplicates

Precision of the analytical system is evaluated by using laboratory duplicates. Laboratory duplicates are two portions of a single homogeneous sample analyzed for the same parameters. Laboratory duplicates will be prepared and analyzed for all analytical batches requiring duplicates as specified per method in the laboratory QAMs.

Not all methods require laboratory duplicates and matrix spike duplicates are preferred for many organic methods. LCS duplicates will be prepared and analyzed for all batched when insufficient sample is collected for matrix spike duplicates. The RPD calculation (precision) is described in Section 2.2.1.

5.2.5 Surrogate Spikes

Surrogate spikes are used to evaluate accuracy, method performance, and extraction efficiency. Surrogate compounds are compounds not normally found in environmental samples; however, they are similar to the target analytes in chemical composition and behavior in the analytical process. Samples for organic analysis will be spiked with surrogate compounds consistent with the requirements described in the laboratory SOPs and QAMs.

Since sample characteristics will affect the percent recovery (R), percent R is a measurement of accuracy of the overall analytical method on each individual sample. The percent R of surrogates is calculated concurrently with the analytes of interest, using the equation in Section 2.2.2.

5.2.6 Internal Standards

Internal standards are used in GC/MS analyses. A constant amount of internal standard is added to all standards, samples, and extracts. The ratio of the peak area, height, or intensity of the target analyte to the peak area, height, or intensity of the internal standard in the sample or extract is compared to a similar ratio derived for each calibration standard. The target analyte response is calculated relative to that of the internal standard.

For GC/MS analyses of soil and water samples, internal standard areas or heights for all blanks, samples, and spikes must be 50 percent to 200 percent of the internal standard areas or heights from the last passing continuing calibration (CCAL). The laboratory must re-prepare and/or reanalyze any blank, sample, or spike that does not meet this DQI goal. If the internal standard area or height does not meet the DQI goal upon reanalysis, the laboratory must include a discussion of the possible cause and effect on data usability in the case narrative.

5.3 Instrument Calibration and Frequency

Analytical instrument calibration and maintenance will be conducted in accordance with the QC requirements identified in each laboratory SOP and quality assurance plan (QAP)/QAMs, USEPA guidance, and the instrument manufacturers' instructions. General requirements are discussed below.

5.3.1 Standard Solutions

A critical element in the generation of quality data is the purity/quality and traceability of the standard solutions and reagents used in the analytical operations. To ensure the highest purity possible, the primary reference standards and standard solutions will be obtained from the National Institute of Standards and Technology (NIST), the USEPA repository, or a reliable commercial source, and will be traceable to NIST Primary Reference Standards. The laboratories will maintain written records of the supplier, lot number, concentration, receipt date, preparation date, preparer's name, method of preparation, expiration date, and all other pertinent information for all standards, standard solutions, and individual standard preparation logs.

Standard solutions will be validated prior to use. Validation procedures can range from a check for chromatographic purity to verification of the concentration of the standard solution using another standard solution prepared at a different time or obtained from a different source. Stock and working standard solutions will be checked regularly for signs of deterioration, such as discoloration, formation of precipitates, or change of concentration. Care will be exercised in the proper storage and handling of standard solutions. All containers will be labeled as to compound, concentration, solvent, expiration date, and preparation data (initials of preparer/date of preparation). Reagents will be examined for purity by subjecting an aliquot or subsample to the corresponding analytical method.

5.3.2 Balances

Analytical balances will be calibrated annually according to manufacturer's instructions and have a daily calibration check against NIST Class I weights before use by laboratory

personnel. Balance calibration shall be documented in appropriate bound logbooks with pre-numbered pages.

5.3.3 Refrigerators

The refrigerators will be monitored for proper temperature by measuring and recording internal temperatures on a daily basis. At a minimum, thermometers used for these measurements will be calibrated annually, against a thermometer traceable to NIST.

5.3.4 Water Supply System

The laboratories will maintain an appropriate water supply system that is capable of furnishing American Society for Testing and Materials (ASTM) Type II polished water to the various analytical areas. This laboratory pure water shall not contain detectable concentrations of target analytes or interfering substances.

5.3.5 Laboratory and Field Instruments

Calibration of analytical instrumentation is required to ensure that the analytical system is operating correctly and functioning at the sensitivity required to meet project-specific DQOs. Each instrument will be calibrated with standard solutions appropriate to the instrument and analytical method, in accordance with the methodology specified and at the QC frequency specified in the laboratory SOPs.

The calibration and maintenance history of the laboratory instrumentation is an important aspect of the project's overall QA/QC program. As such, the initial calibration (ICAL), initial calibration verification (ICV) and continuing calibration verification (CCV) procedures will be implemented by trained personnel following the manufacturer's instructions and in accordance with applicable USEPA protocols to ensure the equipment is functioning within the tolerances established by the manufacturer and the method-specific analytical requirements.

Initial Calibration

ICAL of instruments used for the analysis of organic analytes in soil and water samples must be performed using a minimum of five standards for all single-component target analytes and surrogates.

- The relative standard deviation (RSD) shall be less than or equal to 15% for each compound included in the calibration standard, unless the criteria is superceded by method-specific acceptance limits, before an average response factor calibration may be considered valid. AMEC will not accept grand mean calibration models as valid for analytes that exceed RSD criteria.
- If RSD criteria cannot be met, linear or non-linear calibration models will be considered acceptable as long as the correlation coefficients are greater than or equal to 0.99.
- If a first order (linear) regression model is used for organic analytes, the line should not be forced through the origin, but have the intercept calculated from the five calibration points and the origin (0,0) must not be used as a fictitious calibration point. Additionally, the lowest calibration point must be at a concentration less than or equal to the method quantitation limit.
- If a second order (quadratic) model is used, six calibration standards instead of five must be analyzed. The curve must be continuous, continuously differentiable, and monotonic over the calibration range. The line must not be forced through the origin, but have the intercept calculated from the six calibration points. In addition, the origin (0,0) must not be included as a seventh calibration point.

Analytes with calibration models which cannot meet any of the above criteria may still be considered valid if AMEC has been notified in writing of the calibration difficulties before the start of analysis, and the laboratory qualified all affected data as estimated values.

ICAL of instruments used for the analysis of inorganic analytes will be conducted in accordance with the manufacturer's instructions and QC requirements identified in each laboratory SOP and QAM.

Initial Calibration Verification

Immediately after calibration, the analysis of an ICV standard containing the same analytes as the calibration standards, at a concentration close to the middle of the calibration range, and made from a different source, manufacturer, or lot number than the calibration standards will be required. ICV standards serve to verify the preparation and concentration of the instrument calibration standards. A single ICV is required each time the instrument is calibrated.

Continuing Calibration Verification

Continuing calibration verification (CCV – inorganic analyses) or continuing calibration (CCAL – organic analyses) standards will be analyzed (as per method requirements) to verify the calibration of the analytical system over time. If the response or calculated concentration for an analyte is within the method-specific acceptance limits of the response obtained during the initial calibration or the expected concentration, the curve is considered valid and analysis may proceed. Samples may not be analyzed unless the calibration curve is proven valid. Once verified, an organic ICAL is valid until a CCAL fails or significant instrument maintenance is performed. Calibration procedure frequency is summarized in **Table 5-1**.

5.3.6 Preventative Maintenance

Preventative maintenance on laboratory systems will be performed as needed. No project samples will be analyzed on a system that is not in good working order and properly calibrated.

6.0 Data Management Procedures

AMEC and the Project laboratories are responsible for generating, controlling, and archiving Project laboratory and field reports. This information should be maintained with a system that is effective for retrieval of any documentation that affected the reported results. This includes record generation and control, security, and maintenance for the project related documents.

6.1 Data Reduction and Reporting

The QA Officer, Project Chemist, and Database Manager will work together to perform the final review and approval of the data prior to its entry into the database system. This will include examining the results for field duplicates, matrix spike/matrix spike duplicates (MS/MSDs), laboratory blanks, and laboratory duplicates to ensure they are acceptable. This will also include comparing the sample descriptions with the field sheets for consistency and ensuring that any anomalies in the data are appropriately documented.

6.1.1 Field Data Reduction, Review, and Deliverables

Field data will be reviewed to a lesser degree than laboratory data. The Field Manager will debrief field personnel during sampling events and identify anomalous data or observations. The Field Manager will evaluate if any action needs to be taken and make recommendations to the Project Manager.

6.1.2 Laboratory Data Reduction, Review, and Deliverables

The Project laboratories shall deliver final tabulated results and EDDs by email or fax in no more than 14 days after receipt of the final sample in each SDG. Hardcopy data packages shall be received by TEC Inc. no later than 30 days after receipt of the samples by the Project laboratory.

It is possible that expedited turnaround time may be required on some project samples. If this is the case, it is expected that Project laboratories will make every reasonable effort to accommodate the expedited schedule, or assist TEC Inc. to identify a qualified laboratory that can meet the schedule.

Data generated by the Project laboratories will undergo data reduction and review procedures described in the laboratory QAMs and SOPs. Data generated, reduced, and reviewed by the laboratories will undergo a comprehensive data review by a QA reviewer or designee.

For all analyses, USEPA CLP equivalent Level IV deliverable requirements will be employed for documentation and reporting of all data. CLP report forms will not be required.

Laboratory Data Reduction

Each Project laboratory will perform in-house analytical reduction under the direction of the laboratory QA manager. Laboratory reduction procedures will be those adopted, where appropriate, from SW-846 (EPA, 1997 and updates) and those described in the QAM. The data reduction steps will be documented, signed, and dated by the analyst or designee. Data reduction will be conducted as follows:

- Raw data produced by the analyst will be processed and reviewed for attainment of QC criteria as outlined in this document and/or established EPA method for overall reasonableness and for calculation or transcription errors.
- Data will then be entered into the laboratory information management system (LIMS) and a computerized report will be generated and sent to the laboratory QA manager or designee for review.

Laboratory data reduction procedures will be those adopted, where appropriate, from Test Methods for Evaluation of Solid Waste, Physical/Chemical Methods, SW-846 (EPA, 1997 and updates), and those described in the laboratory QAMs. The data reduction steps will be documented, signed, and dated by the analyst.

Laboratory qualifiers as described and defined in the laboratory QAMs will include, but are not limited to:

- Concentrations below required reporting limits;
- Estimated concentrations due to poor spike recovery;
- Concentrations of the chemical also found in the laboratory blank; and
- Other sample-specific qualifiers necessary to describe QC conditions.

The laboratories will maintain detailed procedures for laboratory record keeping in order to support the validity of all analytical work. Each data report package submitted to the

TEC INC. Project Manager will contain the laboratory's written certification that the requested analytical method was run and that all QA/QC checks were performed. The laboratory program administrator will provide the TEC INC. Project Manager with QC reports of the laboratory's external audits, if appropriate, which will become part of the project file.

Laboratory Data Review

The laboratory data review process involves evaluation of both the results of the QC data and the professional judgment of the person(s) conducting the review. This application of technical knowledge and experience to the data evaluation is essential to ensuring that high quality data are generated. Each Project laboratory has documented procedures, which are to be followed and must be accessible to all laboratory personnel. The data review is generally conducted in a three-step process at the laboratory prior to submittal:

- Level 1 Analyst/Peer Data Review – The analysts review the quality of their work based on an established set of guidelines. The review will ensure at a minimum that: appropriate preparation, analysis, and SOPs have been followed; analytical results are correct and complete; QC samples are within established control limits; and that documentation is complete (e.g., any anomalies have been documented).
- Level 2 Supervisory Data Review – A supervisor or data review specialist whose function is to provide an independent review of the data package will perform this level of review. This review will also be conducted according to an established set of guidelines (i.e., method requirements and laboratory SOP). The Level 2 review includes a review of the qualitative and quantitative data and review of documented anomalies.
- Level 3 Administrative Data Review – A laboratory QA/QC officer or program administrator performs the final data review, prior to submittal. This level of review provides a total overview of the data package to ensure its consistency and compliance with project requirements.

The Project laboratory QA/QC officer or designee will evaluate the quality of the work based on this document and an established set of laboratory guidelines to ensure the following:

- Sample preparation information is correct and complete;
- Analysis information is correct and complete;
- Appropriate procedures have been followed;
- Analytical results are correct and complete;
- Laboratory QC check results are within appropriate QC limits;
- Special sample preparation and analytical requirements have been met;
- Documentation is complete (all anomalies in the preparation and analysis have been documented; holding times are documented); and
- Laboratory qualifiers have been assigned to all samples with data usability limitations.

Laboratory Data Deliverables

Upon acceptance of the data by the laboratory QC manager, or designee, deliverables will be generated and submitted to the TEC INC. Project Manager. The contract laboratory will maintain detailed procedures for laboratory record keeping, supporting the validity of all analytical work. Each data report package submitted to the TEC INC. Project Manager will contain the laboratory's written certification that the requested analytical method was run and that all laboratory QC checks were performed. The laboratory program administrator will provide the TEC INC. Project Manager with QC reports of their external audits, if appropriate, which will become part of the project file.

The Project laboratory will be required to report analytical results consistently. Analytical results for soils and solid samples will be reported in concentrations of micrograms per kilogram ($\mu\text{g}/\text{Kg}$) or milligrams per kilogram (mg/Kg). Analytical results for water samples will be reported in micrograms per liter ($\mu\text{g}/\text{L}$) or milligrams per liter (mg/L).

6.2 Field Document Control and Records Management

Project-specific records that relate to fieldwork performed will be retained for 5 years. These records may include correspondence, COC records, field notes, and reports issued

as a result of the work. In addition, records that document the field operations will be retained. This may include equipment performance records, maintenance logs, personnel files, general field procedures, and corrective action reports. Electronic or hard copy records of field operations are acceptable.

6.3 Laboratory Document Control and Records Management

The laboratory prepares and retains full analytical and QC documentation that can be tracked from initiation to disposal for each sample. The following minimum records should be stored for each project:

- Original work order, COC, and other pertinent documents received with the samples
- Communications between the laboratory, field, and the customer
- Any associated corrective actions
- Laboratory data packages
- GC/MS mass spectra for samples verified with analyst's initials
- Finalized data reports
- Laboratory log books
- GS/MS tune data, as applicable
- Electronic data

The laboratory should also maintain its QAP and related SOPs for the methods performed.

7.0 ASSESSMENT/OVERSIGHT

7.1 Performance and System Audits

Proper communication between field personnel, project management personnel, and laboratory personnel will help to ensure that the proper methods and techniques are used throughout the Project.

The QA Officer will be responsible for initiating audits, selecting the audit team, and overseeing audit implementation.

The Field Manager will be responsible for supervising and checking that samples are collected and handled in accordance with this QAPP and that documentation of work is adequate and complete.

The Project laboratory QA Managers will have the responsibility of ensuring that their analytical laboratory is following in-house performance and performing system audits under their in-house QA/QC guidelines. The laboratory will deal with any irregularities found in the laboratory's performance or system audits immediately. The laboratory QA Manager, or their designee, will also conduct the following internal audits regularly:

- Technical audit including reviews of calibration and equipment monitoring records, laboratory logbooks, maintenance records, and instrument control charts;
- Data quality audit reviews, including all aspects of data collection, reporting, and review; and
- Management systems audits verifying that management and supervisory staff are effectively implementing and monitoring all QC activities necessary to support the laboratory QA program.

The TEC INC. Project Manager is responsible for overseeing that the project performance satisfies the QA objectives as set forth in this document. Reports and technical correspondence will be peer reviewed by qualified individuals before being finalized.

7.2 Corrective Actions

Audits and other assessments may reveal findings of practices or procedures that do not conform to this QAPP. The following sections describe appropriate corrective actions for the various data management activities.

7.2.1 Field Corrective Action

The Field Manager will review the procedures being implemented in the field for consistency with the established protocols. Sample collection, preservation, labeling, etc. will be checked for completeness. Where procedures are not strictly in compliance with the established protocol, the deviations will be field documented and reported to the QA Officer. Corrective actions will be defined and documented, as appropriate, by the Field Manager and reported to the TEC INC. Project Manager and the QA Officer. The documentation will become part of the project file.

7.2.2 Laboratory Corrective Action

The Project laboratory QA Managers will be responsible for the review of the data generated by their laboratory to ensure that all QC samples have been run as specified in the protocol. Recoveries of LCS, surrogates, and MS samples will be reviewed for method accuracy. The RPD of laboratory duplicates and MSD samples will be reviewed for method precision. The results will be evaluated against the laboratory's acceptance limits for the specified analytes and appropriate corrective action taken if warranted.

Laboratory personnel will be alerted that corrective actions are necessary if any of the following occur:

- The QC data is outside the warning or acceptance limits for precision and accuracy established for LCS. The laboratory QA Manager will consult the Project Chemist or the QA Officer to discuss out-of-control data sets.
- Blanks contain contaminants at concentrations above the detection limit.
- Undesirable trends are detected in the LCS or MS percent recoveries, RPDs, or surrogate recoveries.
- Unusual changes in detection limits are observed.
- The laboratory QA Manager detects deficiencies during internal or external audits, or from the results of performance evaluation samples.

If the analyst identifies any nonconformity in the analytical methodologies or QC sample results, the laboratory will implement corrective actions immediately. Specific corrective actions are outlined in each laboratory QAM.

The analyst will review the preparation or extraction procedures for possible errors, check the instrument calibration, evaluate spike and calibration mixes, check instrument sensitivity, and will initially handle corrective action procedures at the bench level. The analyst will immediately notify his/her supervisor of the identified problem and the investigation that is being conducted. If the problem persists or cannot be identified, the matter will be referred to the laboratory supervisor and laboratory QA Manager, and if the data are impacted, the Project Chemist and QA Officer will be provided a corrective action memo for inclusion in the project file.

Corrective action may include, but will not be limited to, the following:

- Reanalyzing suspect samples if holding time criteria permit;
- Retrieving the archived sample for analysis;
- Accepting data with acknowledged level of uncertainty (with consultation);
- Recalibrating analytical instruments;
- Evaluating and attempting to identify data limitations; and
- Resampling.

7.2.3 Corrective Actions Following Data Evaluation

Working with the Project Chemist, the QA Officer will be responsible for reviewing the laboratory data generated for this project and ensuring that all project QA objectives are met. If any nonconformances are found in field procedures, sample collection procedures, field documentation procedures, laboratory analytical and documentation procedures, and data evaluation and quality review procedures, the impact of those nonconformances on the overall project QA objectives will be assessed. Appropriate actions, including reanalysis or resampling, will be recommended to the TEC INC. Project Manager so that the project objectives can be accomplished. Data deemed unacceptable by the TEC INC. Project Manager, following the implementation of the

required corrective action measures, will not be accepted and further follow-up corrective actions will be explored.

7.3 Reports

A Data Verification, Validation, and Evaluation Report will be prepared at the end of data collection activities for this project. This report will include discussion of data quality as determined during the data verification, data quality review, and assessment process described in Section 8 of this QAPP.

8.0 DATA REVIEW, VERIFICATION, VALIDATION, AND ASSESSMENT

8.1 Data Review

All analytical data may be reviewed by the Project QA Manager, Project Chemist, Field Manager, Hydrogeologist, or Risk Assessor as part of the process of preparing the information for use in the risk assessment.

8.2 Validation and Data Quality Review of Project Analytical Data

Full data validation will be performed on 10% of all analyses. Data from all other analyses will undergo a data quality review. Validation and data quality review will be performed according to the current USEPA functional guidelines for organic and inorganic data review, the USEPA Office of Solid Waste and Emergency Response (OSWER) standard operating procedures (SOPs) for inorganic and organic data review, SW-846 Method requirements, and project-specific requirements specified in this QAPP. Results of the data validation and data quality review will be presented in the Data Validation Report.

8.2.1 Data Quality Review

Data quality review involves a comprehensive check of the laboratory's certified analytical report (CAR) to assess the following: chain of custody (COC) compliance; holding time compliance; presence or absence of laboratory contamination as demonstrated by method and field blanks; accuracy and bias as demonstrated by recovery of surrogate spikes, laboratory control samples, and matrix spikes; analytical precision as

the relative percent difference (RPD) of analyte concentration between replicate samples (i.e., laboratory duplicates); sampling precision as the RPD of analyte concentration between field duplicates; calibration performance; and degree of conformance to method requirements and good laboratory practices. Data quality review does not include a review of the raw analytical data.

8.2.2 Data Validation

Data validation is performed similarly to a data quality review, but it is a comprehensive evaluation of laboratory data by experienced analytical chemists. It involves complete review of all raw data associated with the project samples in a process that includes reconstruction and verification of initial calibrations, and recalculation of sample results from instrument printouts and sample preparation bench sheets.

8.3 Data Validation Report

The Data Validation Report will summarize the performance of the project team in meeting the QA criteria outlined in this QAPP. The Data Validation Report will include, but is not limited to:

- Compliance with this QAPP,
- Chain-of-custody documentation,
- Compliance with technical holding times,
- Instrument calibration,
- Compliance with project-specific reporting limits,
- Field and laboratory QC samples (precision and accuracy),
- Field and method blanks, and
- Discussion of limitations on data usability.

8.4 Final Data Quality Assessment

A final data quality assessment will be performed by the Project Risk Assessor as part of preparing the data for use in the risk assessment or constituent fate and transport

modeling process. Any data usability issues identified by the Project Risk Assessor or Hydrogeologist will be communicated to the Project Chemist or Project Field Manager for further investigation and corrective action.

Table 1-1
Summary of Analytical Methods
Red Hill Bulk Fuel Storage Facility
Pearl Harbor, Hawaii

ANALYSIS	METHOD	SOIL GAS MATRIX SAMPLES	ROCK/SOIL MATRIX SAMPLES	WATER MATRIX SAMPLES
VOCs by GC/MS	TO-15	11	-	-
Pulverizing	ASTM	-	9	NA
Volatile TPH (GRO)	SW846 8015B	-	9	6
Semi-Volatile TPH (DRO)	SW846 8015B	-	9	6
Extractable Total Petroleum Hydrocarbon	MADEP EPH	-	9	6
Volatile Total Petroleum Hydrocarbon	MADEP VPH	-	9	6
VOCs	SW846 8260B	-	9	6
Polynuclear Aromatic Hydrocarbons	SW846 8270C	-	9	6
Lead	SW846 6010B	-	9	6
Lead, Tetraethyl	ASTM D3341 87M	-	9	6
Lead, Dissolved (lab to filter)	SW846 6010B	-	NA	6
Alkalinty	E310.1	-	-	6
Nitrate	E300	-	-	6
Sulfate	E300	-	-	6
Methane	RSK-175	-	-	6
Ferrous iron	Colorometric (field)	-	-	6
Dissolved Oxygen	Field Meter	-	-	6

Notes:

DRO = diesel range organics
GRO = gasoline range organics
TPH = total petroleum hydrocarbons
VOCs = volatile organic compounds

Table 2-1
Laboratory Methods Limits of Detection (LOD) and Reporting Limits (RLs)

LABORATORY METHODS Limits of detection (LOD) AND RLs					
Parameter	Method	Matrix	Units	desired LOD	estimated RL/EQL
Metals - ICP					
Lead (total and dissolved)	6010B	W	mg/L	0.00234	0.010
Lead	6010B	S	mg/kg	0.23	0.50
Metals -ASTM D3341 91					
Lead, Tetraethyl	D3341	W	mg/L	0.00100	0.010
Lead Tetraethyl	D3341	S	mg/kg	0.10	1.00
Volatiles - GC/MS					
Acetone	8260B	W	ug/L	3.02	10
Benzene	8260B	W	ug/L	0.25	0.5
Bromobenzene	8260B	W	ug/L	0.18	1
Bromochloromethane	8260B	W	ug/L	0.27	1
Bromodichloromethane	8260B	W	ug/L	0.09	1
Bromoform (tribromomethane)	8260B	W	ug/L	0.23	1
Bromomethane (Methyl bromide)	8260B	W	ug/L	0.78	1
2-Butanone	8260B	W	ug/L	3.50	10
n-Butylbenzene	8260B	W	ug/L	0.32	1
sec-Butylbenzene	8260B	W	ug/L	0.33	1
tert-Butylbenzene	8260B	W	ug/L	0.16	1
Carbon Disulfide	8260B	W	ug/L	0.54	10
Carbon Tetrachloride	8260B	W	ug/L	0.11	0.5
Chlorobenzene	8260B	W	ug/L	0.20	1
Chloroethane	8260B	W	ug/L	0.50	1
Chloroform	8260B	W	ug/L	0.16	1
Chloromethane	8260B	W	ug/L	0.43	1
2-Chlorotoluene	8260B	W	ug/L	0.26	1
4-Chlorotoluene	8260B	W	ug/L	0.22	1
Dibromochloromethane	8260B	W	ug/L	0.24	1
1,2-Dibromo-3-Chloropropane	8260B	W	ug/L	2.84	5
1,2-Dibromoethane	8260B	W	ug/L	0.15	1
Dibromomethane	8260B	W	ug/L	0.22	1
1,2-Dichlorobenzene	8260B	W	ug/L	0.22	1
1,3-Dichlorobenzene	8260B	W	ug/L	0.33	1
1,4-Dichlorobenzene	8260B	W	ug/L	0.36	1
Dichlorodifluoromethane	8260B	W	ug/L	0.34	1
1,1-Dichloroethane	8260B	W	ug/L	0.27	1
1,2-Dichloroethane	8260B	W	ug/L	0.37	0.5
1,1-Dichloroethene	8260B	W	ug/L	0.25	1
c-1,2-Dichloroethene	8260B	W	ug/L	0.43	1
t-1,2-Dichloroethene	8260B	W	ug/L	0.33	1
1,2-Dichloropropane	8260B	W	ug/L	0.36	1
1,3-Dichloropropane	8260B	W	ug/L	0.17	1
2,2-Dichloropropane	8260B	W	ug/L	0.38	1
1,1-Dichloropropene	8260B	W	ug/L	0.24	1
c-1,3-Dichloropropene	8260B	W	ug/L	0.20	0.5
t-1,3-Dichloropropene	8260B	W	ug/L	0.17	0.5
Ethylbenzene	8260B	W	ug/L	0.17	1
2-Hexanone	8260B	W	ug/L	2.97	10
Isopropylbenzene	8260B	W	ug/L	0.16	1
p-Isopropyltoluene	8260B	W	ug/L	0.44	1
Methylene Chloride	8260B	W	ug/L	2.90	10
4-Methyl-2-Pentanone	8260B	W	ug/L	2.92	10
Naphthalene	8260B	W	ug/L	0.57	10
n-Propylbenzene	8260B	W	ug/L	0.25	1
Styrene	8260B	W	ug/L	0.23	1
1,1,1,2-Tetrachloroethane	8260B	W	ug/L	0.13	1
1,1,2,2-Tetrachloroethane	8260B	W	ug/L	0.29	1
Tetrachloroethene	8260B	W	ug/L	0.37	1
Toluene	8260B	W	ug/L	0.11	1
1,2,3-Trichlorobenzene	8260B	W	ug/L	0.47	1
1,2,4-Trichlorobenzene	8260B	W	ug/L	0.37	1
1,1,1-Trichloroethane	8260B	W	ug/L	0.18	1
1,1,2-Trichloroethane	8260B	W	ug/L	0.22	1
Trichloroethene	8260B	W	ug/L	0.24	1
Trichlorofluoromethane	8260B	W	ug/L	0.35	10
1,2,3-Trichloropropane	8260B	W	ug/L	0.33	1
1,2,4-Trimethylbenzene	8260B	W	ug/L	0.21	1
1,3,5-Trimethylbenzene	8260B	W	ug/L	0.25	1
Vinyl Acetate	8260B	W	ug/L	1.84	10
Vinyl Chloride	8260B	W	ug/L	0.26	0.5
p/m-Xylene	8260B	W	ug/L	0.30	1
o-Xylene	8260B	W	ug/L	0.14	1
Methyl-tert-Butyl Ether	8260B	W	ug/L	0.20	1

Table 2-1
Laboratory Methods Limits of Detection (LOD) and Reporting Limits (RLs)

LABORATORY METHODS Limits of detection (LOD) AND RLs					
Parameter	Method	Matrix	Units	desired LOD	estimated RL/EQL
Acetone	8260B	S	ug/kg	11.1	50
Benzene	8260B	S	ug/kg	0.62	5
Bromobenzene	8260B	S	ug/kg	0.78	5
Bromochloromethane	8260B	S	ug/kg	1.23	5
Bromodichloromethane	8260B	S	ug/kg	1.54	5
Bromoform	8260B	S	ug/kg	1.64	5
Bromomethane (Methyl bromide)	8260B	S	ug/kg	3.34	5
2-Butanone	8260B	S	ug/kg	11.22	50
n-Butylbenzene	8260B	S	ug/kg	1.14	5
sec-Butylbenzene	8260B	S	ug/kg	1.16	5
tert-Butylbenzene	8260B	S	ug/kg	1.79	5
Carbon Disulfide	8260B	S	ug/kg	1.46	50
Carbon Tetrachloride	8260B	S	ug/kg	1.43	5
Chlorobenzene	8260B	S	ug/kg	1.33	5
Chloroethane	8260B	S	ug/kg	2.60	5
Chloroform	8260B	S	ug/kg	1.48	5
Chloromethane	8260B	S	ug/kg	2.67	5
2-Chlorotoluene	8260B	S	ug/kg	1.26	5
4-Chlorotoluene	8260B	S	ug/kg	1.20	5
Dibromochloromethane	8260B	S	ug/kg	1.73	5
1,2-Dibromo-3-Chloropropane	8260B	S	ug/kg	5.28	10
1,2-Dibromoethane	8260B	S	ug/kg	1.35	5
Dibromomethane	8260B	S	ug/kg	1.54	5
1,2-Dichlorobenzene	8260B	S	ug/kg	1.39	5
1,3-Dichlorobenzene	8260B	S	ug/kg	1.12	5
1,4-Dichlorobenzene	8260B	S	ug/kg	1.20	5
Dichlorodifluoromethane	8260B	S	ug/kg	1.99	5
1,1-Dichloroethane	8260B	S	ug/kg	1.25	5
1,2-Dichloroethane (EDC)	8260B	S	ug/kg	1.76	5
1,1-Dichloroethene	8260B	S	ug/kg	1.58	5
c-1,2-Dichloroethene	8260B	S	ug/kg	2.61	5
t-1,2-Dichloroethene	8260B	S	ug/kg	0.84	5
1,2-Dichloropropane	8260B	S	ug/kg	2.49	5
1,3-Dichloropropane	8260B	S	ug/kg	1.19	5
2,2-Dichloropropane	8260B	S	ug/kg	1.99	5
1,1-Dichloropropene	8260B	S	ug/kg	1.47	5
c-1,3-Dichloropropene	8260B	S	ug/kg	0.87	5
t-1,3-Dichloropropene	8260B	S	ug/kg	1.12	5
Ethylbenzene	8260B	S	ug/kg	1.00	5
2-Hexanone	8260B	S	ug/kg	4.42	50
Isopropylbenzene	8260B	S	ug/kg	1.04	5
p-Isopropyltoluene	8260B	S	ug/kg	1.26	5
Methylene Chloride	8260B	S	ug/kg	2.78	50
4-Methyl-2-Pentanone	8260B	S	ug/kg	4.4	50
Naphthalene	8260B	S	ug/kg	2.6	50
n-Propylbenzene	8260B	S	ug/kg	1.17	5
Styrene	8260B	S	ug/kg	1.09	5
1,1,1,2-Tetrachloroethane	8260B	S	ug/kg	1.66	5
1,1,2,2-Tetrachloroethane	8260B	S	ug/kg	1.81	5
Tetrachloroethene	8260B	S	ug/kg	1.23	5
Toluene	8260B	S	ug/kg	0.43	5
1,2,3-Trichlorobenzene	8260B	S	ug/kg	2.47	10
1,2,4-Trichlorobenzene	8260B	S	ug/kg	3.86	5
1,1,1-Trichloroethane	8260B	S	ug/kg	1.26	5
1,1,2-Trichloroethane	8260B	S	ug/kg	2.08	5
Trichloroethene	8260B	S	ug/kg	1.52	5
Trichlorofluoromethane	8260B	S	ug/kg	2.09	50
1,2,3-Trichloropropane	8260B	S	ug/kg	2.76	5
1,2,4-Trimethylbenzene	8260B	S	ug/kg	1.20	5
1,3,5-Trimethylbenzene	8260B	S	ug/kg	1.12	5
Vinyl Acetate	8260B	S	ug/kg	2.45	50
Vinyl Chloride	8260B	S	ug/kg	0.98	5
p/m-Xylene	8260B	S	ug/kg	0.87	5
o-Xylene	8260B	S	ug/kg	1.21	5
Methyl-tert-Butyl Ether	8260B	S	ug/kg	1.70	5

Table 2-1
Laboratory Methods Limits of Detection (LOD) and Reporting Limits (RLs)

LABORATORY METHODS Limits of detection (LOD) AND RLs					
Parameter	Method	Matrix	Units	desired LOD	estimated RL/EQL
Semi-Volatiles - GCMS					
Naphthalene	8270C	W	ug/L	1.79	10
Acenaphthylene	8270C	W	ug/L	0.86	10
Acenaphthene	8270C	W	ug/L	0.94	10
Anthracene	8270C	W	ug/L	1.15	10
Fluorene	8270C	W	ug/L	1.08	10
Fluoranthene	8270C	W	ug/L	1.07	10
Pyrene	8270C	W	ug/L	1.00	10
Benzo (a) Anthracene	8270C	W	ug/L	0.86	10
Chrysene	8270C	W	ug/L	1.03	10
Benzo (b) Fluoranthene	8270C	W	ug/L	0.75	10
Benzo (k) Fluoranthene	8270C	W	ug/L	1.11	10
Benzo (a) Pyrene	8270C	W	ug/L	0.72	10
Benzo (g,h,i) Perylene	8270C	W	ug/L	0.88	10
Indeno (1,2,3-c,d) Pyrene	8270C	W	ug/L	0.79	10
Dibenz (a,h) Anthracene	8270C	W	ug/L	0.98	10
<hr/>					
Naphthalene	8270C	S	mg/kg	0.0920	0.8
Acenaphthylene	8270C	S	mg/kg	0.0985	0.8
Acenaphthene	8270C	S	mg/kg	0.1105	0.8
Fluorene	8270C	S	mg/kg	0.1005	0.8
Phenanthrene	8270C	S	mg/kg	0.1031	0.8
Anthracene	8270C	S	mg/kg	0.1194	0.8
Fluoranthene	8270C	S	mg/kg	0.1098	0.8
Pyrene	8270C	S	mg/kg	0.1307	0.8
Benzo (a) Anthracene	8270C	S	mg/kg	0.1025	0.8
Chrysene	8270C	S	mg/kg	0.0940	0.8
Benzo (b) Fluoranthene	8270C	S	mg/kg	0.0973	0.8
Benzo (k) Fluoranthene	8270C	S	mg/kg	0.1145	0.8
Benzo (a) Pyrene	8270C	S	mg/kg	0.1028	0.7
Indeno (1,2,3-c,d) Pyrene	8270C	S	mg/kg	0.1023	0.8
Dibenz (a,h) Anthracene	8270C	S	mg/kg	0.1074	0.8
Benzo (g,h,i) Perylene	8270C	S	mg/kg	0.1087	0.8
<hr/>					
Total Petroleum Hydrocarbons (TPH) - GC					
TPH as gasoline	8015M	W	ug/L	51.1	500
TPH as diesel	8015M	W	ug/L	863	1000
<hr/>					
TPH as gasoline	8015M	S	mg/kg	0.126	0.5
TPH as diesel	8015M	S	mg/kg	4.81	5
<hr/>					
Extractable and Volatile Total Petroleum Hydrocarbons (TPH)					
Extractable TPH, all ranges	MADEP EPH	W	ug/L	200.0	1000
Volatile TPH, all ranges	MADEP VPH	W	ug/L	10	100
<hr/>					
Extractable TPH, all ranges	MADEP EPH	S	mg/kg	20	100
Volatile TPH, all ranges	MADEP VPH	S	mg/kg	0.5	5
<hr/>					
Gases					
Methane	RSK-175	W	mg/L	0.127	1
<hr/>					
Anions - IC					
Nitrate	300.0	W	mg/L	0.030	0.1
Sulfate	300.0	W	mg/L	0.110	1
<hr/>					
General Chemistry					
Alkalinity	310.1	W	mg/L	0.200	1
<hr/>					
Field Tests- Chemistry					
Ferrous Iron	SM3500	W	mg/L	0.2	0.05
Dissolved Oxygen	360.1	W	mg/L	1	0.05
<hr/>					
Volatiles - GC/MS					
Dichlorodifluoromethane	TO-15	A	uL/L	0.16	0.5
Chloromethane	TO-15	A	uL/L	0.13	0.5
Chloroform	TO-15	A	uL/L	0.17	0.5
Vinyl Chloride	TO-15	A	uL/L	0.16	0.5
Bromomethane	TO-15	A	uL/L	0.38	0.5
Chloroethane	TO-15	A	uL/L	0.19	0.5
Trichlorofluoromethane	TO-15	A	uL/L	0.18	0.5
1,1-Dichloroethene	TO-15	A	uL/L	0.13	0.5
Methylene Chloride	TO-15	A	uL/L	0.14	2
Tetrachloroethene	TO-15	A	uL/L	0.16	0.5
1,1,2-Dichloro-1,2,2-Trifluoroethane	TO-15	A	uL/L	0.18	1
1,1-Dichloroethane	TO-15	A	uL/L	0.16	0.5
1,2-Dichloro-1,1,2,2-Tetrafluoroethane	TO-15	A	uL/L	0.14	2
c-1,2-Dichloroethene	TO-15	A	uL/L	0.19	0.5
1,2-Dichloroethane	TO-15	A	uL/L	0.17	0.5
1,1,1-Trichloroethane	TO-15	A	uL/L	0.17	0.5

Table 2-1
Laboratory Methods Limits of Detection (LOD) and Reporting Limits (RLs)

LABORATORY METHODS Limits of detection (LOD) AND RLs					
Parameter	Method	Matrix	Units	desired LOD	estimated RL/EQL
Benzene	TO-15	A	uL/L	0.15	0.5
Carbon Tetrachloride	TO-15	A	uL/L	0.14	0.5
1,2-Dichloropropane	TO-15	A	uL/L	0.14	0.5
Trichloroethene	TO-15	A	uL/L	0.14	0.5
c-1,3-Dichloropropene	TO-15	A	uL/L	0.16	0.5
t-1,3-Dichloropropene	TO-15	A	uL/L	0.15	0.5
1,2,2-Trichloroethane	TO-15	A	uL/L	0.15	0.5
Toluene	TO-15	A	uL/L	0.17	0.5
Chlorobenzene	TO-15	A	uL/L	0.2	0.5
1,2-Dichlorobenzene	TO-15	A	uL/L	0.2	0.5
Ethylbenzene	TO-15	A	uL/L	0.16	0.5
p/m-Xylenes	TO-15	A	uL/L	0.42	1
Styrene	TO-15	A	uL/L	0.16	1
1,1,2,2-Tetrachloroethane	TO-15	A	uL/L	0.19	0.5
o-Xylene	TO-15	A	uL/L	0.16	0.5
1,3,5-Trimethylbenzene	TO-15	A	uL/L	0.16	0.5
1,2,4-Trimethylbenzene	TO-15	A	uL/L	0.18	0.5
Benzyl Chloride	TO-15	A	uL/L	0.18	0.5
1,3-Dichlorobenzene	TO-15	A	uL/L	0.19	0.5
1,4-Dichlorobenzene	TO-15	A	uL/L	0.18	0.5
1,2-Dibromoethane	TO-15	A	uL/L	0.18	0.5
1,2,4-Trichlorobenzene	TO-15	A	uL/L	0.21	0.5
Hexachloro-1,3-Butadiene	TO-15	A	uL/L	0.18	0.5
Acetonitrile	TO-15	A	uL/L	0.22	1
t-1,2-Dichloroethene	TO-15	A	uL/L	0.18	0.5
2-Butanone	TO-15	A	uL/L	0.15	1
Dibromochloromethane	TO-15	A	uL/L	0.17	0.5
Bromodichloromethane	TO-15	A	uL/L	0.17	0.5
Acetone	TO-15	A	uL/L	0.18	1
Methyl-t-Butyl Ether	TO-15	A	uL/L	0.18	2
4-Methyl-2-Pentanone	TO-15	A	uL/L	0.22	1
Bromoform	TO-15	A	uL/L	0.23	0.5
Carbon Disulfide	TO-15	A	uL/L	0.15	0.5
Vinyl Acetate	TO-15	A	uL/L	0.17	1
2-Hexanone	TO-15	A	uL/L	0.21	1
4-Ethyltoluene	TO-15	A	uL/L	0.18	0.5

TABLE 2-2
Sensitivity Goals
Red Hill Bulk Storage Facility

Method	Analyte	Groundwater (mg/L)	Solid (mg/Kg)
SW-8468260B ¹	Benzene	0.005	0.05
	Toluene	1.0	16
	Ethylbenzene	0.14	0.50
	Xylene	10	23
	MTBE	0.02	0.05
SW-846 8310 or SW-846 8270SIM ¹	Benzo(a)pyrene	0.0002	1.0
	Acenaphthene	0.32	18
	Fluoranthene	0.013	11
	Naphthalene	0.24	41
SW-846 6010B ¹	Lead (total)	0.0056	400
SW-846 8015 ¹	Gasoline-range organics	NS	5000
	Diesel-range organics	NS	2000
MADEP VPH ²	C ₅ -C ₈ aliphatics	0.010	5.0
	C ₈ -C ₁₂ aliphatics	0.010	5.0
	C ₉ -C ₁₀ aromatics	0.010	5.0
	Total TPH	0.010	5.0
MADEP EPH ³	C ₉ -C ₁₈ aliphatics	0.010	20
	C ₁₉ -C ₃₆ aliphatics	0.010	20
	C ₁₁ -C ₂₂ aromatics	0.010	20
	Total TPH	0.010	20
ASTM D3341 ⁴	Tetraethyl lead	0.010	2.0

NS No standard.

¹ Hawaii Administrative Rules, Underground Storage Tanks, Department of Health, Title 11, Chapter 281, and MTBE DOH UST Policy Update dated Oct 16, 1998

² MADEP, Final Method for the Determination of Extractable Petroleum Hydrocarbons, May 2004.

³ MADEP, Final Method for the Determination of Volatile Petroleum Hydrocarbons, May 2004.

⁴ ASTM D3311, Standard Method for Lead in Gasoline- Iodine Monochlorine Method, ASTM International.

TABLE 4-1
Sample Containers, Preservatives, and Holding Times
Red Hill Bulk Storage Facility

Analysis	Method	Container ¹	Preservative	Holding Time
Solid				
GRO	8015B	4 or 9 oz Glass Jar ²	Cool to 4°C	14 days
VPH	MADEP VPH	4 or 9 oz Glass Jar ²	Cool to 4°C	14 days
DRO	8015B	4 or 9 oz Glass Jar ²	Cool to 4°C	14/40 days ³
EPH	MADEP EPH	4 or 9 oz Glass Jar ²	Cool to 4°C	14/40 days ³
BTEX/MTBE	8260B	4 or 9 oz Glass Jar ²	Cool to 4°C	14 days
PAH	8310 or 8270 SIM	4 or 9 oz Glass Jar ²	Cool to 4°C	14/40 days ³
Lead	6010B	4 or 9 oz Glass Jar ²	Cool to 4°C	6 months
Tetraethyl Lead	ASTM D3341	4 or 9 oz Glass Jar ²	Cool to 4°C	NS
Water Samples				
GRO	8015B	3 – 40 mL Glass Vials, no headspace	HCl to pH<2, cool to 4°C	14 Days
VPH	MADEP VPH	3 – 40 mL Glass Vials, no headspace	HCl to pH<2, cool to 4°C	14 Days
DRO	8015B	2 – 1 L Amber Glass Bottles	HCl to pH<2, cool to 4°C	14/40 days ³
EPH	MADEP EPH	2 – 1 L Amber Glass Bottles	HCl to pH<2, cool to 4°C	14/40 days ³
BTEX/MTBE	8260B	3 – 40 mL Glass Vials, no headspace	HCl to pH<2, cool to 4°C	14 Days
PAH	8310	2 – 1 L Amber Glass Bottles	Cool to 4°C	7/40 days ³
	8270 SIM	2 – 1 L Amber Glass Bottles		
Total Lead	6010B	1 – 250 or 500 mL HDPE	HNO ₃ to pH<2, cool to 4°C	6 months
Dissolved Lead		1 – 250 or 500 mL HDPE, field filtered		
Tetraethyl Lead	ASTM D3341	1 - 250 mL HDPE	Cool to 4°C	NS

BTEX Benzene, Toluene, Ethylbenzene, Xylenes
DRO Diesel-range organics
EPH Extractable petroleum hydrocarbons
GRO Gasoline-range organics
MTBE Methyl tert-butyl ether
NS Not specified
PAH Polynuclear aromatic hydrocarbons
VPH Volatile petroleum hydrocarbons

Notes:

- ¹ Double sample volume collected for MS/MSD.
- ² Multiple tests may be performed from the sample 4 or 9 oz. Jar, so a jar is not needed for each individual test.
- ³ Number of days from collection until extraction/number of days from time of extraction until analysis.

TABLE 5-1
Laboratory Quality Control Samples
Red Hill Bulk Storage Facility

Method	Method Blanks ¹	Duplicate Analyses ^{1,2}	MS ¹	LCS ¹ (Blank Spike)	Surrogate	Initial Calibration	Initial Calibration Verification	Continuing Calibration Standard
GRO	1/Batch	1/Batch	1/Batch	1/Batch	All Samples	5-point	1/curve	Every 10 samples
VPH	1/Batch	1/Batch	1/Batch	1/Batch	All Samples	5-point	1/curve	Every 10 samples
DRO	1/Batch	1/Batch	1/Batch	1/Batch	All Samples	5-point	1/curve	Every 10 samples
EPH	1/Batch	1/Batch	1/Batch	1/Batch	All Samples	5-point	1/curve	Every 10 samples
BTEX/MTBE	1/Batch	1/Batch	1/Batch	1/Batch	All Samples	5-point	1/curve	Every 12 hours
PAH	1/Batch	1/Batch	1/Batch	1/Batch	All Samples	5-point	1/curve	Every 12 hours
Lead	1/Batch	1/Batch	1/Batch	1/Batch	NA	Instrument Specific	1/curve	Every 10 samples
Tetraethyl Lead	1/Batch	1/Batch	1/Batch	1/Batch	NA	Instrument Specific	1/curve	Every 10 samples

¹ Batch is equivalent to 20, or fewer, samples prepared and analyzed together with common QC samples.

² Duplicate analyses might be laboratory duplicates, LCS/LCSD, and/or MS/MSD.

BTEX Benzene, Toluene, Ethylbenzene, Xylenes

DRO Diesel-range organics

EPH Extractable petroleum hydrocarbons

GRO Gasoline-range organics

LCS Laboratory control sample

MS Matrix spike

MTBE Methyl tert-butyl ether

NA Not Applicable

PAH Polynuclear aromatic hydrocarbons

VPH Volatile petroleum hydrocarbons

Appendix D
Hawaii Department of Health Quarterly Deliverables
(Examples)



Mann-Kendall Statistics Summary

Well: ST10MW02

Well Type: Monitoring

COPC: Naphthalene

Time Period: 5/1998 to 10/2006

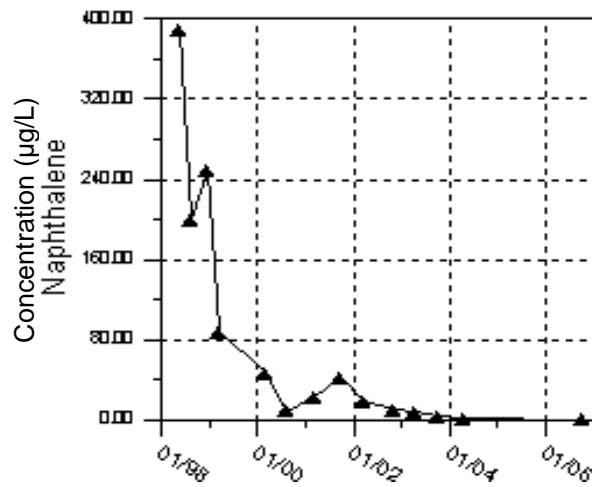

S = -79.00

n = 14

Var(S) = 333.6667

Z = 2701

Result =
Hypothesis of decreasing trend accepted

Mean = 77.6402

s = 118.568

CV = 1.5272

Assumption of normality is rejected

Data:

Sample Date	Naphthalene (µg/L)
5/1998	390.0
8/1998	200.0
12/1998	250.0
3/1999	87.0
3/2000	46.0
8/2000	8.9
3/2001	23.0
9/2001	42.0
3/2002	18.0
10/2002	10.0
4/2003	7.6
10/2003	3.66
4/2004	0.79
10/2006	0.013*

- qualifying flags have been removed from data

* denotes assigned value for samples with undetected analytes

Appendix E
 Database Format for Groundwater Monitoring Results
 Red Hill Quarterly Monitoring

Sample	Parameter	Analytical	Preparation	CAS	Result	Qual	Units	RL	MDL	Sample Typ	DF	Client ID	Collected	Time
F48353-1	TPH (C10-C28)	SW8015	SW3510C		0.098	U	mg/l	0.25	0.098	SAMP	1	RHMW225	27-Mar-07	09:15
F48353-1	o-Terphenyl	SW8015	SW3510C	84-15-1	89	U	%	0.49		SAMP	1	RHMW225	27-Mar-07	09:15
F48353-1	TPH-GRO (C6-C10)	SW8015			0.050	U	mg/l	0.10	0.050	SAMP	1	RHMW225	27-Mar-07	09:15
F48353-1	4-Bromofluorobenzene	SW8015		460-00-4	88	U	%			SAMP	1	RHMW225	27-Mar-07	09:15
F48353-1	aaa-Trifluorotoluene	SW8015		98-08-8	87	U	%			SAMP	1	RHMW225	27-Mar-07	09:15
F48353-1	Acenaphthene	SW8270C	SW3510C	83-32-9	0.49	U	ug/l	0.97	0.49	SAMP	1	RHMW225	27-Mar-07	09:15
F48353-1	Acenaphthylene	SW8270C	SW3510C	208-96-8	0.49	U	ug/l	0.97	0.49	SAMP	1	RHMW225	27-Mar-07	09:15
F48353-1	Anthracene	SW8270C	SW3510C	120-12-7	0.49	U	ug/l	0.97	0.49	SAMP	1	RHMW225	27-Mar-07	09:15
F48353-1	Benzo(a)anthracene	SW8270C	SW3510C	56-55-3	0.049	U	ug/l	0.19	0.049	SAMP	1	RHMW225	27-Mar-07	09:15
F48353-1	Benzo(a)pyrene	SW8270C	SW3510C	50-32-8	0.097	U	ug/l	0.19	0.097	SAMP	1	RHMW225	27-Mar-07	09:15
F48353-1	Benzo(b)fluoranthene	SW8270C	SW3510C	205-99-2	0.049	U	ug/l	0.19	0.049	SAMP	1	RHMW225	27-Mar-07	09:15
F48353-1	Benzo(g,h,i)perylene	SW8270C	SW3510C	191-24-2	0.097	U	ug/l	0.19	0.097	SAMP	1	RHMW225	27-Mar-07	09:15
F48353-1	Benzo(k)fluoranthene	SW8270C	SW3510C	207-08-9	0.097	U	ug/l	0.19	0.097	SAMP	1	RHMW225	27-Mar-07	09:15
F48353-1	Chrysene	SW8270C	SW3510C	218-01-9	0.097	U	ug/l	0.19	0.097	SAMP	1	RHMW225	27-Mar-07	09:15
F48353-1	Dibenzo(a,h)anthracene	SW8270C	SW3510C	53-70-3	0.049	U	ug/l	0.19	0.049	SAMP	1	RHMW225	27-Mar-07	09:15
F48353-1	Fluoranthene	SW8270C	SW3510C	206-44-0	0.24	U	ug/l	0.97	0.24	SAMP	1	RHMW225	27-Mar-07	09:15
F48353-1	Fluorene	SW8270C	SW3510C	86-73-7	0.24	U	ug/l	0.97	0.24	SAMP	1	RHMW225	27-Mar-07	09:15
F48353-1	Indeno(1,2,3-cd)pyrene	SW8270C	SW3510C	193-39-5	0.049	U	ug/l	0.19	0.049	SAMP	1	RHMW225	27-Mar-07	09:15
F48353-1	1-Methylnaphthalene	SW8270C	SW3510C	90-12-0	0.24	U	ug/l	0.97	0.24	SAMP	1	RHMW225	27-Mar-07	09:15
F48353-1	2-Methylnaphthalene	SW8270C	SW3510C	91-57-6	0.24	U	ug/l	0.97	0.24	SAMP	1	RHMW225	27-Mar-07	09:15
F48353-1	Naphthalene	SW8270C	SW3510C	91-20-3	0.24	U	ug/l	0.97	0.24	SAMP	1	RHMW225	27-Mar-07	09:15
F48353-1	Phenanthrene	SW8270C	SW3510C	85-01-8	0.49	U	ug/l	0.97	0.49	SAMP	1	RHMW225	27-Mar-07	09:15
F48353-1	Pyrene	SW8270C	SW3510C	129-00-0	0.24	U	ug/l	0.97	0.24	SAMP	1	RHMW225	27-Mar-07	09:15
F48353-1	Nitrobenzene-d5	SW8270C	SW3510C	4165-60-0	67	U	%			SAMP	1	RHMW225	27-Mar-07	09:15
F48353-1	2-Fluorobiphenyl	SW8270C	SW3510C	321-60-8	58	U	%			SAMP	1	RHMW225	27-Mar-07	09:15
F48353-1	Terphenyl-d14	SW8270C	SW3510C	1718-51-0	69	U	%			SAMP	1	RHMW225	27-Mar-07	09:15
F48353-1	Acetone	SW8260B	SW5030B	67-64-1	5.0	U	ug/l	25	5.0	SAMP	1	RHMW225	27-Mar-07	09:15
F48353-1	Acrolein	SW8260B	SW5030B	107-02-8	10	U	ug/l	20	10	SAMP	1	RHMW225	27-Mar-07	09:15
F48353-1	Acrylonitrile	SW8260B	SW5030B	107-13-1	5.0	U	ug/l	10	5.0	SAMP	1	RHMW225	27-Mar-07	09:15
F48353-1	Benzene	SW8260B	SW5030B	71-43-2	0.50	U	ug/l	1.0	0.50	SAMP	1	RHMW225	27-Mar-07	09:15
F48353-1	Bromobenzene	SW8260B	SW5030B	108-86-1	0.50	U	ug/l	1.0	0.50	SAMP	1	RHMW225	27-Mar-07	09:15
F48353-1	Bromochloromethane	SW8260B	SW5030B	74-97-5	0.50	U	ug/l	1.0	0.50	SAMP	1	RHMW225	27-Mar-07	09:15
F48353-1	Bromodichloromethane	SW8260B	SW5030B	75-27-4	0.50	U	ug/l	1.0	0.50	SAMP	1	RHMW225	27-Mar-07	09:15
F48353-1	Bromoform	SW8260B	SW5030B	75-25-2	0.50	U	ug/l	1.0	0.50	SAMP	1	RHMW225	27-Mar-07	09:15
F48353-1	n-Butylbenzene	SW8260B	SW5030B	104-51-8	0.50	U	ug/l	1.0	0.50	SAMP	1	RHMW225	27-Mar-07	09:15
F48353-1	sec-Butylbenzene	SW8260B	SW5030B	135-98-8	0.50	U	ug/l	1.0	0.50	SAMP	1	RHMW225	27-Mar-07	09:15
F48353-1	tert-Butylbenzene	SW8260B	SW5030B	98-06-6	0.50	U	ug/l	1.0	0.50	SAMP	1	RHMW225	27-Mar-07	09:15

Table 1. Analytical Results for Quarterly Groundwater Sampling Release Response Report, March 27, 2007
Red Hill Fuel Storage Facility, Hawaii

Method	Chemical	HDOH Residential Drinking Water EALs ¹ UG/L	HDOH Drinking Water Ceiling EALs ² UG/L	RHMW01 UG/L March 27, 2007				RHMW02 UG/L March 27, 2007				RHMW02D- UG/L March 27, 2007				RHMW03 UG/L March 27, 2007				RHMW2254-01 UG/L March 27, 2007			
				Result	Q	MDL	RL	Result	Q	MDL	RL	Result	Q	MDL	RL	Result	Q	MDL	RL	Result	Q	MDL	RL
SW8015V	TPH as GASOLINE RANGE ORGANICS	100	100	ND	U	50	100	122	0	50	100	148	0	50	100	ND	U	50	100	ND	U	50	100
SW8015E	PETROLEUM HYDROCARBONS ABOVE C-10	100	100	307	0	98	250	2750	0	97	240	2250	0	190	490	95.7	J	95	240	ND	U	98	250
SW8260B	1,1,1,2-TETRACHLOROETHANE	0.43	50000	ND	U	0.5	1	ND	U	0.5	1	ND	U	0.5	1	ND	U	0.5	1	ND	U	0.5	1
	1,1,1-TRICHLOROETHANE	200	970	ND	U	0.5	1	ND	U	0.5	1	ND	U	0.5	1	ND	U	0.5	1	ND	U	0.5	1
	1,1,2,2-TETRACHLOROETHANE	0.056	500	ND	U	0.4	1	ND	U	0.4	1	ND	U	0.4	1	ND	U	0.4	1	ND	U	0.4	1
	1,1,2-TRICHLOROETHANE	5	50000	ND	U	0.5	1	ND	U	0.5	1	ND	U	0.5	1	ND	U	0.5	1	ND	U	0.5	1
	1,2,4-TRICHLOROBENZENE	70	3000	ND	U	0.5	1	ND	U	0.5	1	ND	U	0.5	1	ND	U	0.5	1	ND	U	0.5	1
	1,2-DIBROMO-3-CHLOROPROPANE (DBCP)	0.04	10	ND	U	1	2	ND	U	1	2	ND	U	1	2	ND	U	1	2	ND	U	1	2
	1,2-DICHLOROPROPANE	5	10	ND	U	0.5	1	ND	U	0.5	1	ND	U	0.5	1	ND	U	0.5	1	ND	U	0.5	1
	1,3-DICHLOROBENZENE	180	50000	ND	U	0.5	1	ND	U	0.5	1	ND	U	0.5	1	ND	U	0.5	1	ND	U	0.5	1
	1,3-DICHLOROPROPANE	0.4	50000	ND	U	0.5	1	ND	U	0.5	1	ND	U	0.5	1	ND	U	0.5	1	ND	U	0.5	1
	1,4-DICHLOROBENZENE	75	5	ND	U	0.5	1	ND	U	0.5	1	ND	U	0.5	1	ND	U	0.5	1	ND	U	0.5	1
	ACETONE	5500	20000	ND	U	5	25	ND	U	5	25	ND	U	5	25	ND	U	5	25	ND	U	5	25
	BENZENE	5	170	ND	U	0.5	1	ND	U	0.5	1	ND	U	0.5	1	ND	U	0.5	1	ND	U	0.5	1
	BROMODICHLOROMETHANE	0.18	50000	ND	U	0.5	1	ND	U	0.5	1	ND	U	0.5	1	ND	U	0.5	1	ND	U	0.5	1
	BROMOFORM	100	510	ND	U	0.5	1	ND	U	0.5	1	ND	U	0.5	1	ND	U	0.5	1	ND	U	0.5	1
	BROMOMETHANE	8.5	50000	ND	U	1	2	ND	U	1	2	ND	U	1	2	ND	U	1	2	ND	U	1	2
	CARBON TETRACHLORIDE	5	520	ND	U	0.5	1	ND	U	0.5	1	ND	U	0.5	1	ND	U	0.5	1	ND	U	0.5	1
	CHLOROBENZENE	100	50	ND	U	0.5	1	ND	U	0.5	1	ND	U	0.5	1	ND	U	0.5	1	ND	U	0.5	1
	CHLOROETHANE	3.9	16	ND	U	1	2	ND	U	1	2	ND	U	1	2	ND	U	1	2	ND	U	1	2
	CHLOROFORM	100	2400	ND	U	0.5	1	ND	U	0.5	1	ND	U	0.5	1	ND	U	0.5	1	ND	U	0.5	1
	CHLOROMETHANE	160	50000	ND	U	1	2	ND	U	1	2	ND	U	1	2	ND	U	1	2	ND	U	1	2
	cis-1,2-DICHLOROETHYLENE	70	50000	ND	U	0.5	1	ND	U	0.5	1	ND	U	0.5	1	ND	U	0.5	1	ND	U	0.5	1
	DIBROMOMETHANE	0.0056	50000	ND	U	0.5	2	ND	U	0.5	2	ND	U	0.5	2	ND	U	0.5	2	ND	U	0.5	2
	ETHYLBENZENE	700	30	ND	U	0.5	1	ND	U	0.5	1	ND	U	0.5	1	ND	U	0.5	1	ND	U	0.5	1
	HEXACHLOROBUTADIENE	0.86	6	ND	U	0.5	2	ND	U	0.5	2	ND	U	0.5	2	ND	U	0.5	2	ND	U	0.5	2
	M,P-XYLENE (SUM OF ISOMERS)	10000	20	ND	U	0.5	2	ND	U	0.5	2	ND	U	0.5	2	ND	U	0.5	2	ND	U	0.5	2
	METHYL ETHYL KETONE (2-BUTANONE)	7000	8400	ND	U	2.5	5	ND	U	2.5	5	ND	U	2.5	5	ND	U	2.5	5	ND	U	2.5	5
	METHYL ISOBUTYL KETONE (4-METHYL-2-PENTANONE)	2000	1300	ND	U	2.5	5	ND	U	2.5	5	ND	U	2.5	5	ND	U	2.5	5	ND	U	2.5	5
	METHYLENE CHLORIDE	4.3	9100	ND	U	1	5	ND	U	1	5	ND	U	1	5	ND	U	1	5	ND	U	1	5
NAPHTHALENE	6.2	21	ND	U	1	2	196	0	10	20	207	0	5	10	ND	U	1	2	ND	U	1	2	
STYRENE	100	10	ND	U	0.5	1	ND	U	0.5	1	ND	U	0.5	1	ND	U	0.5	1	ND	U	0.5	1	
TETRACHLOROETHYLENE(PCE)	5	170	ND	U	0.5	1	ND	U	0.5	1	ND	U	0.5	1	ND	U	0.5	1	ND	U	0.5	1	
TOLUENE	1000	40	ND	U	0.5	1	ND	U	0.5	1	ND	U	0.5	1	ND	U	0.5	1	ND	U	0.5	1	
trans-1,2-DICHLOROETHENE	100	260	ND	U	0.5	1	ND	U	0.5	1	ND	U	0.5	1	ND	U	0.5	1	ND	U	0.5	1	
TRICHLOROETHYLENE (TCE)	5	310	ND	U	0.5	1	ND	U	0.5	1	ND	U	0.5	1	ND	U	0.5	1	ND	U	0.5	1	
VINYL CHLORIDE	2	3400	ND	U	0.5	1	ND	U	0.5	1	ND	U	0.5	1	ND	U	0.5	1	ND	U	0.5	1	
SW8270C	1-METHYLNAPHTHALENE	240	10	ND	U	0.25	0.99	72.1	0	0.96	3.8	59.4	0	0.96	3.8	ND	U	0.25	0.98	ND	U	0.24	0.97
	2-METHYLNAPHTHALENE	240	10	ND	U	0.25	0.99	30.3	0	0.24	0.96	26.2	0	0.24	0.96	ND	U	0.25	0.98	ND	U	0.24	0.97
	ACENAPHTHENE	370	20	ND	U	0.5	0.99	0.66	J	0.48	0.96	0.56	J	0.48	0.96	ND	U	0.49	0.98	ND	U	0.49	0.97
	ACENAPHTHYLENE	240	2000	ND	U	0.5	0.99	ND	U	0.48	0.96	ND	U	0.48	0.96	ND	U	0.49	0.98	ND	U	0.49	0.97
	ANTHRACENE	1800	22	ND	U	0.5	0.99	ND	U	0.48	0.96	ND	U	0.48	0.96	ND	U	0.49	0.98	ND	U	0.49	0.97
	BENZO(a)PYRENE	0.2	1.9	ND	U	0.099	0.2	ND	U	0.096	0.19	ND	U	0.096	0.19	ND	U	0.098	0.2	ND	U	0.097	0.19
	BENZO(b)FLUORANTHENE	0.092	7	ND	U	0.05	0.2	ND	U	0.048	0.19	ND	U	0.048	0.19	ND	U	0.049	0.2	ND	U	0.049	0.19
	BENZO(g,h,i)PERYLENE	1500	0.13	ND	U	0.099	0.2	ND	U	0.096	0.19	ND	U	0.096	0.19	ND	U	0.098	0.2	ND	U	0.097	0.19
	BENZO(k)FLUORANTHENE	0.92	0.4	ND	U	0.099	0.2	ND	U	0.096	0.19	ND	U	0.096	0.19	ND	U	0.098	0.2	ND	U	0.097	0.19
	CHRYSENE	9.2	0.8	ND	U	0.099	0.2	ND	U	0.096	0.19	ND	U	0.096	0.19	ND	U	0.098	0.2	ND	U	0.097	0.19
	DIBENZ(a,h)ANTHRACENE	0.0092	0.25	ND	U	0.05	0.2	ND	U	0.048	0.19	ND	U	0.048	0.19	ND	U	0.049	0.2	ND	U	0.049	0.19
	FLUORANTHENE	1500	130	ND	U	0.25	0.99	ND	U	0.24	0.96	ND	U	0.24	0.96	ND	U	0.25	0.98	ND	U	0.24	0.97
	FLUORENE	240	950	ND	U	0.25	0.99	0.26	J	0.24	0.96	0.26	U	0.24	0.96	ND	U	0.25	0.98	ND	U	0.24	0.97
	INDENO(1,2,3-c,d)PYRENE	0.092	0.27	ND	U	0.05	0.2	ND	U	0.048	0.19	ND	U	0.048	0.19	ND	U	0.049	0.2	ND	U	0.049	0.19
	NAPHTHALENE	6.2	21	ND	U	0.25	0.99	105	0	0.96	3.8	90.1	0	0.96	3.8	ND	U	0.25	0.98	ND	U	0.24	0.97
	PHENANTHRENE	240	410	ND	U	0.5	0.99	ND	U	0.48	0.96	ND	U	0.48	0.96	ND	U	0.49	0.98	ND	U	0.49	0.97
	PYRENE	180	68	ND	U	0.25	0.99	ND	U	0.24	0.96	ND	U	0.24	0.96	ND	U	0.25	0.98	ND	U	0.24	0.97
SW6010BFiltered	LEAD	15	50000	1.7	J	1.7	5	1.7	J	1.7	5	1.7	U	1.7	5	3	J	1.7	5	ND	U	1.7	5

UG/L - micrograms per Liter

Q - data qualifier

U - Indicates that the compound was analyzed for but not detected at or above the stated limit

J - Indicates an estimated value

MDL - method detection limit

RL - reporting limit

TPH - Total Petroleum hydrocarbons

ND - Indicates that the compound was analyzed for but not detected at or above the stated limit

200 - Result exceeds one or both HDOH EAL's

¹ Toxicity-based environmental action levels, Table D-2, *Screening For Environmental Concerns At Sites With Contaminated Soil and Groundwater*, HDOH, 2005

² Taste, odor and solubility thresholds, Table G-1, *Screening For Environmental Concerns At Sites With Contaminated Soil and Groundwater*, HDOH, 2005

Technical Report for

The Environmental Company

Red Hill Bulk Storage Facility, HI

7707-009

Accutest Job Number: F35142

Sampling Date: 09/20/05

Report to:

jshart@tecinc.com
snmacmillan@tecinc.com

ATTN: Distribution3

Total number of pages in report: **319**



Test results contained within this data package meet the requirements of the National Environmental Laboratory Accreditation Conference and/or state specific certification programs as applicable.

Harry Behzadi, Ph.D.
Laboratory Director

Certifications: FL (DOH E83510), NC (573), NJ (FL002), MA (FL946), IA (366), LA (03051), KS (E-10327), SC, AK
This report shall not be reproduced, except in its entirety, without the written approval of Accutest Laboratories.

Table of Contents

-1-

Section 1: Sample Summary	4
Section 2: Case Narrative/Conformance Summary	5
Section 3: Sample Results	9
3.1: F35142-1: RHMW01W01	9
3.2: F35142-2: RHMW02W01	17
3.3: F35142-2A: RHMW02W01	28
3.4: F35142-3: RHMW03W01	29
3.5: F35142-3A: RHMW03W01	40
3.6: F35142-4: RHMW02Q01	41
3.7: F35142-4A: RHMW02Q01	52
3.8: F35142-5: RHMW04W01	53
3.9: F35142-6: RHMW2254W01	59
3.10: F35142-7: TRIP BLANK	64
Section 4: Misc. Forms	67
4.1: Chain of Custody	68
Section 5: GC/MS Volatiles - QC Data Summaries	75
5.1: Method Blank Summary	76
5.2: Blank Spike Summary	85
5.3: Matrix Spike/Matrix Spike Duplicate Summary	94
5.4: Instrument Performance Checks (BFB)	103
5.5: Internal Standard Area Summaries	108
5.6: Surrogate Recovery Summaries	111
5.7: Initial and Continuing Calibration Summaries	112
Section 6: GC/MS Semi-volatiles - QC Data Summaries	135
6.1: Method Blank Summary	136
6.2: Blank Spike Summary	138
6.3: Matrix Spike/Matrix Spike Duplicate Summary	139
6.4: Instrument Performance Checks (DFTPP)	140
6.5: Internal Standard Area Summaries	144
6.6: Surrogate Recovery Summaries	146
6.7: Initial and Continuing Calibration Summaries	147
Section 7: GC Volatiles - QC Data Summaries	152
7.1: Method Blank Summary	153
7.2: Blank Spike Summary	158
7.3: Matrix Spike/Matrix Spike Duplicate Summary	163
7.4: Matrix Spike Summary	167
7.5: Duplicate Summary	168
7.6: Surrogate Recovery Summaries	172
7.7: GC Surrogate Retention Time Summaries	174
7.8: Initial and Continuing Calibration Summaries	182
Section 8: GC Semi-volatiles - QC Data Summaries	206
8.1: Method Blank Summary	207

Table of Contents

-2-

8.2: Blank Spike Summary	209
8.3: Matrix Spike/Matrix Spike Duplicate Summary	212
8.4: Duplicate Summary	214
8.5: Surrogate Recovery Summaries	215
8.6: GC Surrogate Retention Time Summaries	217
8.7: Initial and Continuing Calibration Summaries	220
Section 9: Metals Analysis - QC Data Summaries	230
9.1: Inst QC MA4585: Ca,Pb,Mg,K,Na	231
9.2: Inst QC MA4590: Ca	246
9.3: Prep QC MP8655: Ca,Pb,Mg,K,Na	269
9.4: IDL and Linear Range Summaries	274
Section 10: General Chemistry - QC Data Summaries	276
10.1: Method Blank and Spike Results Summary	277
10.2: Duplicate Results Summary	278
10.3: Matrix Spike Results Summary	279
10.4: Matrix Spike Duplicate Results Summary	280
10.5: Inst QC GN18504: Chloride,Fluoride	281
10.6: Inst QC GN18624: Sulfate	283
10.7: Inst QC GN18626: Sulfate	286
Section 11: Metals Analysis - QC Data (Accutest New Jersey)	289
11.1: Inst QC MA16401: Sr	290
11.2: Prep QC MP31729: Sr	313
11.3: IDL and Linear Range Summaries	318

1

2

3

4

5

6

7

8

9

10

11

Appendix E
Groundwater Treatment Technologies

1. COMPONENT NAVY	FY 07 MILITARY CONSTRUCTION PROJECT DATA			2. DATE AUG 1999			
3. INSTALLATION AND LOCATION/UIC: N62755 NAVY PUBLIC WORKS CENTER PEARL HARBOR, HAWAII		4. PROJECT TITLE WATER PURIFICATION FACILITY AT WAIAWA WATER PUMPING PLANT					
5. PROGRAM ELEMENT	6. CATEGORY CODE 841.10	7. PROJECT NUMBER P-489	8. PROJECT COST (\$000) 28,300				
9. COST ESTIMATES							
ITEM	U/M	QUANTITY	UNIT COST	COST (\$000)			
WATER PURIFICATION FACILITY	LS			24,420			
GAC WATER TREATMENT FILETERS	EA	45	483,778	(21,770)			
MODIFY EXISTING WAIAWA PUMPS	EA	4	552,500	(2,090)			
LABORATORY	m ²	56	10,000	(560)			
SUPPORTING FACILITIES	SL			910			
SUBTOTAL				25,330			
CONTINGENCY (5%)				1,729			
TOTAL CONTRACT COST				26,597			
SIOH (6.5%)				1,729			
TOTAL REQUEST				28,326			
TOTAL REQUEST (ROUNDED)				28,300			
EQUIPMENT FROM OTHER APPROPRIATIONS			(NON-ADD)	(90)			
COLLATERAL EQUIPMENT				(0)			
GUIDANCE COST ANALYSIS							
CATEGORY CODE	U/M	GUIDANCE COST	GUIDANCE SIZE	PROJECT SCOPE	SIZE FACTOR	AREA COST FACTOR	ADJ UNIT COST
NOT APPLICABLE							
10. DESCRIPTION OF PROPOSED CONSTRUCTION							
<p>Construct a water purification facility and appurtenances for the removal of dibromochloropropane (DBCP) and trichloropropane (TCP) pesticides from the Waiawa Water Pumping Plant. The proposed construction will include a granular activated carbon (GAC) filter system with pumps, concrete tanks, mechanical piping, and electrical controls. Existing pumps at the Waiawa Water Pumping Plant will be modified as required. A 56 m² (600 SF) laboratory for analysis of water samples for DBCP and TCP will also be constructed.</p>							
11. REQUIREMENT: _____ m ² Adequate: _____ m ² Substandard: _____ m ²							
Non-BFR Item							
(CONTINUED ON DD1391C+)							
REQUIRED PRE-PCE STUDIES							
N/A.							
NEPA COMPLIANCE							
ANTICIPATED NEPA DOCUMENTATION REQUIRED FOR THIS PROJECT IS: CATEX <u>X</u> EA <u> </u> EIS <u> </u> .							
START DATE TO SUPPORT PROPOSED FISCAL YEAR IS: <u>Jul 2005</u> ESTIMATED COMPLETION DATE IS: <u>Sept 2005</u> .							
TOTAL ESTIMATED COST FOR NEPA AND ASSOCIATED STUDIES IS: <u>\$ 3,000</u> .							

1. COMPONENT NAVY	FY <u>07</u> MILITARY CONSTRUCTION PROJECT DATA	2. DATE AUG 1999
3. INSTALLATION AND LOCATION NAVY PUBLIC WORKS CENTER PEARL HARBOR, HAWAII		
4. PROJECT TITLE WATER PURIFICATION FACILITY AT WAIAWA WATER PUMPING PLANT	5. PROJECT NUMBER P-489	
<p><u>SCOPE:</u></p> <p>The scope was derived using the State of Hawaii, Department of Health (DOH) Administrative Rules (HAR) Title 11, Chapter 20: Rules Relating to Potable Water Systems (11-20-4) which regulates both DBCP and TCP, and the Environmental Protection Agency (EPA) 40 CFR Part 141: National Primary Drinking Water Regulations (40 CFR 141.24) which also regulates DBCP.</p> <p><u>PROJECT:</u></p> <p>This project will construct a water purification facility and laboratory in compliance with State DOH and EPA regulations. (Current Mission)</p> <p><u>REQUIREMENT:</u></p> <p>A safe and reliable water system is required to support the Navy community. The Waiawa Pumping Plant provides approximately 65 to 75 percent of the fresh water requirement for the Pearl Harbor complex. Other Navy water sources will not be able to meet the increased daily water demand caused by closure of this plant, even by pumping at higher rates (which reduces water quality). The proposed water purification facility is required to reduce levels of DBCP and TCP pesticides in the Navy's water supply. A testing laboratory is also required for analysis of water samples to ensure that levels of DBCP or TCP do not exceed acceptable limits.</p> <p>The mission of Navy Public Works Center (PWC) is to be the Navy's Regional Public Works provider and serve the Navy, Marine Corps team, DoD and other Governmental agencies in Hawaii. PWC is committed to giving their customers the best value possible in terms of service and cost.</p> <p><u>CURRENT SITUATION:</u></p> <p>Trace amounts of DBCP and TCP pesticides were discovered in the Navy's Waiawa water supply. The State Department of Health (DOH) has advised the Navy of possible closure of Waiawa wells if the concentration of DBCP or TCP exceed acceptable levels. The Waiawa Water Pumping Plant does not have treatment facilities for the removal of DBCP or TCP contaminants. Similarly, there are no treatment facilities within the Pearl Harbor Naval Complex water distribution system for removal of DBCP or TCP. These contaminants pose a serious health problem to water users in Pearl Harbor. With the possible closure of the Waiawa water source by the DOH and EPA due to DBCP and TCP contamination, the Navy will not be able to satisfy the daily water demand. Dependence on other Navy water sources to meet the demand could seriously jeopardize the quality of groundwater in these areas because of salt water intrusion and lowering of the water table.</p> <p><u>IMPACT IF NOT PROVIDED:</u></p> <p>If DBCP and TCP pesticides are detected and exceed acceptable level, these contaminants pose a serious health problem to water users and will require the closure of the Waiawa water source. The Navy will not be able to satisfy the daily water demand and will seriously impact fleet readiness.</p>		



Remediation Technologies Screening Matrix and Reference Guide, Version 4.0

4.36 Dual Phase Extraction (In Situ GW Remediation Technology)

Description
Data Needs

Synonyms
Performance

Applicability
Cost

Limitations
References

Site Information
Vendor Info.

Points of Contact
Health & Safety

Home

Table of Contents

Introduction

Contaminants

Treatments/Profiles

References

Appendices

Navigation

Technology>> Ground Water, Surface Water, and Leachate

>>3.10 In Situ Physical/Chemical Treatment

>>4.36 Dual Phase Extraction

Introduction>> A high vacuum system is applied to simultaneously remove various combinations of contaminated ground water, separate-phase petroleum product, and hydrocarbon vapor from the subsurface.

Description:

[Figure 4-36:
Typical Dual Phase Extraction Schematic](#)

Dual-phase extraction (DPE), also known as multi-phase extraction, vacuum-enhanced extraction, or sometimes bioslurping, is a technology that uses a high vacuum system to remove various combinations of contaminated ground water, separate-phase petroleum product, and hydrocarbon vapor from the subsurface. Extracted liquids and vapor are treated and collected for disposal, or re-injected to the subsurface (where permissible under applicable state laws).

In DPE systems for liquid/vapor treatment, a high vacuum system is utilized to remove liquid and gas from low permeability or heterogeneous formations. The vacuum extraction well includes a screened section in the zone of contaminated soils and ground water. It removes contaminants from above and below the water table. The system lowers the water table around the well, exposing more of the formation. Contaminants in the newly exposed vadose zone are then accessible to vapor extraction. Once above ground, the extracted vapors or liquid-phase organics and ground water are separated and treated. DPE for liquid/vapor treatment is generally combined with bioremediation, air sparging, or bioventing when the target contaminants include long-chained hydrocarbons. Use of dual phase extraction with these technologies can shorten the cleanup time at a site. It also can be used with pump-and-treat technologies to recover ground water in higher-yielding aquifers.

TOP ▲

Synonyms:

Multi-phase extraction; Vacuum-enhanced extraction; Free product recovery; Liquid-Liquid Extraction.

DSERTS Code:

(Dual-phase extraction)
F13 (Free product recovery)

▲

Applicability:

The target contaminant groups for dual phase extraction are VOCs and fuels (e.g., LNAPLs). Dual phase vacuum extraction is more effective than SVE for heterogeneous clays and fine sands. However, it is not recommended for lower permeability formations due to the potential to leave isolated lenses of undissolved product in the formation.

TOP ▲

Limitations:

Factors that may limit the applicability and effectiveness of the process include:

- Site geology and contaminant characteristics/distribution.
- Combination with complementary technologies (e.g., pump-and-treat) may be required to recover ground water from high yielding aquifers.
- Dual phase extraction requires both water treatment and vapor treatment.

TOP ▲

Data Needs:

A detailed discussion of these data elements is provided in [Subsection 2.2.2](#). (Data Requirements for Ground Water, Surface Water, and Leachate).

Data needs include physical and chemical properties of the product released (e.g., viscosity, density, composition, depth, and solubility in water); soil properties (e.g., capillary forces, effective porosity, moisture content, organic content, hydraulic conductivity, and texture); nature of the release (e.g., initial date of occurrence, duration, volume, and rate); geology (e.g., stratigraphy that promotes trapped pockets of free product); hydrogeologic regime (e.g., permeability, depth to water table, ground water flow direction, and gradient); and anticipated product recharge rate.

TOP ▲

Performance Data:

Once contaminants are detected, the immediate response should include both removal of the source and recovery of product by the most expedient means. Dual Phase Extraction methods will extract contaminated water with the product. It may be necessary to separate water and product prior to disposal or recycling of the product. As a result of the removal of substantial quantities of water during dual pumping operations, on-site water treatment will normally be required. When treatment of recovered water is required, permits will usually be necessary.

TOP ▲

Cost:

Because of the number of variances involved, establishing general costs for dual phase extraction is difficult. Some representative costs are \$500 per month for a single phase extraction (hand bailing) system; \$1,200 to \$2,000 per month for a single phase extraction (skimming) system; and \$2,500 to \$4,000 per month for a dual pumping system. These costs illustrate the relative magnitudes of the various recovery options available, which are typically less than other types of remediation.

Key cost factors for the recovery of free product include waste disposal, potential for sale of recovered product for recycling, on-site equipment rental (e.g., pumps, tanks, treatment systems), installation of permanent equipment, and engineering and testing costs.

Estimated cost ranges per site are between \$85,000 to \$500,000 per site.



References:

[Treatment Technologies for Site Cleanup: Annual Status Report \(ASR\), Tenth Edition, EPA 542-R-01-004](#)

[Innovative Remediation Technologies: Field Scale Demonstration Project in North America, 2nd Edition](#)

[Abstracts of Remediation Case Studies, Volume 4, June, 2000, EPA 542-R-00-006](#)

[Guide to Documenting and Managing Cost and Performance Information for Remediation Projects - Revised Version, October, 1998, EPA 542-B-98-007](#)

American Petroleum Institute, 1989. *A Guide to the Assessment and Remediation of Underground Petroleum Releases*, Publication 1628, API, Washington, DC, 81 pp.

[MTBE Treatment Case Studies](#) presented by the USEPA Office of Underground Storage Tanks.

[DOE, 1994. Technology Application Analysis: Petroleum Product Recovery and Contaminated Groundwater Remediation Amoco Petroleum Pipeline Constantine, MI, prepared by Stone & Webster Environmental Technology & Services.](#)

[DOE, 1994. Technology Application Analysis: Recovery of Free Petroleum Product Fort Drum, Fuel Dispensing Area 1595 Watertown, New York, prepared by Stone & Webster Environmental Technology & Services.](#)

EPA, 1988. *Cleanup of Releases from Petroleum USTs: Selected Technologies*, Washington, DC, EPA/530/UST-88/001.

[EPA, 1997. Analysis of Selected Enhancements for Soil Vapor Extraction, EPA OSWER, EPA/542/R-97/007.](#)

[FRTR, 1998. Remediation Case Studies: Six Phase Soil Heating at the U.S. Department of Energy's Savannah River Site, M Area, Aiken, South Carolina; and Hanford Site, 300-Area, Richland, Washington.](#)

Kram, M.L., 1990. "Measurement of Floating Petroleum Product Thickness and Determination of Hydrostatic Head in Monitoring Wells", NEESA Energy and Environmental News Information Bulletin No. 1B-107.

Kram, M.L., 1993. "Free Product Recovery: Mobility Limitations and Improved Approaches", NFESC Information Bulletin No. IB-123.

NEESA, 1992. *Immediate Response to Free Product Discovery*, NEESA Document No. 20.2-051.4.



Site Information:

- [Amoco Petroleum Pipeline Constantine, MI](#)
- [Fort Drum, Watertown, NY](#)
- [March Air Force Base, CA](#)
- [Lockheed Aeronautical Systems Co., Burbank, CA](#)
- [Major Car Rental Agency, Los Angeles, CA](#)
- [Navy Fuel Farm](#)
- [Privately Owned Gasoline Station Near Urban Drinking Water Source](#)
- [Additional site information on the FRTR web site](#)

Points of Contact:

[TOP](#) [General FRTR Agency Contacts](#)

Technology Specific Web Sites:

[Government Web Sites](#)[Non Government Web Sites](#)

Vendor Information:

[TOP](#) 

[A list of vendors offering In Situ Physical/Chemical Water Treatment](#) is available from [EPA REACH IT](#) which combines information from three established EPA databases, the Vendor Information System for Innovative Treatment Technologies (VISITT), the Vendor Field Analytical and Characterization Technologies System (Vendor FACTS), and the Innovative Treatment Technologies (ITT), to give users access to comprehensive information about treatment and characterization technologies and their applications.

[Government Disclaimer](#)

Health and Safety:

[TOP](#) [Hazard Analysis](#)[TOP](#) 



Remediation Technologies Screening Matrix and Reference Guide, Version 4.0

4.29 Enhanced Bioremediation (In Situ GW Remediation Technology)

Description
Data Needs

Synonyms
Performance

Applicability
Cost

Limitations
References

Site Information
Vendor Info.

Points of Contact
Health & Safety

Home

Table of Contents

Introduction

Contaminants

Treatments/Profiles

References

Appendices

Navigation

Technology>> Ground Water, Surface Water, and Leachate

>>3.9 In Situ Biological Treatment

>>4.29 Enhanced Bioremediation

Introduction>>

The rate of bioremediation of organic contaminants by microbes is enhanced by increasing the concentration of electron acceptors and nutrients in water, surface water, and leachate. Oxygen is the main electron acceptor for aerobic bioremediation. Nitrate serves as an alternative electron acceptor under anoxic conditions.

Description:

Figure 4-29a:

[Typical Oxygen-Enhanced Bioremediation System for Contaminated Ground water with Air Sparging](#)

Figure 4-29b:

[Oxygen-Enhanced H₂O₂ Bioremediation System](#)

Figure 4-29c:

[Typical Nitrate-Enhanced Bioremediation System](#)

Bioremediation is a process in which indigenous or inoculated micro-organisms (i.e., fungi, bacteria, and other microbes) degrade (metabolize) organic contaminants found in soil and/or ground water.

Bioremediation is a process that attempts to accelerate the natural biodegradation process by providing nutrients, electron acceptors, and competent degrading microorganisms that may otherwise be limiting the rapid conversion of contamination organics to innocuous end products.

Oxygen enhancement can be achieved by either sparging air below the water table or circulating hydrogen peroxide (H₂O₂) throughout the contaminated ground water zone.

Under anaerobic conditions, nitrate is circulated throughout the ground water contamination zone to enhance bioremediation. Additionally, solid-phase peroxide products (e.g., oxygen releasing compound (ORC)) can also be used for oxygen enhancement and to increase the rate of biodegradation.

➤ *Oxygen Enhancement with Air Sparging*

Air sparging below the water table increases ground water oxygen concentration and enhances the rate of biological degradation of organic contaminants by naturally occurring microbes. (VOC stripping enhanced by air sparging is addressed in [Technology Profile 4.34](#)). Air sparging also increases mixing in the saturated zone, which increases the contact between ground water and soil. The ease and low cost of installing small-diameter

air injection points allows considerable flexibility in the design and construction of a remediation system. Oxygen enhancement with air sparging is typically used in conjunction with SVE or bioventing to enhance removal of the volatile component under consideration.

➤ *Oxygen Enhancement with Hydrogen Peroxide*

During hydrogen peroxide enhancement, a dilute solution of hydrogen peroxide is circulated through the contaminated ground water zone to increase the oxygen content of ground water and enhance the rate of aerobic biodegradation of organic contaminants by naturally occurring microbes.

➤ *Nitrate Enhancement*

Solubilized nitrate is circulated throughout ground water contamination zones to provide an alternative electron acceptor for biological activity and enhance the rate of degradation of organic contaminants. Development of nitrate enhancement is still at the pilot scale. This technology enhances the anaerobic biodegradation through the addition of nitrate.

Fuel has been shown to degrade rapidly under aerobic conditions, but success often is limited by the inability to provide sufficient oxygen to the contaminated zones as a result of the low water solubility of oxygen and because oxygen is rapidly consumed by aerobic microbes. Nitrate also can serve as an electron acceptor and is more soluble in water than oxygen. The addition of nitrate to an aquifer results in the anaerobic biodegradation of toluene, ethylbenzene, and xylenes. The benzene component of fuel has been found to biodegrade slower under strictly anaerobic conditions. A mixed oxygen/nitrate system would prove advantageous in that the addition of nitrate would supplement the demand for oxygen rather than replace it, allowing for benzene to be biodegraded under microaerophilic conditions.

These technologies may be classified as long-term technologies, which may take several years for plume clean-up.

TOP ▲

Synonyms:

Biostimulation, bioaugmentation.
DSERTS Codes:

F11 (Bioremediation - In Situ Groundwater)
H1 (Bioremediation)
H12 (Bioremediation - In Situ)

TOP ▲

Applicability:

Target contaminants for enhanced biodegradation processes are nonhalogenated VOCs, nonhalogenated SVOCs, and fuels. Pesticides also should have limited treatability. Nitrate enhancement has primarily been used to remediate ground water contaminated by BTEX.

TOP ▲

Limitations:

Factors that may limit the applicability and effectiveness of these processes include:

- Where the subsurface is heterogeneous, it is very difficult to deliver the nitrate or hydrogen peroxide solution throughout every portion of the contaminated zone. Higher permeability zones will be cleaned up much faster because ground water flow rates are greater.
- Safety precautions must be used when handling hydrogen peroxide.
- Concentrations of hydrogen peroxide greater than 100 to 200 ppm in ground water are inhibiting to microorganisms.
- Microbial enzymes and high iron content of subsurface materials can rapidly reduce concentrations of hydrogen peroxide and reduce zones of influence.
- A ground water circulation system must be created so that contaminants do not escape from zones of active biodegradation.
- Because air sparging increases pressure in the vadose zone, vapors can build up in building basements, which are generally low pressure areas.
- Many states prohibit nitrate injection into ground water because nitrate is regulated through drinking water standards.
- A surface treatment system, such as air stripping or carbon adsorption, may be required to treat extracted ground water prior to re-injection or disposal.

TOP ▲

Data Needs:

A detailed discussion of these data elements is provided in [Subsection 2.2.2](#) (Data Requirements for Ground Water, Surface Water, and Leachate).

Characteristics that should be investigated prior to system design include aquifer permeability, site hydrology, dissolved oxygen content, pH, and depth, type, concentration, redox conditions, temperature, biodegradability of contaminants, and the presence of a competent biodegrading population of microorganisms.

TOP ▲

Performance Data:

As with other in situ biodegradation processes, the success of this technology is highly dependent upon soil properties and biodegradability of the contaminants.

Although oxygen enhancement with air sparging is relatively new, the related technology, bioventing ([Treatment Technology Profile 4.1](#)), is rapidly receiving increased attention from remediation consultants. This technology employs the same concepts as bioventing, except that air is injected below the water table to promote the remediation of ground water.

TOP ▲

Cost:

For oxygen enhancement with air sparging, typical costs are \$10 to \$20 per 1,000 liters (\$40 to \$80 per 1,000 gallons) of ground water treated. Variables affecting the cost are the nature and depth of the contaminants, use of bioaugmentation and/or hydrogen peroxide or nitrate addition, and ground water pumping rates.

For nitrate enhanced treatment, one cost estimate is in the range of \$40 to \$60 per liter (\$160 to \$230 per gallon) of residual fuel removed from the aquifer.

For hydrogen peroxide enhanced treatment, costs are an order of magnitude more expensive than other methods of oxygen enhancement. O&M cost of hydrogen peroxide

enhancement can be significant because a continuous source of hydrogen peroxide must be delivered to the contaminated ground water.



References:

[Treatment Technologies for Site Cleanup: Annual Status Report \(ASR\), Tenth Edition, EPA 542-R-01-004](#)

[Innovative Remediation Technologies: Field Scale Demonstration Project in North America, 2nd Edition](#)

[Remediation Technology Cost Compendium - Year 2000](#)

[Groundwater Cleanup: Overview of Operating Experience at 28 Sites, September 1999, EPA 542-R-99-006,](#)

[Treatment Experiences at RCRA Corrective Actions, December 2000, EPA 542-F-00-020](#)

[Abstracts of Remediation Case Studies, Volume 4, June, 2000, EPA 542-R-00-006](#)

[Guide to Documenting and Managing Cost and Performance Information for Remediation Projects - Revised Version, October, 1998, EPA 542-B-98-007](#)

[MTBE Treatment Case Studies](#) presented by the USEPA Office of Underground Storage Tanks.

[Emerging Technologies for Enhanced In Situ Bionitrification \(EISBD\) of Nitrate Contaminated Ground Water](#), The Interstate Technology and Regulatory Cooperation Work Group (ITRC) In Situ Bionitrification Work Team, April 2000

The [EPA's Treatment Technologies for Site Cleanup Annual Status Report, Tenth Edition](#), documents the status, as of the summer of 2000, of treatment technology applications for soil, other solid wastes, and groundwater at Superfund sites.

[Technology Evaluation Report: Technologies for Dense Nonaqueous Phase Liquid Source Zone Remediation](#), Ground-Water Remediation Technologies Analysis Center (GWRTAC), December 1998.

Acree, S.D. et al. 1997. "Site Characterization Methods of the Design of In Situ Donor Delivery Systems," *In Situ and On Site Bioremediation: Volume 4*. B.C. Alleman and A. Leeson. Battelle Press, Columbus, OH.

Dey, C.D., R.A. Brown, and W.E. McFarland, 1991. "Integrated Site Remediation Combining Groundwater Treatment, Soil Vapor Recovery, and Bioremediation," *Hazardous Materials Control*, Vol. 4, No. 2, pp. 32-39, March/April 1991.

[EPA, 1992. In Situ Bioremediation of Contaminated Ground Water, EPA/540/S-92/003; NTIS: PB92-224336.](#)

[EPA, 1997. Anaerobic Biodegradation of BTEX in Aquifer Material, EPA/600/S-97/003.](#)

[EPA, 1997. Bioremediation of BTEX, Naphthalene, and Phenanthrene in Aquifer Material Using Mixed Oxygen/Nitrate Electron Acceptor Conditions, EPA/600/SR-97/103.](#)

Federal Remediation Technologies Roundtable, 1997. *Remediation Case Studies: Soil*

Vapor Extraction and Other In Situ Technologies, EPA/542/R-97/009.

- [In Situ Enhanced Soil Mixing at the U.S. Department of Energy's Portsmouth Gaseous Diffusion Plant, X-231B Unit, Piketon, Ohio](#)

Federal Remediation Technologies Roundtable, 1998. *Remediation Case Studies: Innovative Groundwater Treatment Technologies*, EPA/542/R-98/015.

- [Enhanced Bioremediation of Contaminated Groundwater - Balfour Road Site, Brentwood, CA; Fourth Plain Service Station Site, Vancouver, WA; Steve's Standard and Golden Belt 66 Site, Great Bend, KS](#)
- [In Situ Anaerobic Bioremediation at DOE's Pinellas Northeast Site, Largo, Florida](#)
- [Pump and Treat and In Situ Bioremediation of Contaminated Groundwater at the French Ltd. Superfund Site, Crosby, Texas](#)
- [Pump and Treat and In Situ Bioremediation of Contaminated Groundwater at the Libby Groundwater Superfund Site, Libby, Montana](#)
- [Pump and Treat, In Situ Bioremediation, and In Situ Air Sparging of Contaminated Groundwater at Site A, Long Island, New York](#)

Hutchins, S.R., G.W. Sewell, D.A. Kovacs, and G.A. Smith, 1991. "Biodegradation of Aromatic Hydrocarbons by Aquifer Microorganisms Under Denitrifying Conditions," *Environmental Science and Technology*, No. 25, pp. 68-76.

[Technology Catalogue, Second Edition, April 1995](#)

[Treatment Technologies Applications Matrix for Base Closure Activities, November 1994](#)

U.S. Department of Commerce, National Technical Information Service(NTIS), May 1991. "Nitrate for Bioremediation of an Aquifer Contaminated with Jet Fuel".



Site Information:

- Watertown, MA
- Bendena Site, KS
- UST site 23, Naval Air Station Point Mugu, CA
- Natural Gas Pipeline Compressor Station, VA
- Unidentified Site, Lansing, MI
- Formerly JimBo's Gas N'Goodies, Aiken, SC
- Dry Cleaning Facility
- Columbia County Landfill, GA
- Denver Federal Center, CO
- Hanford 200 Area
- ORNL, Oak Ridge, TN
- Edwards AFB, CA
- [Naval Communication Station, Scotland](#)
- [DOE Demo Savannah River Site, SC](#)
- [EPA Demo Williams AFB, AZ](#)
- [DOE Savannah River Site, SC](#)
- [DOE Demo Hanford Site, WA](#)
- [NAS Fallon, NV](#)
- [Air Force & DOE Demo Tinker AFB, OK](#)
- [Air Force Demo Eglin, AFB, FL](#)
- [Air Force Demo Kelly AFB, TX & Eglin AFB, FL](#)
- [DOI Demo Picatinny Arsenal, NJ](#)
- [DOI Demo Defense Fuel Supply Point, SC](#)

- [DOE Tech Demo \(USGS\) Galloway Township, NJ](#)
- [Stalworth Timber Beatrice, AL](#)
- [Park City, KS](#)
- [Mayville Fire Department Mayville, MI](#)
- [Dover AFB, Dover, DE](#)
- [Knispel Construction Site, Horseheads, NJ](#)
- [Orkin Facility, Fort Pierce, FL](#)
- [Farfield Coal & Gas, Farfield, IA](#)
- [DOE K-25 Site](#)
- [Libby Ground Water Superfund Site](#)
- [Public Service Company of Colorado, CO](#)
- [Kennedy Space Center, FL](#)
- [DOE's Portsmouth Gaseous Diffusion Plant, X-231B Unit, Piketon, OH](#)
- [Balfour Road Site, Brentwood, CA; Fourth Plain Service Station Site, Vancouver, WA; Steve's Standard and Golden Belt 66 Site, Great Bend, KS](#)
- [DOE's Pinellas Northeast Site, Largo, FL](#)
- [French Ltd. Superfund Site, Crosby, TX](#)
- [Site A, Long Island, NY](#)
- [Additional site information on the FRTR web site](#)

Points of Contact:

TOP ▲

[General FRTR Agency Contacts](#)

Technology Specific Web Sites:

[Government Web Sites](#)

[Non Government Web Sites](#)

Vendor Information:

TOP ▲

A list of vendors offering [In Situ Biological Water Treatment](#) is available from [EPA REACH IT](#) which combines information from three established EPA databases, the Vendor Information System for Innovative Treatment Technologies (VISITT), the Vendor Field Analytical and Characterization Technologies System (Vendor FACTS), and the Innovative Treatment Technologies (ITT), to give users access to comprehensive information about treatment and characterization technologies and their applications.

[Government Disclaimer](#)

Health and Safety:

TOP ▲

[Hazard Analysis](#)

TOP ▲



TABLE 3-2: TREATMENT TECHNOLOGIES SCREENING MATRIX

Rating Codes ● Above Average ● Average ○ Below Average N/A - "Not Applicable" I/D - "Insufficient Data" ◇ - Level of Effectiveness highly dependent upon specific contaminant and its application	Development Status	Treatment Train	Relative Overall Cost & Performance										Nonhalogenated VOC's	Halogenated VOC's	Nonhalogenated SVOC's	Halogenated SVOC's	Fuels	Inorganics	Radionuclides	Explosives
			O&M	Capital	System Reliability & Maintainability	Relative Costs	Time	Availability												
Soil, Sediment, Bedrock, and Sludge																				
3.1 In Situ Biological Treatment																				
4.1 Bioventing	●	●	●	●	●	●	●	●	●	●	●	●	●	●	●	●	●	●	●	●
4.2 Enhanced Bioremediation	●	●	●	●	●	●	●	●	●	●	●	●	●	●	●	●	●	●	●	●
4.3 Phytoremediation	●	●	●	●	●	●	●	●	●	●	●	●	●	●	●	●	●	●	●	●
3.2 In Situ Physical/Chemical Treatment																				
4.4 Chemical Oxidation	●	●	●	●	●	●	●	●	●	●	●	●	●	●	●	●	●	●	●	●
4.5 Electrokinetic Separation	●	●	●	●	●	●	●	●	●	●	●	●	●	●	●	●	●	●	●	●
4.6 Fracturing	●	●	●	●	●	●	●	●	●	●	●	●	●	●	●	●	●	●	●	●
4.7 Soil Flushing	●	●	●	●	●	●	●	●	●	●	●	●	●	●	●	●	●	●	●	●
4.8 Soil Vapor Extraction	●	●	●	●	●	●	●	●	●	●	●	●	●	●	●	●	●	●	●	●
4.9 Solidification/Stabilization	●	●	●	●	●	●	●	●	●	●	●	●	●	●	●	●	●	●	●	●
3.3 In Situ Thermal Treatment																				
4.10 Thermal Treatment	●	●	●	●	●	●	●	●	●	●	●	●	●	●	●	●	●	●	●	●
3.4 Ex Situ Biological Treatment (assuming excavation)																				
4.11 Biopiles	●	●	●	●	●	●	●	●	●	●	●	●	●	●	●	●	●	●	●	●
4.12 Composting	●	●	●	●	●	●	●	●	●	●	●	●	●	●	●	●	●	●	●	●
4.13 Landfarming	●	●	●	●	●	●	●	●	●	●	●	●	●	●	●	●	●	●	●	●
4.14 Slurry Phase Biological Treatment	●	●	●	●	●	●	●	●	●	●	●	●	●	●	●	●	●	●	●	●
3.5 Ex Situ Physical/Chemical Treatment (assuming excavation)																				
4.15 Chemical Extraction	●	●	●	●	●	●	●	●	●	●	●	●	●	●	●	●	●	●	●	●
4.16 Chemical Reduction/Oxidation	●	●	●	●	●	●	●	●	●	●	●	●	●	●	●	●	●	●	●	●
4.17 Dehalogenation	●	●	●	●	●	●	●	●	●	●	●	●	●	●	●	●	●	●	●	●
4.18 Separation	●	●	●	●	●	●	●	●	●	●	●	●	●	●	●	●	●	●	●	●
4.19 Soil Washing	●	●	●	●	●	●	●	●	●	●	●	●	●	●	●	●	●	●	●	●
4.20 Solidification/Stabilization	●	●	●	●	●	●	●	●	●	●	●	●	●	●	●	●	●	●	●	●
3.6 Ex Situ Thermal Treatment (assuming excavation)																				
4.21 Hot Gas Decontamination	●	●	●	●	●	●	●	●	●	●	●	●	●	●	●	●	●	●	●	●
4.22 Incineration	●	●	●	●	●	●	●	●	●	●	●	●	●	●	●	●	●	●	●	●
4.23 Open Burn/Open Detonation	●	●	●	●	●	●	●	●	●	●	●	●	●	●	●	●	●	●	●	●
4.24 Pyrolysis	●	●	●	●	●	●	●	●	●	●	●	●	●	●	●	●	●	●	●	●
4.25 Thermal Desorption	●	●	●	●	●	●	●	●	●	●	●	●	●	●	●	●	●	●	●	●
3.7 Containment																				
4.26 Landfill Cap	●	●	●	●	●	●	●	●	●	●	●	●	●	●	●	●	●	●	●	●
4.27 Landfill Cap Enhancements/Alternatives	●	●	●	●	●	●	●	●	●	●	●	●	●	●	●	●	●	●	●	●
3.8 Other Treatment																				
4.28 Excavation, Retrieval, Off-Site Disposal	●	●	●	●	●	●	●	●	●	●	●	●	●	●	●	●	●	●	●	●
Ground Water, Surface Water, and Leachate																				
3.9 In Situ Biological Treatment																				
4.29 Enhanced Bioremediation	●	●	●	●	●	●	●	●	●	●	●	●	●	●	●	●	●	●	●	●
4.30 Monitored Natural Attenuation	●	●	●	●	●	●	●	●	●	●	●	●	●	●	●	●	●	●	●	●
4.31 Phytoremediation	●	●	●	●	●	●	●	●	●	●	●	●	●	●	●	●	●	●	●	●
3.10 In Situ Physical/Chemical Treatment																				
4.32 Air Sparging	●	●	●	●	●	●	●	●	●	●	●	●	●	●	●	●	●	●	●	●
4.33 Biosparging	●	●	●	●	●	●	●	●	●	●	●	●	●	●	●	●	●	●	●	●
4.34 Chemical Oxidation	●	●	●	●	●	●	●	●	●	●	●	●	●	●	●	●	●	●	●	●
4.35 Directional Wells (enhancement)	●	●	●	●	●	●	●	●	●	●	●	●	●	●	●	●	●	●	●	●
4.36 Dual Phase Extraction	●	●	●	●	●	●	●	●	●	●	●	●	●	●	●	●	●	●	●	●
4.37 Thermal Treatment	●	●	●	●	●	●	●	●	●	●	●	●	●	●	●	●	●	●	●	●
4.38 Hydrofracturing Enhancements	●	●	●	●	●	●	●	●	●	●	●	●	●	●	●	●	●	●	●	●
4.39 In-Well Air Stripping	●	●	●	●	●	●	●	●	●	●	●	●	●	●	●	●	●	●	●	●
4.40 Passive/Reactive Treatment Walls	●	●	●	●	●	●	●	●	●	●	●	●	●	●	●	●	●	●	●	●
3.11 Ex Situ Biological Treatment																				
4.41 Bioreactors	●	●	●	●	●	●	●	●	●	●	●	●	●	●	●	●	●	●	●	●
4.42 Constructed Wetlands	●	●	●	●	●	●	●	●	●	●	●	●	●	●	●	●	●	●	●	●
3.12 Ex Situ Physical/Chemical Treatment (assuming pumping)																				
4.43 Adsorption/Absorption	●	●	●	●	●	●	●	●	●	●	●	●	●	●	●	●	●	●	●	●
4.44 Advanced Oxidation Processes	●	●	●	●	●	●	●	●	●	●	●	●	●	●	●	●	●	●	●	●
4.45 Air Stripping	●	●	●	●	●	●	●	●	●	●	●	●	●	●	●	●	●	●	●	●
4.46 Granulated Activated Carbon/Liquid Phase Carbon Adsorption	●	●	●	●	●	●	●	●	●	●	●	●	●	●	●	●	●	●	●	●
4.47 Groundwater Pumping/Pump & Treat	●	●	●	●	●	●	●	●	●	●	●	●	●	●	●	●	●	●	●	●
4.48 Ion Exchange	●	●	●	●	●	●	●	●	●	●	●	●	●	●	●	●	●	●	●	●
4.49 Precipitation/Coagulation/Flocculation	●	●	●	●	●	●	●	●	●	●	●	●	●	●	●	●	●	●	●	●
4.50 Separation	●	●	●	●	●	●	●	●	●	●	●	●	●	●	●	●	●	●	●	●
4.51 Sprinkler Irrigation	●	●	●	●	●	●	●	●	●	●	●	●	●	●	●	●	●	●	●	●
3.13 Containment																				
4.52 Physical Barriers	●	●	●	●	●	●	●	●	●	●	●	●	●	●	●	●	●	●	●	●
4.53 Deep Well Injection	●	●	●	●	●	●	●	●	●	●	●	●	●	●	●	●	●	●	●	●
3.14 Air Emissions/Off-Gas Treatment																				
4.54 Biofiltration	●	N/A	●	●	◇	●	●	●	●	●	●	●	●	●	●	●	●	●	●	●
4.55 High Energy Destruction	○	N/A	I/D	I/D	○	●	I/D	●	●	●	●	●	●	●	●	●	●	●	●	●
4.56 Membrane Separation	○	N/A	I/D	I/D	○	●	I/D	●	●	●	●	●	●	●	●	●	●	●	●	●
4.57 Oxidation	●	N/A	●	●	●	●	I/D	●	●	●	●	●	●	●	●	●	●	●	●	●
4.58 Scrubbers	●	N/A	●	●	●	●	I/D	●	●	●	●	●	●	●	●	●	●	●	●	●
4.59 Vapor Phase Carbon Adsorption	●	N/A	●	●	●	●	I/D	●	●	●	●	●	●	●	●	●	●	●	●	●

TABLE 3-1: DEFINITION OF SYMBOLS USED IN THE TREATMENT TECHNOLOGIES SCREENING MATRIX

Factors	● Above Average	● Average	○ Below Average	Other
Development Status Scale status of an available technology	Implemented as part of the final remedy at multiple sites, well documented, understood, etc.	Has been implemented at full scale but still needs improvements, testing, etc.	Not been fully implemented but has been tested (pilot, bench, lab scale) and is promising	◇ Level of Effectiveness highly dependent upon specific contaminant and its application/design
Treatment Train Is the technology only effective as part of the treatment train?	Stand-alone technology (not complex in terms of number of media/treatment technologies, maybe one "routine" technology in addition)	Relatively simple (two-car train or so), and well understood, widely applied, etc.	Complex (more technologies, media to be treated, generates excessive waste, etc.)	
O&M Operation and Maintenance Intensive	Low degree of O&M intensity	Average degree of O&M intensity	High degree of O&M intensity	
Capital Capital Intensive	Low degree of capital investment	Average degree of capital investment	High degree of capital investment	
System Reliability / Maintainability The expected range of demonstrated reliability and maintenance relative to other effective technologies	High reliability and low maintenance	Average reliability and average maintenance	Low reliability and high maintenance	N/A "Not Applicable"
Relative overall cost and performance Relative Costs Design, construction, and operations and maintenance (O&M) costs of the core process that defines each and pre-and post-treatment	Low degree of general costs relative to other options	Average degree of general costs relative to other options	High degree of general costs relative to other options	I/D "Insufficient Data"
Time Time required to clean up a "standard" site using the technology	in situ soil Less than 1 year ex situ soil Less than 0.5 year groundwater Less than 3 years	1-3 years 0.5-1 year 3-10 years	More than 3 years for in situ soil More than 1 year for ex situ soil More than 10 years for water	
Availability Number of vendors that can design, construct, and maintain the technology	More than 4 vendors	2-4 vendors	Fewer than 2 vendors	
Contaminants Treated Contaminants are classified into eight groups: - Nonhalogenated VOCs - Halogenated VOCs - Nonhalogenated SVOCs - Halogenated SVOCs - Fuels - Inorganics - Radionuclides - Explosives	Effectiveness Demonstrated at Pilot or Full Scale	Limited Effectiveness Demonstrated at Pilot or Full Scale	No Demonstrated Effectiveness at Pilot or Full Scale	Same as above